

CORPORATE PROFILE

Hydraulic & Pneumatic Clamping Systems

(주)케이제이에프에 방문해 주신 것을 진심으로 환영합니다.
(주)케이제이에프는 자동화 공압/유압 클램프를 비롯해 로타리 조인트, 부스타, 워크서포트, 스윙블 패드, 플로우 컨트롤 밸브 및 토글클램프 등 워크홀딩 시스템에 필요한 다양한 제품을 전문적으로 생산하는 업체입니다.
부산소재 본사와 서울지사를 두고 있으며 언제나 고객과 함께 고객의 입장으로 제품을 제작하는데 최선을 다하고 있습니다. 한치 앞을 내다 볼 수 없는 무한 경쟁 세계에서 국내뿐만 아니라 해외시장으로 뻗어 나가기 위해 임직원 모두가 힘을 합쳐 일하고 있습니다.

1984년에 설립된 이래 30년이 넘는 시간 동안, 밀링 전용 픽스처, 용접 자동화 설비, 검사구, 조립 자동화 라인, 반도체 조립시설, 지그 & 픽스처, 가공 전용기 등에 들어가는 유압/공압 자동화 클램프 연구 개발에 앞장서서 치공구산업에 필수인 요소부품을 생산하기 위해 계속적으로 투자하고 있습니다.

표준화된 요소부품은 자동차, 지그, 통신기기, 광학기기, 섬유, 농업기계, 진공장비, 화학공업, 항공기기, 고무, 조선, 가정용전자기기, 중전기, 원동기, 중작업용 기기, 철도, 식품기계 등에 매우 중요한 부분입니다. 생산되는 제품의 전수 품질검사를 통해 불량률을 최소화 하고 있으며, 경쟁력 있는 가격 및 정밀도나 효율성에서 자사 제품이 최고라 자부합니다. 표준 클램프 제품 이외에, 고객의 작업 환경에 따라 요구되는 스페셜 사양에 대해서도 신속하고 정확한 솔루션(solution)을 제공하고 있습니다. 문제 해결에 대한 자문이 필요하시면 언제든지 연락바랍니다.

케이제이에프는 정성을 다해 전 제품 생산에 임하고 있으며 품질향상과 효율을 높이기 위해 불철주야 노력하고 있습니다. 애정과 관심으로 지켜봐 주시고 여러분의 성원에 보답하기 위해 최선을 다하겠습니다. 감사합니다.

KJF is a manufacturer specializing in products for work holding systems, including toggle clamps, hydraulic/pneumatic clamps, rotary joints, boosters, work supports, swivel pads and flow control valves etc.. Headquartered in Busan with a branch office in Seoul, we endeavor to create products manufactured from the customer's perspective. In the era of limitless competition, the KJF team is dedicated to expanding company operations into overseas markets.

Established in 1984, we have been leading the research and development of hydraulic/pneumatic automation clamps for milling fixture, welding automation facility, inspection jig, assembly automation line, semiconductor assembly facility, Jig & fixture, machining center etc. for more than 30 years, and we are investing continuously in manufacturing essential parts for the jig & fixture industry.

Standardized components are critical parts of the automotive, jig & fixture, telecommunication equipments, optic equipments, agriculture machines, vacuum equipments, chemical industry, aviation equipments, rubber, ship building, household electronic equipments, heavy electric equipments, motor, heavy duty equipments, railroad industry, grocery machines etc..

We minimize defect rate through quality inspection of products, and as a result we, are fully confident in our products in terms of precision, efficiency, and price. In addition to standard products, we also provide swift and accurate solutions for custom specifications. We are standing by to assist you with any inquiries and troubleshooting.

KJF is focused ceaselessly on improving product quality and efficiency. We will continue to exceed expectations on a solid foundation of your continued interest and support. Thank you.





Pin Hole Clamp

Page 7



Paraller Swing Clamp

제자리 스윙클램프

Page 29

**NEW
PRODUCTS**



Power Clamp

Page 41



Pneumatic Rorary Joint

Page 47

PNEUMATIC PRODUCTS

공압 제품들



PINHOLE CLAMP
> P7-10



BALL LOCK CLAMP
> P11-12



MULTI-LINK CLAMP
> P13-20



AUTO COUPLER
> P43-46



ROTARY JOINT
> P47-48



WORK SUPPORT
> P49-50



HYDRAULIC PRODUCTS

유압 제품들



ULTRAPRECISION LOCATOR
> P61-62



WORK SUPPORT
> P63-70



MULTI-LINK CLAMP
> P71-74



FLANGE CLAMP
> P151-154



THREADED BODY CLAMP
> P155-158



HOLLOW CLAMP
> P159



ROTARY JOINT
> P173-194



ROTARY DISTRIBUTORS VALVE
> P195-196



INTENSIFIER
> P197-198



OTHER PRODUCTS

기타 제품들



SWIVEL PAD
> P205-206



TUNGSTEN CARBIDE GRIPPER PAD
> P207-208

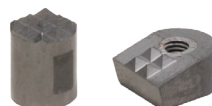

MOUNTING BASE
> P209



HINGE CLAMP
> P21-28



PARALLEL SWING(제자리스윙) CLAMP
> P29-32



SWING CLAMP
> P33-40



POWER CLAMP
> P41-42



ULTRAPRECISION(초정밀) LOCATOR
> P51-52



AIR SEATING VALVE
> P53-54



BOOSTER
> P55-56



2차전지대응제품(2nd. BATTERY)
> P57-58



HINGE(LINK) CLAMP
> P75-104



SWING CLAMP
> P105-128



BLOCK CLAMP
> P129-144



BUILT-IN CLAMP
> P145-150



EDGE CLAMP
> P160



ROCKER CLAMP
> P161-162



WISE CLAMP
> P163-166



AUTO COUPLER
> P167-172



SEQUENCE VALVE
> P199-200



FLOW CONTROL VALVE
> P201



DIRECTION VALVE
> P202



QUICK ACTION CLAMP
> P210



SEALING PLUG
> P211-212



CUSTOMIZED PRODUCTS
스페셜 제품들
> P213



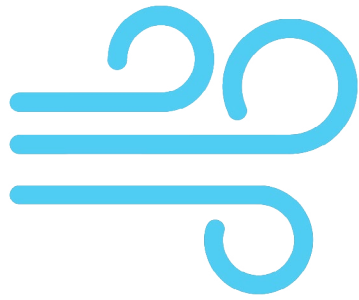

공압 제품들

Pneumatic Products



QR코드를 스캔하시면 작동영상을 보실 수 있습니다.
Please scan the QR code for watching operating animation.

Pin Hole Clamp Pneumatic Type

클램핑과 위치결정을 동시에!! Clamping and positioning at the same time!!



Operation

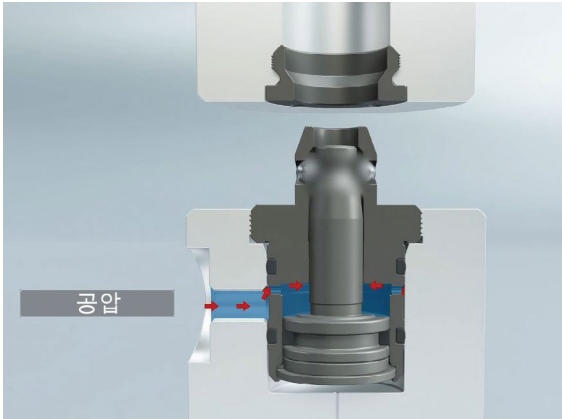

언클램핑: 공압에 의해 피스톤 하강. 볼이 들어감.
 Unclamping: Piston lowered by pneumatic pressure.
 The balls go in.

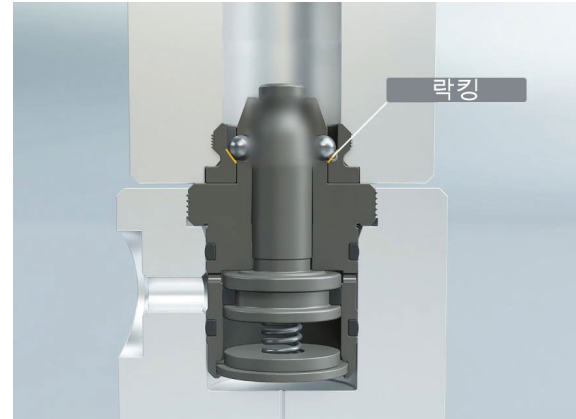

클램핑: 스프링력으로 피스톤 상승. 볼이 나옴.
 Clamping: Piston rises due to spring force.
 Balls come out.

Application



지그 교체 시 상판 고정 용도
 For fixing the top plate when replacing the jig



아래의 물체를 잡아 올리는 용도
 For lifting objects from below

Specification

Locking Force	Holding Force	Repeatability	Weight	Operating Pressure	Operating Temperature
10kgf	100kgf	0.1mm	40g	3 ~ 9.9 kgf/cm ²	0 ~ 70 °C

NEW



Pin Hole Clamp Thread Type

Features

- | | |
|-------------------------------------|--|
| 1. 클램핑과 위치결정 | 1. Clamping and positioning |
| 2. 컴팩트한 사이즈 | 2. Compact size |
| 3. 단동으로 작동 | 3. Operates in single-acting mode |
| 4. 외경: M22 | 4. Outer diameter: M22 |
| 5. 사용유체: 공압 | 5. Working fluid: Pneumatic |
| 6. 작동압력: 3.0~9.9kgf/cm ² | 6. Operating pressure: 3.0~9.9 kgf/cm ² |
| 7. 사용온도: 0~70°C | 7. Operating temperature: 0~70°C |

< PIN HOLE CLAMP PHC-0010 >

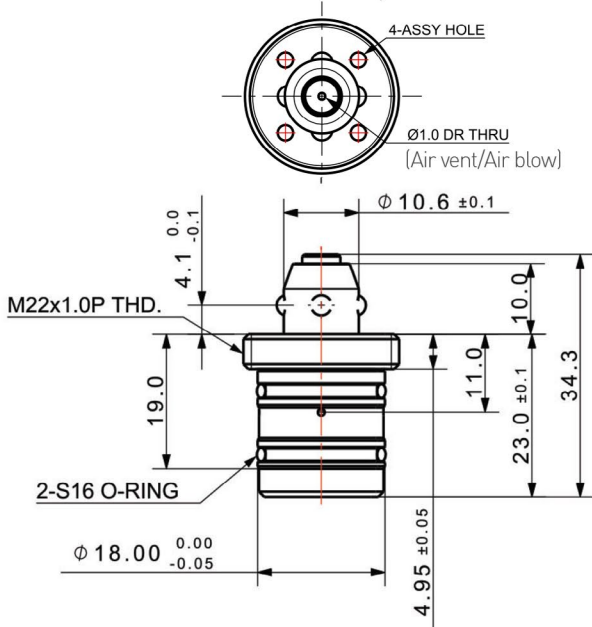

<PHS-0016>

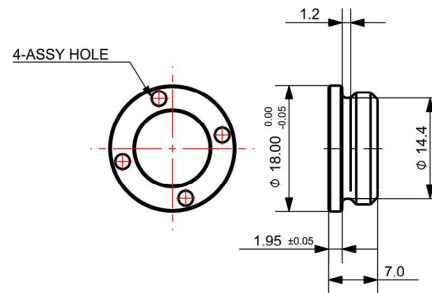

<MOUNTING HOLE>

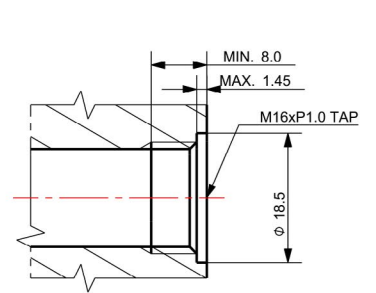

<MOUNTING HOLE>

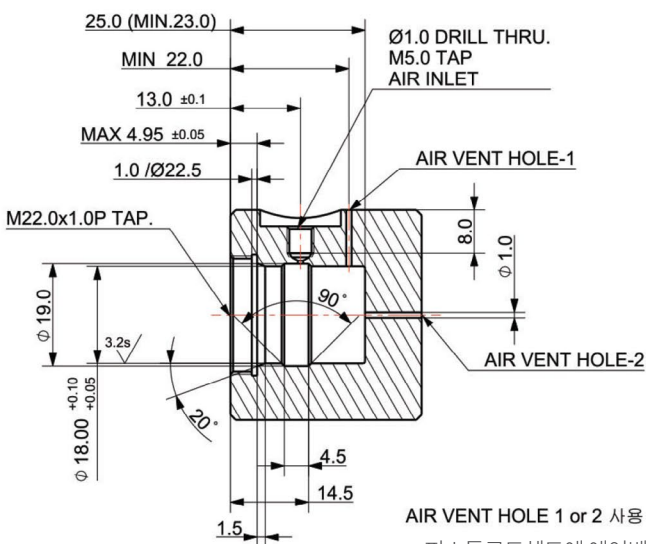

AIR VENT HOLE 1 or 2 사용

* 피스톤로드헤드에 에어벤트가 있는 경우는 가공할 필요 없음.

<ASSY>

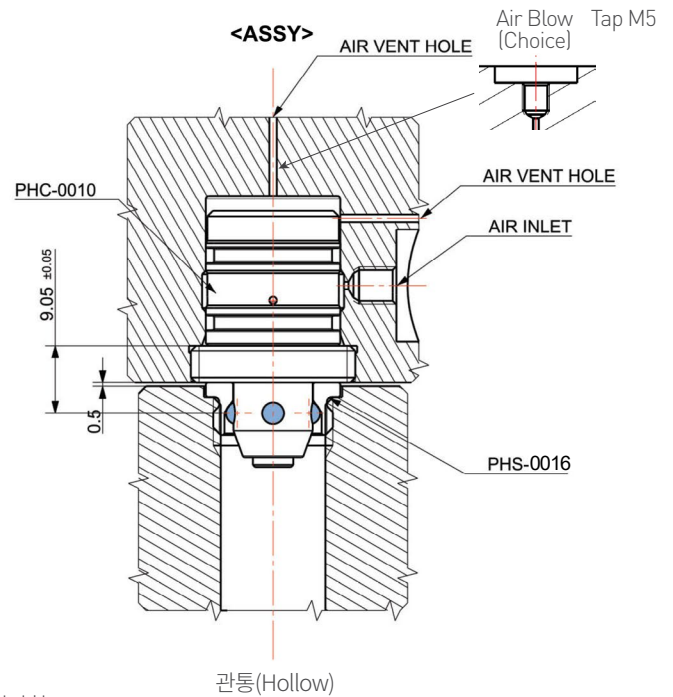

* 주의사항

- PHS-0016은 설치면 보다 제품이 돌출되게 설치되어야 함.
- PHC-0010은 설치면 보다 높거나 동일면에 설치되어야 함.

< COUNTER BALANCE SLEEVE PHS-2400 >

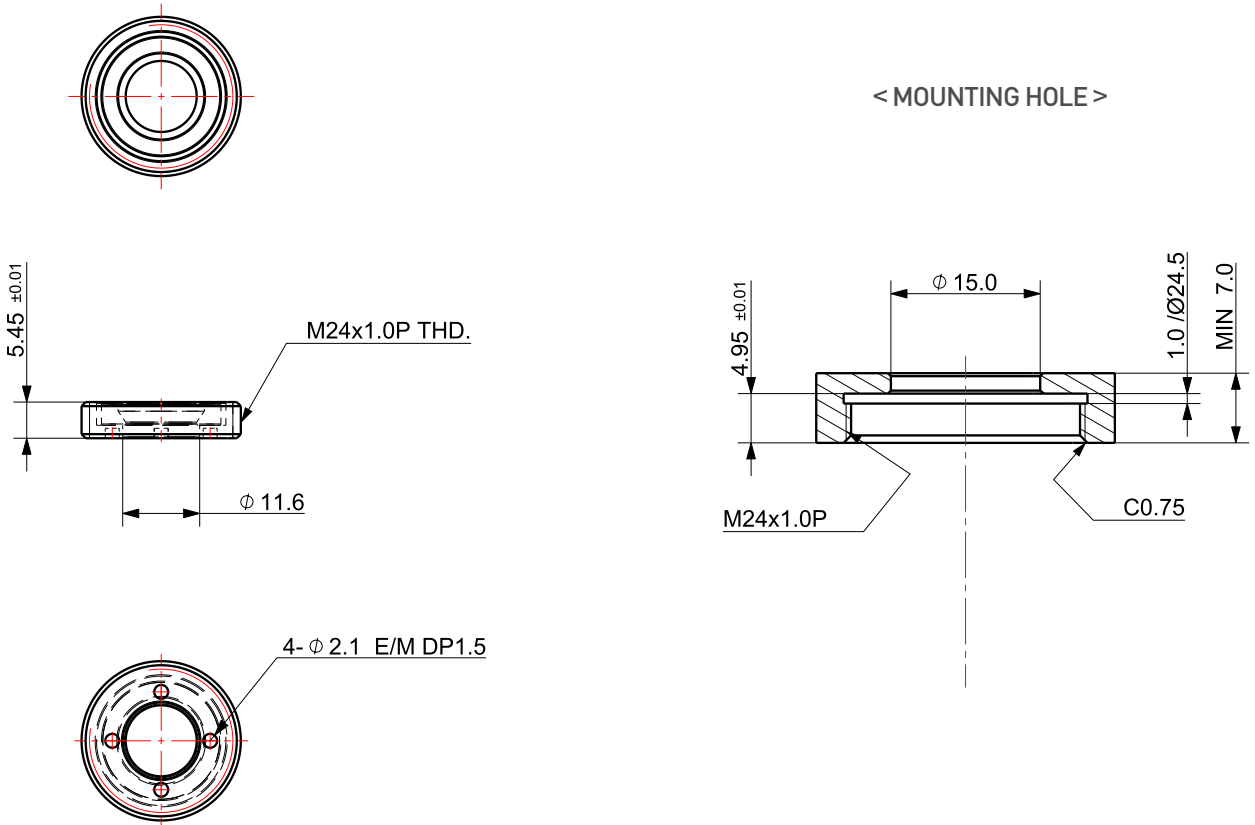

< ASSY TOOL ATL-0010 >

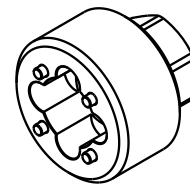
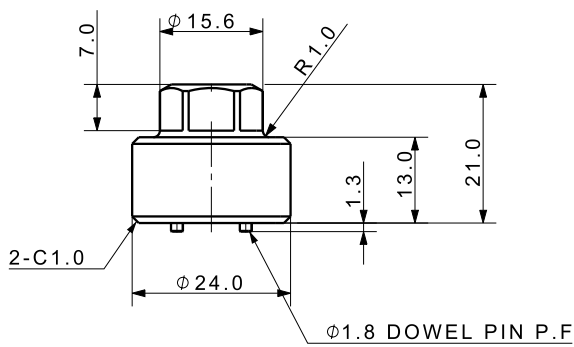

< SLEEVE ARRANGEMENT >

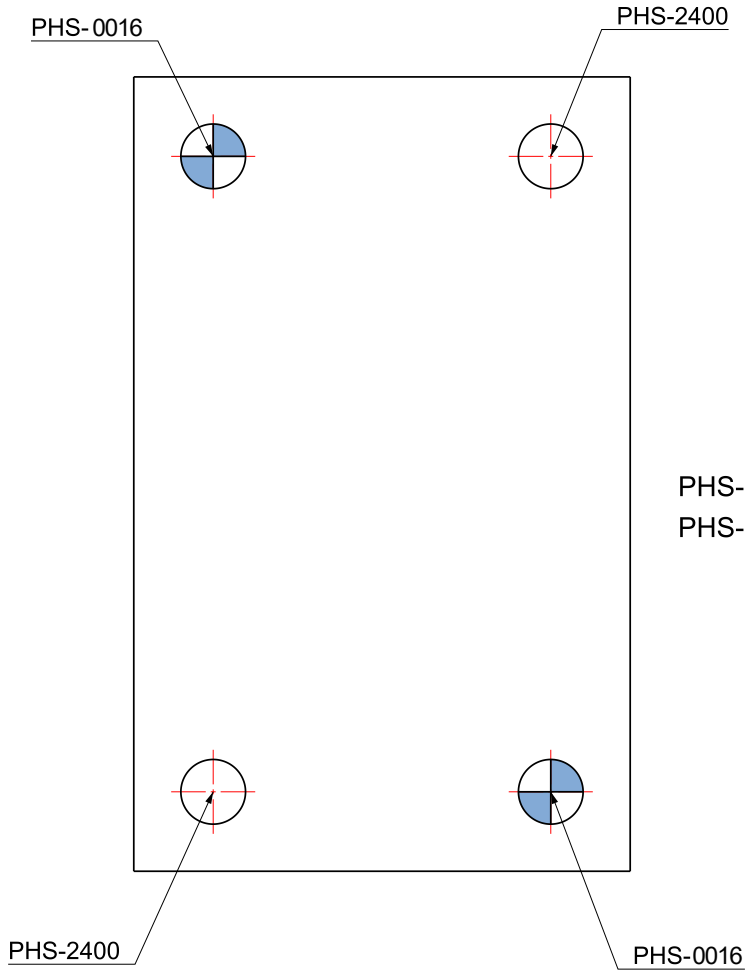

PHS-0016 : ZERO POINT CLAMPING SLEEVE
PHS-2400 : COUNTERBALANCE CLAMPING SLEEVE

위와 같이 4개의 핀홀클램프를 적용할 때는
PHS-0016 2개와 PHS-2400 2개를 함께 사용하십시오.

When applying 4 pinhole clamps as shown above,
please use 2 units of PHS-0016 and 2 units of PHS-2400 together.

Ball Lock Clamp



스프링 락 방식! Spring Lock Method!

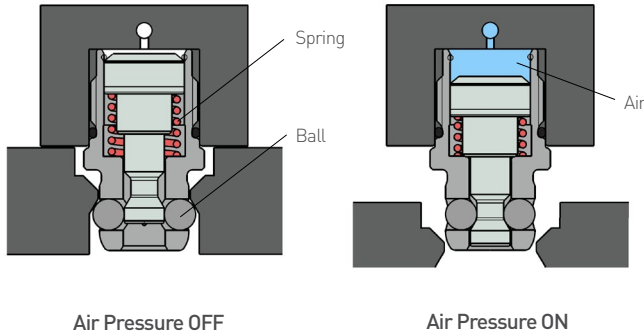

공압 OFF(잠김):
스프링에 의해 피스톤이 하강하고 볼들이 튀어나옵니다. 이 볼들이 파레트 표면과 접촉하여 고정됩니다.
공압 ON(풀림):
적은 양의 공압이 피스톤을 밀어올리고 볼들이 내부로 들어가게 됩니다.

Air Pressure OFF(LOCK):
The Piston is down by spring inside and the balls out to hold the pallet by contacting the surface of it.
Air Pressure ON(RELEASE):
The Piston is pushed by a little amount of air pressure and the balls are entered inside.

Application

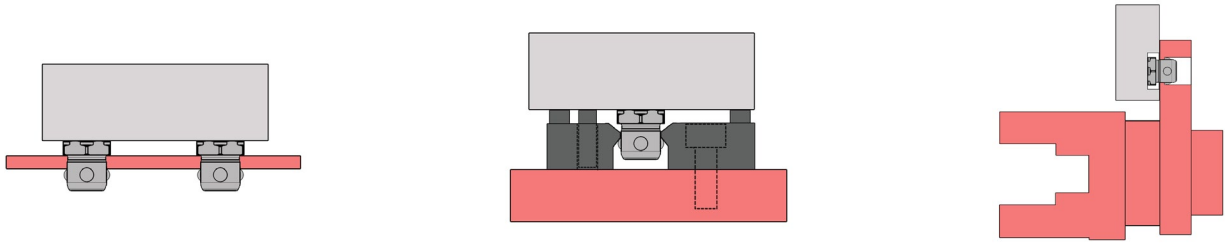

Model No.

BLC-0605□

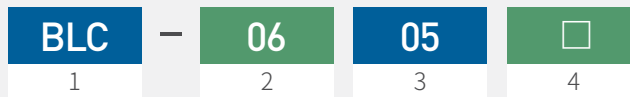

- 1** Clamp Type
BLC=Ball Lock Clamp
- 2** Pin External Diameter
ex) 08=8mm
- 3** Housing Diameter
ex) 05=5kgf
20=20kgf
- 4** Sort
No Sign = Pin
B = Bushing

Specification

MODEL NO.	BLC-0605	BLC-0807	BLC-1010	BLC-1215	BLC-1620	
Holding Force (kgf)	5	7	10	15	20	
Operating Pressure (kgf/cm ²)	2.5 - 7.1					
Operating Temperature (°C)	0 ~ 70					
Fluid	Air					
Release Air Capacity (cm ³)	0.08	0.08	0.15	0.26	0.49	
Weight (kg)	Pin	0.007	0.008	0.013	0.020	0.045
	Bushing	0.004	0.005	0.008	0.009	0.019

주의 : 이 제품을 칩과 냉각수가 있는 환경에서는 사용하지 마십시오.
지면과 평행한 방향으로 이동하여 락이될 경우, 가이드 핀을 함께 설치하십시오.

Caution : Do not use the product in the condition with chips and coolant.
In case of the product moves and locks in the direction pallelly with the ground,
please install the guide pin together.

Ball Lock Clamp

Features

- | | |
|-------------------------------------|---|
| 1. 강력한 락킹 | 1. Strong Locking |
| 2. 컴팩트한 사이즈 | 2. Compact Size |
| 3. 단동 | 3. Single-Action |
| 4. 외경범위: ø6.5~16 | 4. External Diameter: ø6.5~16 |
| 5. 사용유체: 공압 | 5. Fluid: Air |
| 6. 작동압력: 2.5~7.1kgf/cm ² | 6. Operating Pressure: 2.5~7.1kgf/cm ² |
| 7. 사용온도: 0~70°C | 7. Operating Temperature: 0~70°C |



> BLC-06 05 BLC-06 05 B

① ② ① ② ③

① External Diameter ② Holding Force(kgf) ③ Bushing

Dimensions

MODEL NO.	BLC-0605	BLC-0807	BLC-1010	BLC-1215	BLC-1620
A	ø6.5	ø8.0	ø10.0	ø12.0	ø16.0
B	19.5	20.5	22.5	25	29.5
C	7.0	8.0	9.0	10.0	11.5
D	ø9.0	ø9.0	ø10.7	ø12.7	ø16.1
E	4.0	4.5	5.0	5.5	6.5
F	10.6	10.6	11.1	12.1	14.1
G	3.0	3.0	3.0	3.0	3.4
H	M10x0.75P	M10x0.75P	M12x1.0P	M14x1.0P	M18x1.5P
J	SS8.5(NOK)	SS8.5(NOK)	SS10.5(NOK)	S12(NOK)	AS568-016
K	ø2.5	ø3.0	ø3.5	ø4.0	5.0
L	ø11.0	ø11.0	ø13.5	ø15.5	ø21.2
M	ø7.7	ø9.3	ø11.5	ø13.8	ø18.2
N	10.0	10.0	12.0	14.0	19.0
AA	ø14.0	ø14.0	ø18.0	ø20.0	ø26.0
AB	7.5	7.5	9.0	10.0	11.5
AC	2.0	2.0	2.5	2.5	3.0
AD	5.5	5.5	6.5	7.5	8.5
AE	ø6.7	ø8.2	ø10.2	ø12.2	ø16.2
AF	8.0	8.0	9.5	11.0	13.0
AG	ø12.0	ø12.0	ø15.0	ø17.0	ø23.0
AH	ø12.0	ø12.0	ø15.0	ø17.0	ø23.0
BA	ø10.4	ø10.4	ø12.4	ø14.4	ø19.4
BB	10.5	10.5	11.0	12.0	14.0
BC	7.5	7.5	8.0	9.0	10.5
BD	ø9.3	ø9.3	ø11.0	ø13.0	ø16.5
BE	2.4	2.4	2.4	2.8	3.8
BF	M10x0.75P	M10x0.75P	M12x1.0P	M14x1.0P	M18x1.5P
CA	ø7.9	ø9.5	ø11.8	ø14.2	ø18.6
CB	7.5	7.5	9.0	10	11.5
CC	ø6.7	ø8.2	ø10.2	ø12.2	16.2
CD	2.2	2.5	2.8	2.95	3.5
CE	0.4	0.4	0.8	0.7	1.0

< PIN >

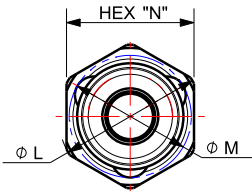

< BUSHING >

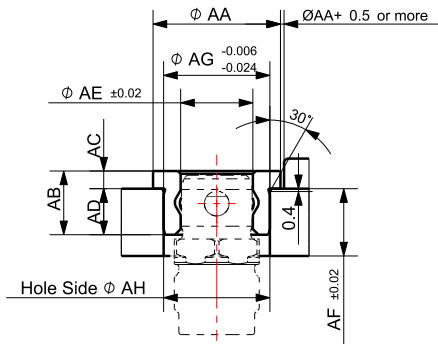

[HOW TO MOUNT THE BUSHING]

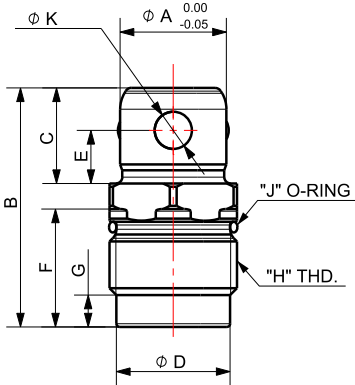
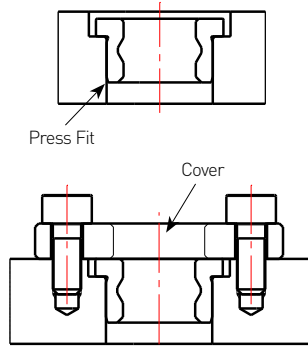

[MOUNTING HOLE MACHINING]

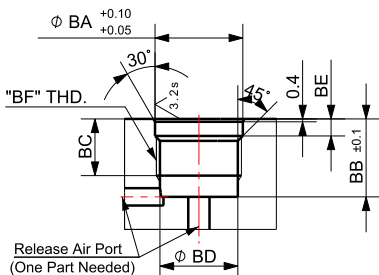

[WORKPIECE HOLE]

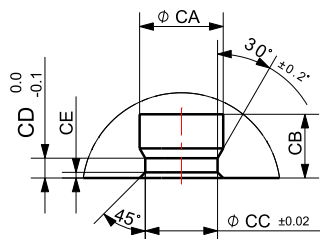

Multi-Link Clamp Pneumatic Magnetic Sensor

간섭을 피해 클램핑!! Clamping to avoid interference!!



작동 영상

Application

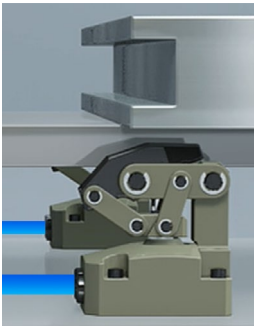

언클램프 상태
(상부 간섭 회피)

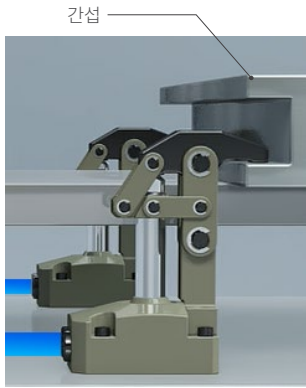

클램프 상태
(간섭 피해 클램프)

Piping Method

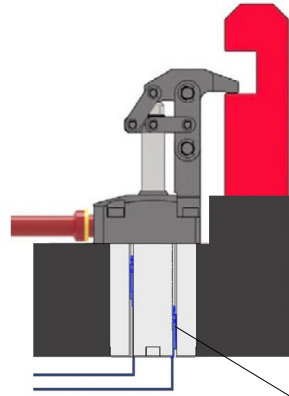

* 센서는 옵션입니다.
The Sensor is an option.
추천: YPC D-A94K

Sensor

* 하우징이 마운팅 되는 부분의 소재가 스텔일 경우
센서 감지에 문제가 발생될 수 있음. 알루미늄, 스테인레스 추천.

Model No.

MLC-2547AE

MLC	-	25	47	AE
1		2	3	4

1 Clamp Type
MLC = Multi-Link Clamp

2 Piston Diameter
ex) 25 = ø25

3 Housing Diameter
ex) 47 = ø47

4 Type
> A = Air(Pneumatic)
> E = Sensing

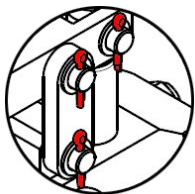

* 분할 핀 사양
Split pin

분할핀 사양은 주문제작으로 가능합니다.
The specifications of the split pin can be custom-made.

Multi-Link Clamp Magnetic Sensor Type



Features

- | | |
|---------------------------------------|---|
| 1. 간섭을 피해 클램프 | 1. Clamping to avoid interference |
| 2. 공압으로 작동/복동 | 2. Operating with pneumatic system |
| 3. 가스연질화 표면처리 | 3. Gas Nitriding Surface/Double-acting |
| 4. 내경범위: ø20~50 | 4. Piston Diameter: ø20~50 |
| 5. 작동압력: 3~9.9(공압)kgf/cm ² | 5. Operating Pressure:
3~9.9(Air)kgf/cm ² |
| 6. 사용온도: 0~60°C | 6. Operating Temperature: 0~60°C |
| 7. 레버는 옵션 | 7. Lever is option item |

> MLC-25 47 AE

① ② ③

- ① Piston Diameter(mm) ② Housing Diameter(mm)
③ Pneumatic Magnetic Sensor Type

*마그네트 비내장형도 가능. Non-magnetic Type is available.

Specification

Model No.	Clamping Force(kgf)	Piston Diameter(Ø)	Effective Area(cm ²)	Stroke(mm)			Operating Pressure Range (kgf/cm ²)	Operating Temperature Range(°C)	Weight(kg)
	5kgf/cm ²			Total	Clamp	Extra			
MLC-2038AE	13	20	3.14	27.5	25.0	2.5	3~9.99	0~60	0.64
MLC-2547AE	20	25	4.9	34.0	31.5	2.5			1.51
MLC-3255AE	31	32	8.04	38.0	35.5	2.5			2.22
MLC-4065AE	49	40	12.56	44.0	41.0	3.0			3.68
MLC-5080AE	79	50	19.63	50.0	47.0	3.0			5.86
MLC-6395AE	136	63	31.17	53.5	50.0	3.5			7.10

Clamping Force Calculation Formula

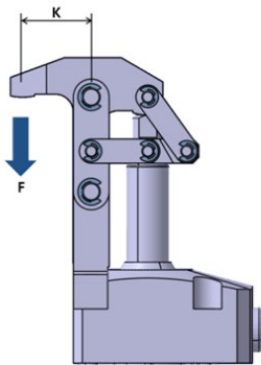

Pneumatic Clamp

클램핑력은 치수 K와 사용압력에 따라 변합니다. 아래의 계산식을 통해 클램핑력을 구해 주십시오.

Clamping force varies depending on dimension K and operating pressure. Use below formula to calculate clamping force.

- > F = Clamping Force(kgf)
- > P = Pneumatic Pressure(kgf/cm²)
- > K = 옆의 도면 참조 Refer to Drawing (mm)

PNEUMATIC

- MLC-2038AE : F = 54.9 x P/K
- MLC-2547AE : F = 93.1 x P/K
- MLC-3255AE : F = 172.0 x P/K
- MLC-4065AE : F = 306.2 x P/K
- MLC-5080AE : F = 588.0 x P/K
- MLC-6395AE : F = 1090.9 x P/K

* K 치수: 카탈로그 치수의 30% 이상 커지는 것은 권장 안함.
K Dimension: It is not recommended to exceed 30% of the catalog dimension.

Drawing

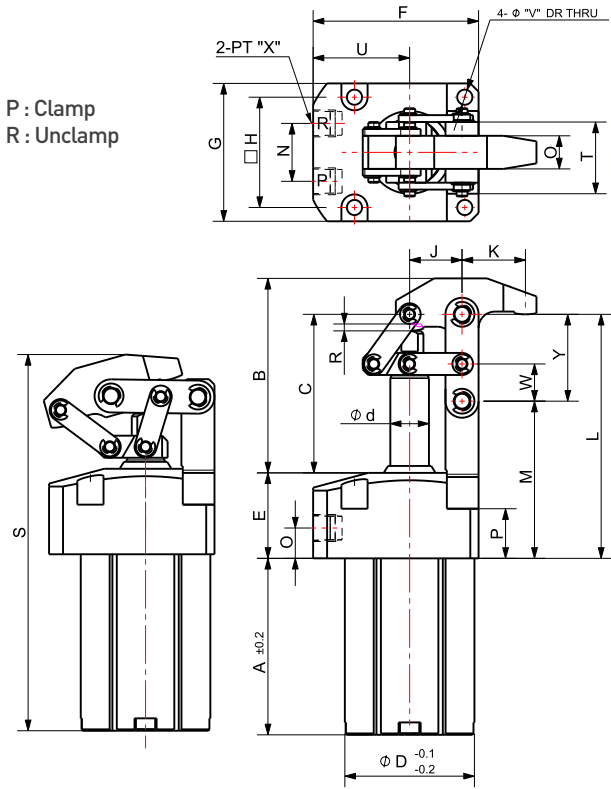

Dimensions

MODEL NO.	MLC-2038AE	MLC-2547AE	MLC-3255AE	MLC-4065AE	MLC-5080AE	MLC-6395AE
A	53.0	64.0	75.0	84.0	91.0	101.5
B	59.5	70.5	79.5	98.0	111.0	121.0
C	46.5	57.5	64.5	80.0	89.0	97.5
D	38.0	47.0	55.0	65.0	80.0	95.0
d	10.0	14.0	14.0	16.0	20.0	25.0
E	25.0	31.0	31.0	38.0	44.0	45.0
F	51.0	60.0	67.0	80.0	93.0	113.0
G	41.0	50.0	59.0	69.0	84.0	98.0
H	33.0	40.0	47.0	55.0	67.0	80.0
J	17.5	19.0	21.5	24.5	30.0	35.0
K	21.5	23.0	28.0	31.0	37.0	43.5
L	71.5	88.5	95.5	118.0	133.0	138.0
M	45.5	57.0	60.5	72.5	83.0	88.0
N	18.0	21.0	21.0	25.0	28.0	36.0
O	10.0	11.0	11.5	14.0	16.0	16.0
P	15.0	18.0	17.0	21.0	23.0	25.0
Q	10.0	12.0	16.0	19.0	22.0	26.0
R	2.5	2.5	2.5	3.0	3.0	3.5
S	115.0	136.4	154.1	176.4	198.5	222.9
T	19.0	22.0	28.0	36.0	42.0	48.0
U	28.0	35.0	37.5	45.5	51.0	64.0
V	4.5	5.5	6.6	9.0	11.0	11.0
W	10.0	13.5	15.0	17.5	19.0	19.0
X	PT1/8	PT1/8	PT1/8	PT1/4	PT1/4	PT1/4
Y	26.0	31.5	35.0	45.5	50.0	55.0

Clampable Dimension for Interference Part

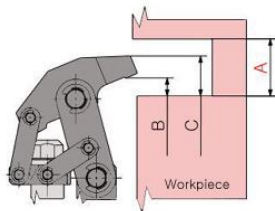

* A: minimum dimension

Model NO.	MLC-2038	MLC-2547	MLC-3255	MLC-4065	MLC-5080	MLC-6395AE
A	18	20	25	29	35	44
B	5.4	6.34	8.61	9.29	11.1	13.3
C	14	15	17.9	20	24.5	31.0
stroke @ "C"	15	20	22	26	30	34.5

LEVER (OPTION)

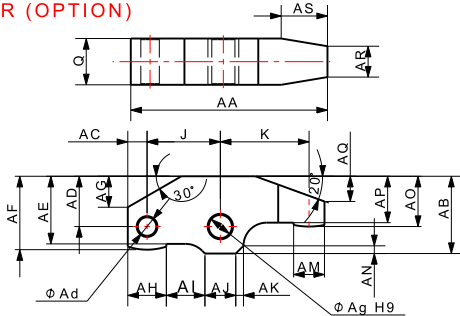

Dimensions

MODEL NO.	MLC-2038AE	MLC-2547AE	MLC-3255AE	MLC-4065AE	MLC-5080AE	MLC-6395AE
AA	47.5	51.0	59.0	66.5	78.0	95.0
AB	20.0	20.0	23.0	28.0	34.0	37.0
AC	4.5	5.0	5.5	7.0	7.0	8.3
AD	13.0	13.0	15.0	18.0	22.0	23.0
øAd	4.8	4.8	5.8	6.8	6.8	8.5
øAg	5.0	6.0	8.0	10.0	12.0	15.0
AE	17.5	17.5	19.5	24.5	29.0	29.3
AF	19.0	19.0	21.0	26.0	32.0	36.5
AG	8.0	8.0	10.0	14.0	16.0	14.4
AH	11.0	10.0	11.0	14.0	14.0	16.5
AI	7.0	10.0	11.0	12.5	16.0	20.9
AJ	8.0	8.0	8.0	10.0	12.0	12.1
AK	2.0	2.0	5.0	5.0	7.0	7.8
AM	8.0	8.0	8.0	8.0	8.0	10.0
AN	2.0	2.0	3.0	5.0	5.0	6.5
AO	13.0	13.0	15.0	18.0	22.0	28.2
AP	12.0	12.0	14.0	17.0	21.0	26.0
AQ	6.5	6.5	8.0	9.5	10.6	10.9
AR	6.0	8.0	12.0	14.0	16.0	18.5
AS	12.0	12.0	16.0	17.0	20.0	25.0

Mounting Detail

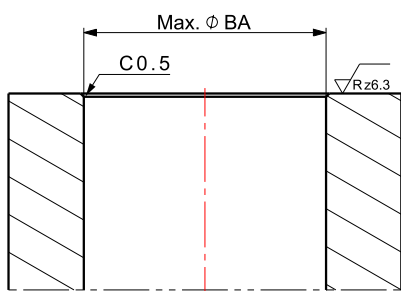
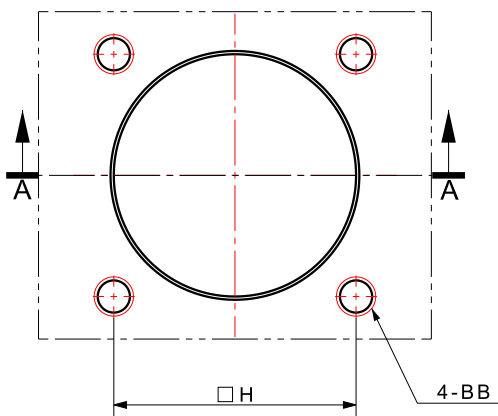

Section view A-A (1:1)

Dimensions

MODEL NO.	H	øBA	BB
MLC-2038AE	33.0	39.0	M4
MLC-2547AE	40.0	48.0	M5
MLC-3255AE	47.0	56.0	M6
MLC-4065AE	55.0	66.0	M8
MLC-5080AE	67.0	81.0	M10
MLC-6395AE	80.0	96.0	M10

Multi-Link Clamp Pneumatic Clamp

간섭을 피해 클램핑!! Clamping to avoid interference!!



작동 영상

Application

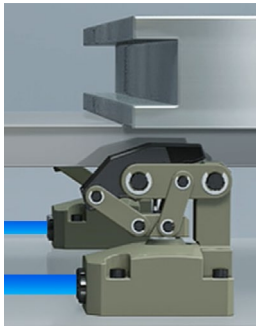

언클램프 상태
(상부 간섭 회피)

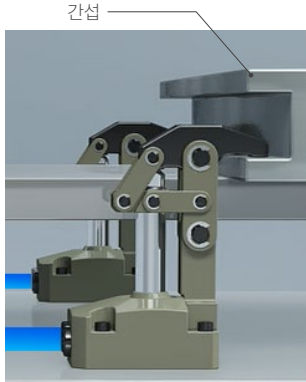

클램프 상태
(간섭 피해 클램프)

Piping Method

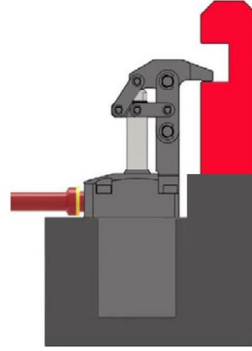

* 매니폴더 배관방식(주문제작)
Manifold Piping Method
(Customized Design)

Operation



Model No.

MLC-2547A

MLC	-	25	47	A
1		2	3	4

1 Clamp Type
MLC = Multi-Link Clamp

2 Piston Diameter
ex) 25 = ø25

3 Housing Diameter
ex) 47 = ø47

4 Type
> A = Air(Pneumatic)

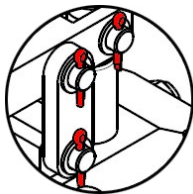

* 분할 핀 사양
Split pin

분할핀 사양은 주문제작으로 가능합니다.
The specifications of the split pin can be custom-made.

Multi-Link Clamp Standard Type



Features

- | | |
|---------------------------------------|---|
| 1. 간섭을 피해 클램프 | 1. Clamping to avoid interference |
| 2. 공압으로 작동/복동 | 2. Operating with pneumatic system |
| 3. 가스연질화 표면처리 | 3. Gas Nitriding Surface/Double-acting |
| 4. 내경범위: ø20~50 | 4. Piston Diameter: ø20~50 |
| 5. 작동압력: 3~9.9(공압)kgf/cm ² | 5. Operating Pressure:
3~9.9(Air)kgf/cm ² |
| 6. 사용온도: 0~60°C | 6. Operating Temperature: 0~60°C |
| 7. 레버는 옵션 | 7. Lever is option item |

> MLC-2547A

① ② ③

① Piston Diameter(mm) ② Housing Diameter(mm)

③ Air Type

Specification

Model No.	Clamping Force(kgf)	Piston Diameter(Ø)	Effective Area(cm ²)	Stroke(mm)			Operating Pressure Range (kgf/cm ²)	Operating Temperature Range(°C)	Weight(kg)
	5kgf/cm ²			Total	Clamp	Extra			
MLC-2038A	13	20	3.14	27.5	25.0	2.5	3~9.99	0~60	0.64
MLC-2547A	20	25	4.9	34.0	31.5	2.5			1.51
MLC-3255A	31	32	8.04	38.0	35.5	2.5			2.22
MLC-4065A	49	40	12.56	44.0	41.0	3.0			3.68
MLC-5080A	79	50	19.63	50.0	47.0	3.0			5.86

Clamping Force Calculation Formula

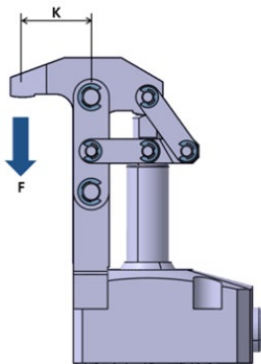

Pneumatic Clamp

클램핑력은 치수 K와 사용압력에 따라 변합니다. 아래의 계산식을 통해 클램핑력을 구해 주십시오.

Clamping force varies depending on dimension K and operating pressure. Use below formula to calculate clamping force.

- > F = Clamping Force(kgf)
- > P = Pneumatic Pressure(kgf/cm²)
- > K = 옆의 도면 참조 Refer to Drawing (mm)

PNEUMATIC

- MLC-2038A : F = 54.9 x P/K
- MLC-2547A : F = 93.1 x P/K
- MLC-3255A : F = 172.0 x P/K
- MLC-4065A : F = 306.2 x P/K
- MLC-5080A : F = 588.0 x P/K

* K 치수: 카탈로그 치수의 30% 이상 커지는 것은 권장 안함.
K Dimension: It is not recommended to exceed 30% of the catalog dimension.

Drawing

* 몸체색상은 임의로 변경될 수도 있습니다.

* Body color would be randomly changed.

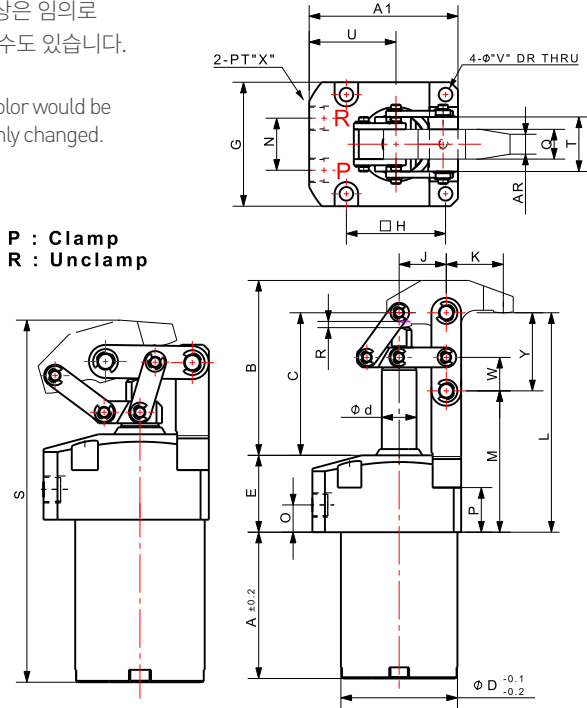

Dimensions

MODEL NO.	MLC-2038A	MLC-2547A	MLC-3255A	MLC-4065A	MLC-5080A
A	48.0	59.0	70.0	79.0	86.0
A1	51.0	60.0	67.0	80.0	93.0
B	59.5	70.5	79.5	98.0	111.0
C	46.5	57.5	64.5	80.0	89.0
φD	38.0	47.0	55.0	65.0	80.0
φd	10.0	14.0	14.0	16.0	20.0
E	25.0	31.0	31.0	38.0	44.0
F	22.5	29.0	32.0	37.0	44.0
G	41.0	50.0	59.0	69.0	84.0
H	33.0	40.0	47.0	55.0	67.0
J	17.5	19.0	21.5	24.5	30.0
K	21.5	23.0	28.0	31.0	37.0
L	71.5	88.5	95.5	118.0	133.0
M	45.5	57.0	60.5	72.5	83.0
N	18.0	21.0	21.0	25.0	28.0
O	10	11.0	11.5	14.0	16.0
P	15.0	18.0	17.0	21	23.0
Q	10.0	12.0	16.0	19.0	22.0
R	2.5	2.5	2.5	3.0	3.0
S	107.5	131.4	148.2	171.4	193.5
T	19.0	22.0	28.0	36.0	42.0
U	28.0	35.0	37.5	45.5	51.0
V	4.5	5.5	6.6	9.0	11.0
W	10.0	13.5	15.0	17.5	19.0
X	PT1/8	PT1/8	PT1/8	PT1/4	PT1/4
Y	26.0	31.5	35.0	45.5	50

Clampable Dimension for Interference Part

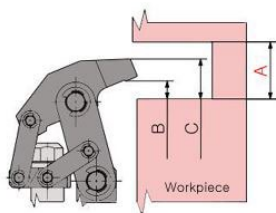

* A: minimum dimension

Model NO.	MLC-2038	MLC-2547	MLC-3255	MLC-4065	MLC-5080
A	18	20	25	29	35
B	5.4	6.34	8.61	9.29	11.1
C	14	15	17.9	20	24.5
stroke @ "C"	15	20	22	26	30

LEVER (OPTION)

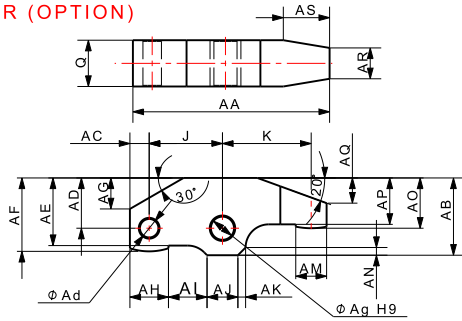

Dimensions

MODEL NO.	MLC-2038A	MLC-2547A	MLC-3255A	MLC-4065A	MLC-5080A
AA	47.5	51.0	59.0	66.5	78.0
AB	20.0	20.0	23.0	28.0	34.0
AC	4.5	5.0	5.5	7.0	7.0
AD	13.0	13.0	15.0	18.0	22.0
ϕAd	4.8	4.8	5.8	6.8	6.8
ϕAg	5.0	6.0	8.0	10.0	12.0
AE	17.5	17.5	19.5	24.5	29.0
AF	19.0	19.0	21.0	26.0	32.0
AG	8.0	8.0	10.0	14.0	16.0
AH	11.0	10.0	11.0	14.0	14.0
AI	7.0	10.0	11.0	12.5	16.0
AJ	8.0	8.0	8.0	10.0	12.0
AK	2.0	2.0	5.0	5.0	7.0
AM	8.0	8.0	8.0	8.0	8.0
AN	2.0	2.0	3.0	5.0	5.0
AO	13.0	13.0	15.0	18.0	22.0
AP	12.0	12.0	14.0	17.0	21.0
AQ	6.5	6.5	8.0	9.5	10.6
AR	6.0	8.0	12.0	14.0	16.0
AS	12.0	12.0	16.0	17.0	20.0

Mounting Detail

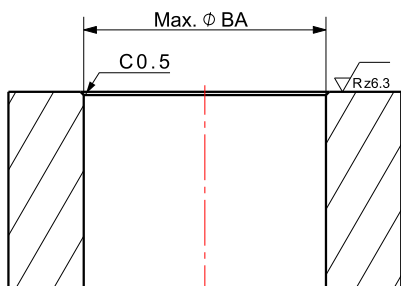
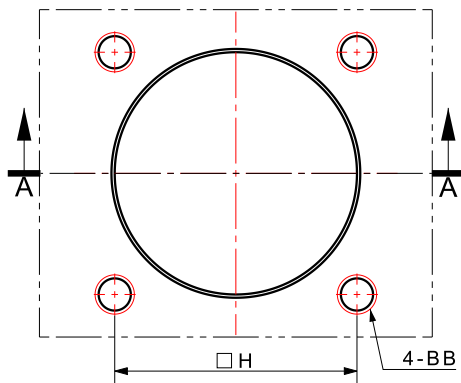

Section view A-A (1:1)

Dimensions

MODEL NO.	H	ϕBA	BB
MLC-2038A	33	39	M4
MLC-2547A	40.0	48.0	M5
MLC-3255A	47.0	56.0	M6
MLC-4065A	55.0	66.0	M8
MLC-5080A	67.0	81.0	M10

Hinge(Link) Clamp Pneumatic Magnetic Sensor

Application

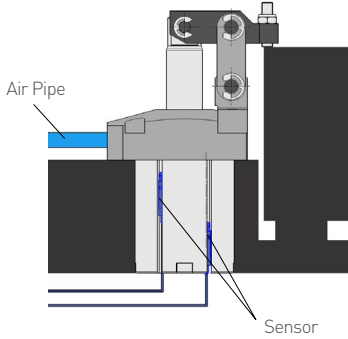

* 매니폴더 배관방식(주문제작)
Manifold Piping Method
(Customized Design)



* 센서는 옵션입니다.
The Sensor is an option.
추천: YPC D-A94K

* 하우징이 마운팅 되는 부분의 소재가 스텔일 경우
센서 감지에 문제가 발생될 수 있음. 알루미늄, 스테인레스 추천.

Model No.

HGC-2547AE

HGC	-	25	47	AE
1		2	3	4

1 Clamp Type
HGC = Hinge Clamp

2 Piston Diameter
ex) 25 = $\phi 25$

3 Housing Diameter
ex) 47 = $\phi 47$

4 Type
> A = Pneumatic (Air)
> E = Sensing

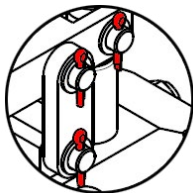

* 분할 핀 사양
Split pin

분할핀 사양은 주문제작으로 가능합니다.
The specifications of the split pin can be custom-made.

Hinge(Link) Clamp Magnetic Sensor Type



*마그네트 비내장형도 가능. Non-magnetic Type is available.

Features

1. 마그네트 내장형
 2. 클램핑/언클램핑 센싱
 3. 복동으로 작동
 4. 내경범위 : $\phi 20\sim 50$
 5. 작동압력 : $3\sim 9.9\text{kgf/cm}^2$
 6. 사용온도 : $0\sim 60^\circ\text{C}$
 7. 피스톤 속도 : $8\sim 100\text{mm/s}$
 8. 레버는 옵션
1. Built-in magnet type
 2. Sensing for clamping/unclamping
 3. Double-acting
 4. Piston Diameter : $\phi 20\sim 50$
 5. Operating Pressure : $3\sim 9.9\text{kgf/cm}^2$
 6. Operating Temperature : $0\sim 60^\circ\text{C}$
 7. Piston Speed : $8\sim 100\text{mm/s}$
 8. Lever is option item

> HGC - 20 36 AE

① ② ③

① Piston Diameter ② Housing Diameter ③ Pneumatic Magnetic Sensor Type

Specification

Model No.	Clamping Force(kgf)	Piston Diameter(ϕ)	Effective Area(cm^2)	Stroke(mm)			Operating Pressure Range (kgf/cm^2)	Operating Temperature Range($^\circ\text{C}$)	Weight(kg)
	5 kgf/cm^2			Total	Clamp	Extra			
HGC-2036AE	12	20	3.14	18.5	16.0	2.5	3~9.99	0~60	0.60
HGC-2547AE	31	25	4.9	24.0	21.5	2.5			1.51
HGC-3255AE	52	32	8.04	28.0	25.5	2.5			2.27
HGC-4065AE	78	40	12.56	33.0	30.0	3.0			3.41
HGC-5080AE	125	50	19.63	39.0	36.0	3.0			5.78
HGC-6395AE	200	63	31.17	50.0	47.0	3.0			7.10

Clamping Force Calculation Formula

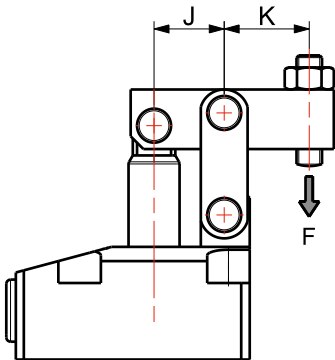

Pneumatic Clamp

클램핑력은 치수 K와 사용압력에 따라 변합니다. 아래의 계산식을 통해 클램핑력을 구해 주십시오.

Clamping force varies depending on dimension K and operating pressure.
Use below formula to calculate clamping force.

- > F = Clamping Force(kgf)
- > P = Pneumatic Pressure(kgf/cm^2)
- > K = 도면 참조 Refer to Drawing (mm)

PNEUMATIC

- HGC-2036AE : $F = 45.5 \times P / K$
- HGC-2547AE : $F = 107.9 \times P / K$
- HGC-3255AE : $F = 208.9 \times P / K$
- HGC-4065AE : $F = 389.4 \times P / K$
- HGC-5080AE : $F = 726.1 \times P / K$
- HGC-6395AE : $F = 1402.7 \times P / K$

* K 치수: 카탈로그 치수의 30% 이상 커지는 것은 권장 안함.
K Dimension: It is not recommended to exceed 30% of the catalog dimension.

Drawing

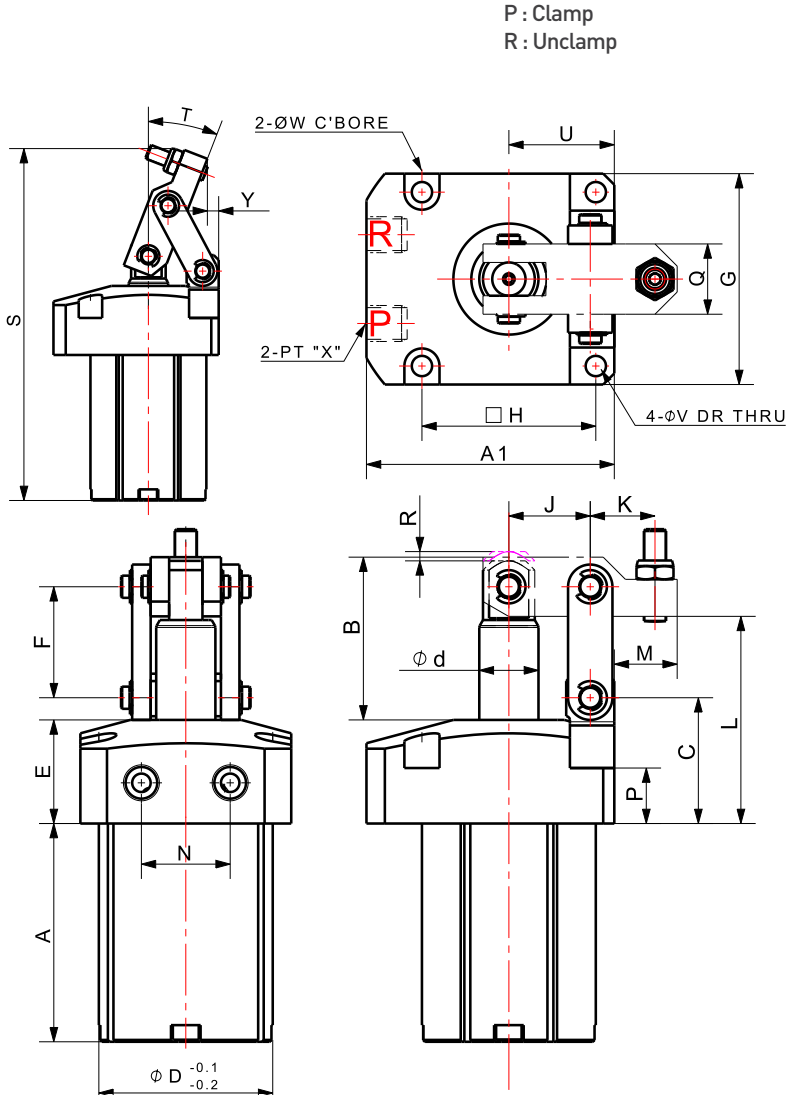

Dimensions

MODEL NO.	HGC-2036AE	HGC-2547AE	HGC-3255AE	HGC-4065AE	HGC-5080AE	HGC-6395AE
A	41.0	59.0	63.0	72.0	85.0	97.0
A1	49.0	67.0	78.0	91.0	108.0	129.0
B	30.5	44.0	55.0	64.0	76.0	92.0
C	28.0	34.0	41.0	42	49.0	54.0
D	36.0	47.0	55.0	65.0	80.0	95.0
d	10.0	16.0	20.0	25.0	32.0	40.0
E	23.0	28.0	28.0	30.0	35.0	36.0
F	20.0	30.0	33.0	41.0	48.0	56.0
G	40.0	57.0	70.0	78.0	88.0	106.0
H	31.5	47.0	55.0	63.0	70.0	85.0
J	14.5	22.0	26.0	31.0	37.0	45.0
K	19.0	17.5	20.0	25.0	29.0	35.0
L	41.0	56.0	65.0	72.0	83.0	92.0
M	18.5	17.0	17.0	22.0	26.0	30.0
N	16.0	24.0	30.0	33.0	35.0	40.0
P	14.0	15.0	15.0	15.0	18.0	18.0
Q	10.0	19.0	22.0	26.0	30.0	38.0
R	2.5	2.5	2.5	3.0	3.0	3.0
S	105.3	142.7	158.4	182.3	213.9	244.0
T	19.6°	21.2°	23°	23.3°	24.2°	25.3
U	20.0	28.5	35.0	42.0	50.0	62.0
V	4.5	5.5	6.6	9.0	11.0	13.0
W	7.5	9.5	11.0	14.0	18.0	20.0
X	PT1/8	PT1/8	PT1/8	PT1/4	PT1/4	PT1/4
Y	2.9	4.6	6.4	6.6	6.1	6.5

LEVER (OPTION)

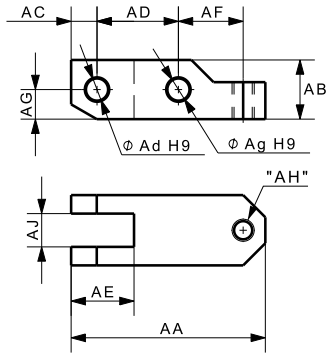

Dimensions

MODEL NO.	HGC-2036AE	HGC-2547AE	HGC-3255AE	HGC-4065AE	HGC-5080AE	HGC-6395AE
AA	43.0	52.5	60.0	72.0	86.0	104.0
AB	12.5	16.0	18.0	22.0	28.0	36.0
AC	4.5	7.0	8.0	8.0	10.0	12.0
AD	14.5	22.0	26.0	31.0	37.0	45.0
AE	10.0	17.0	19.5	23.0	28.0	36.0
AF	19.0	17.5	20.0	25.0	29.0	35.0
AG	4.5	8.0	9.0	11.0	14.0	18.0
AH	M5	M6	M6	M8	M10	M10
AJ	5.0	9.0	11.0	11.0	13.0	17.0
Ad	5.0	$\phi 6.0$	$\phi 6.0$	$\phi 8.0$	$\phi 10.0$	$\phi 12.0$
Ag	5.0	$\phi 6.0$	$\phi 8.0$	$\phi 10.0$	$\phi 12.0$	$\phi 16.0$

Mounting Detail

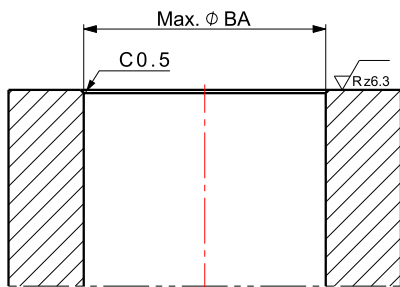
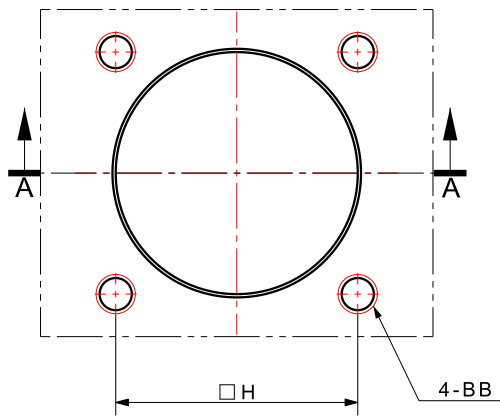

Section view A-A (1:1)

Dimensions

MODEL NO.	H	ϕBA	BB
HGC-2036AE	31.5	37.0	M4
HGC-2547AE	47.0	48.0	M5
HGC-3255AE	55.0	56.0	M6
HGC-4065AE	63.0	66.0	M8
HGC-5080AE	70.0	81.0	M10
HGC-6395AE	85.0	96.0	M12

Hinge(Link) Clamp Pneumatic Clamp

Piping Method

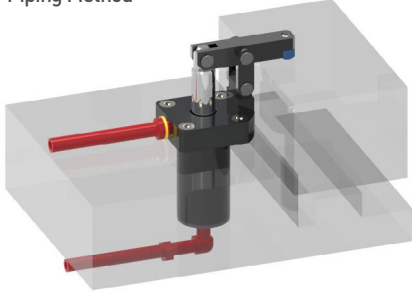

Special Types for Sensing (주문제작품)

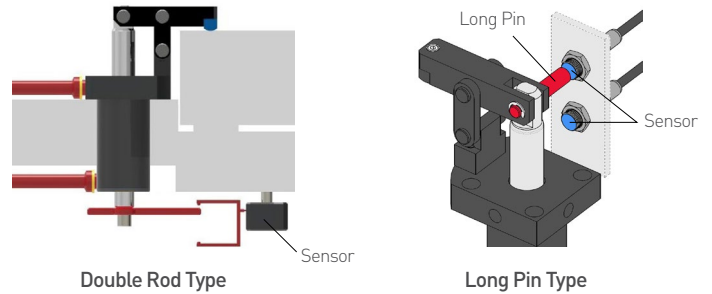

Model No.

HGC-1519A

HGC	-	15	19	A	M
1		2	3	4	5

1 Clamp Type
HGC = HINGE CLAMP

2 Piston Diameter
ex) 15 = $\phi 15$

3 Piston Rod Stroke
ex) 19 = 19mm

4 Type
> A = Pneumatic (Air)

5 주문제작 Type
M = Long Pin Type
D = Double Rod Type

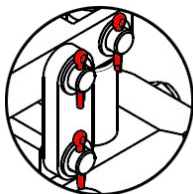

* 분할 핀 사양
Split pin

분할핀 사양은 주문제작으로 가능합니다.
The specifications of the split pin can be custom-made.

Hinge(Link) Clamp Standard Type



Features

- | | |
|------------------------------------|--|
| 1. 공압으로 작동 | 1. Operating by pneumatic pressure |
| 2. 편리한 배관 | 2. Easy piping |
| 3. 가스연질화 표면처리 | 3. Gas Nitriding Surface/Double-acting |
| 4. 내경범위 : ø15~63 | 4. Piston Diameter : ø15~63 |
| 5. 작동압력 : 3~9.9kgf/cm ² | 5. Operating Pressure : 3~9.9kgf/cm ² |
| 6. 사용온도 : 0~60°C | 6. Operating Temperature : 0~60°C |
| 7. 피스톤 속도 : 8~100mm/s | 7. Piston Speed : 8~100mm/s |
| 8. 레버는 옵션 | 8. Lever is option item |

> HGC - 15 19 A

① ② ③

① Piston Diameter(mm) ② Total stroke(mm) ③ Pneumatic Type

Specification

* 클램핑력은 표준치수 레버적용 기준임.

* The clamping force in the table below relates to the standard dimension lever.

MODEL NO.	HGC-1519A	HGC-2024A	HGC-2527A	HGC-3035A	HGC-4040A	HGC-5051A	HGC-6353A
Clamping Force(kgf)	9	16	25	35	63	98	156
Effective Area(cm ²)	1.76	3.14	4.90	7.06	12.56	19.62	31.15
Piston Diameter(mm)	ø 15	ø 20	ø 25	ø 30	ø 40	ø 50	ø 63
Stroke(mm)	Total	19	24	27	35	40	51
	Clamp	17	22	25	32	37	48
	Extra	2	2	2	3	3	3
Operating Pressure Range	3~9.9kgf/cm ²						
Operating Temperature Range	0~60°C						
Piston Speed	8~100mm/s						
Weight(kg)	0.23	0.37	0.54	1.24	1.70	2.86	4.29

Clamping Force Calculation Formula

Pneumatic Clamp

클램핑력은 치수 K와 사용압력에 따라 변합니다.
아래의 계산식을 통해 클램핑력을 구해 주십시오.

Clamping force varies depending on dimension K and operating pressure.
Use below formula to calculate clamping force.

- > F = Clamping Force(kgf)
- > P = Pneumatic Pressure(kgf/cm²)
- > K = 옆의 도면 참조 Refer to Drawing (mm)

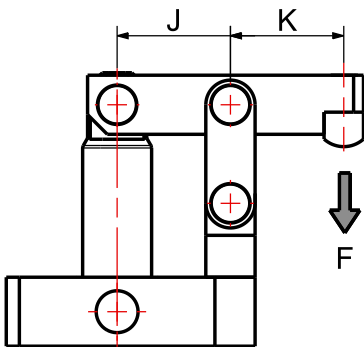

PNEUMATIC

$$\text{HGC-1519A} : F = 28.2 \times P / K$$

$$\text{HGC-2024A} : F = 62.8 \times P / K$$

$$\text{HGC-2527A} : F = 112.7 \times P / K$$

$$\text{HGC-3035A} : F = 211.8 \times P / K$$

$$\text{HGC-4040A} : F = 439.6 \times P / K$$

$$\text{HGC-5051A} : F = 882.9 \times P / K$$

$$\text{HGC-6353A} : F = 1,557.5 \times P / K$$

* K 치수: 카탈로그 치수의 30% 이상 커지는 것은 권장 안함.

K Dimension: It is not recommended to exceed 30% of the catalog dimension.

Drawing

Dimensions

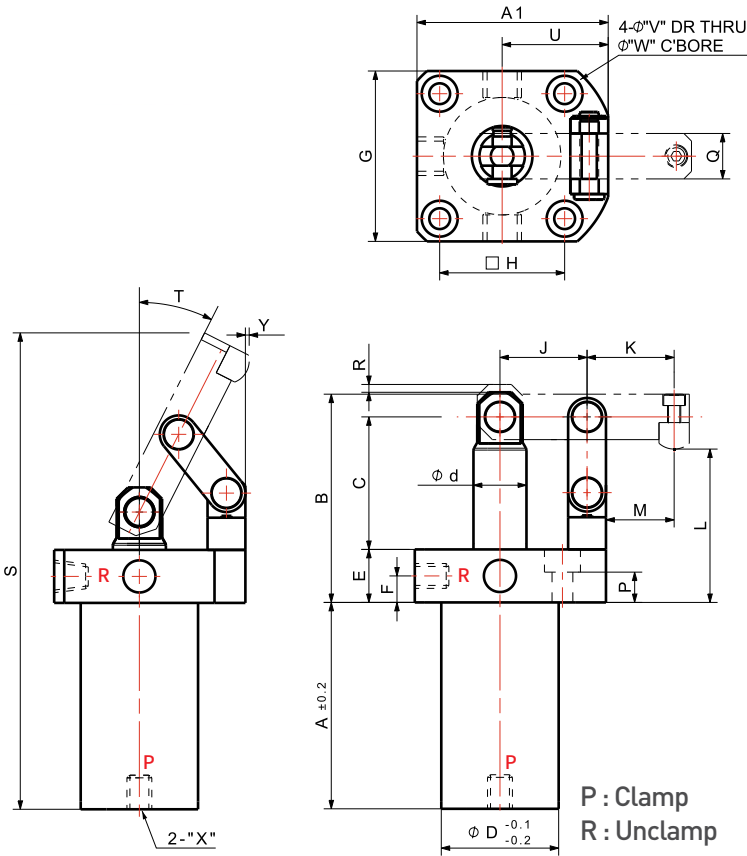

MODEL NO.	HGC-1519A	HGC-2024A	HGC-2527A	HGC-3035A	HGC-4040A	HGC-5051A	HGC-6353A
A	45	50	54.5	76.5	81.5	101.5	105
A1	37	45	50.5	64	74	91.5	105
B	43.5	49.5	55	78.5	83.5	96.5	100
C	26	31	35	50.5	55.5	67.5	69
øD	20	25	31	37	47	58	72
ød	8	12	14	18	20	22.4	28
E	13	14	14	18	18	20	20
F	5	5.5	7	9	9	10	10
G	32	40	45	52	62	77	88
H	22	28	33	37	47	57	67
J	16	20	23	30	35	45	50
K	16	20	23	30	35	45	50
L	31.5	37.5	40.5	57.5	62.5	75.5	75
M	11	15	18	22	27	37	39
P	8.5	8	8	11	10	11	11
Q	9	9	12	19	19	22	25
R	2	2	2	3	3	3	3
S	101.4	114.8	125.8	175.7	188.7	228.1	238.9
T	25.8°	25.1	26.8	26.3	28.5	29.5	33
U	21	25	28	38	43	53	61
V	4.5	5.5	5.5	7	7	9	9
W	8	9.5	9.5	11	11	14	14
X	M5	M5	PT 1/8	PT 1/8	PT 1/8	PT 1/8	PT 1/8
Y	0.3	0.7	1	0.6	1.3	3.3	6.9

Long Link Pin for Sensing

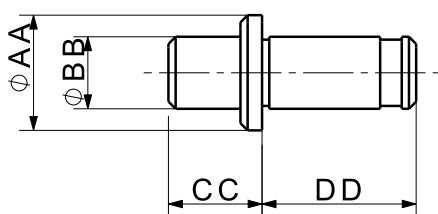

MODEL NO.	HGC-2024A	HGC-2527A	HGC-3035A	HGC-4040A	HGC-5051A	HGC-6353A
ØAA	8	8	10	10	10	13
ØBB	5	5	8	8	8	10
CC	9.5	10.5	9.0	14.0	17.5	21.0
DD	10.7	13.7	21.8	21.8	24.8	28.0

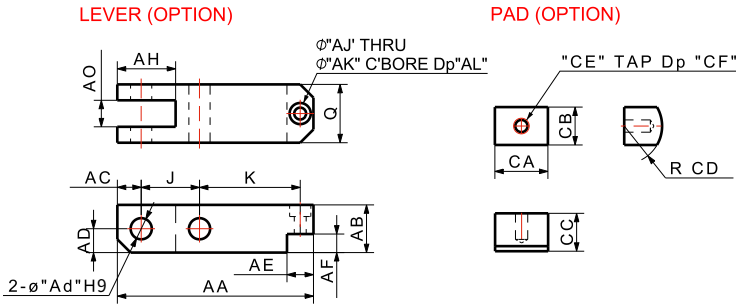

Dimensions

MODEL NO.	HGC-1519A	HGC-2024A	HGC-2527A	HGC-3035A	HGC-4040A	HGC-5051A	HGC-6353A
AA	40.5	49	56	74	84	104	117
AB	9	9	12	19	19	18	22
AC	4.5	5	6	9	9	9	11
AD	4.5	4.5	6	9	9	9	11
Ad	5	5	5	8	8	8	10
AE	8	8	8	10	10	10	12
AF	4	4	4.5	8	8	7	9
AH	12	13.5	14.5	23	23	22	26
AJ	3.5	3.5	3.5	4.5	4.5	4.5	6
AK	6	6	6	8	8	8	9.5
AL	3	3	3	4	4	4	6
AO	4	4	5	9	9	10	12
CA	8	8	8	14	14	14	16
CB	8	8	8	10	10	10	12
CC	7	7	7	10	10	10	12
CD	6	6	6	10	10	10	10
CE	M3	M3	M3	M4	M4	M4	M5
CF	4.5	4.5	4.5	6	6	6	6

Mounting Detail

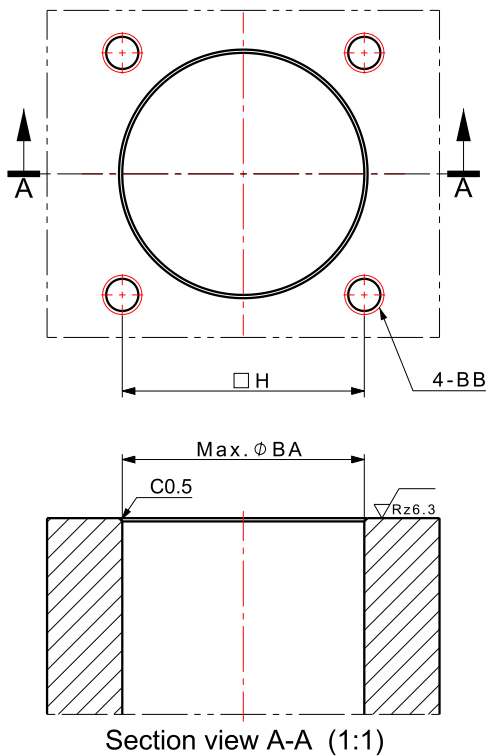

Dimensions

MODEL NO.	H	ØBA	BB
HGC-1519A	22.0	21.0	M4
HGC-2024A	28.0	26.0	M5
HGC-2527A	33.0	32.0	M5
HGC-3035A	37.0	38.0	M6
HGC-4040A	47.0	48.0	M6
HGC-5051A	57.0	59.0	M8
HGC-6353A	67.0	73.0	M8

공압용 제자리 스윙클램프 Parallel Swing Clamp for Pneumatic

제자리에서 회전 !! 회전 스트로크 0 !! Swing at one spot !! Swing stroke 0 !!

Operation

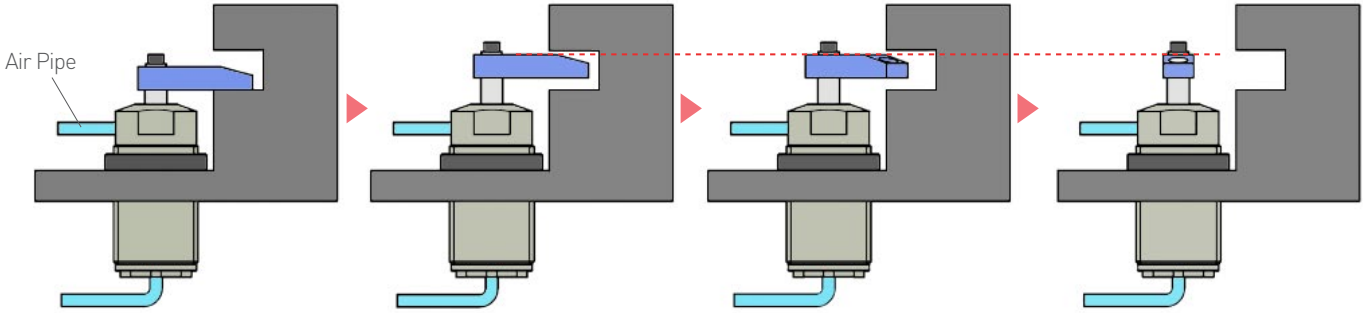

클램핑 & 언클램핑: 직진 스트로크
Clamping & Unclamping: Straight Stroke

회전: 제로 스트로크(제자리 스윙)
Swing: 0 Stroke(Swing at one spot)

클램핑/언클램핑 시 피스톤로드는 직진으로 정해진 스트로크 만큼 상하로 움직이나 피스톤로드가 90도로 회전할 땐, 제자리에서 상하로 움직임 없이(제로 스트로크) 스윙하며 상부에 있는 간섭을 피할 수 있습니다. (일반 스윙클램프는 회전 시 상하로 움직임)

When clamping/unclamping, the piston rod moves up and down as much as the set stroke in a straight line. When the piston rod rotates 90 degrees, it rotates at one spot without moving up and down (zero stroke). So, interference in the upper part can be avoided. (General swing clamp moves up and down when rotating)

Model No.

SSDR-3208A-30

SSDR	-	32	-	08	-	A	-	30
1		2		3		4		5

1 Swing Direction
SSDR = SWING RIGHT
SSDL = SWING LEFT

3 Piston Rod Stroke
ex) 08=8mm

5 Swing Angle
No sign = 90°
ex) 30 = 30°

2 Piston Diameter
ex)32 = 30mm

4 Type
> A = Pneumatic(Air)



NEW



제자리스윅 클램프 Parallel Swing Clamp

Features

1. 공압으로 작동되며 작은 고정력에 사용
 2. 가스연질화 표면처리
 3. 나사로 된 몸체를 이용한 손쉬운 설치
 4. 내경범위 : $\phi 25 \sim 50$
 5. 작동압력 : $3 \sim 9.9 \text{ kgf/cm}^2$
 6. 사용온도 : $0 \sim 60^\circ\text{C}$
 7. 레버 조립 시 고정 상태에서 볼트 체결
 8. 레버는 옵션 사항임
1. Operated by pneumatic and used for low clamping force
 2. Gas Nitriding Surface/Double-acting
 3. Easy installation with threaded body
 4. Piston Diameter : $\phi 25 \sim 50$
 5. Operating Pressure : $3 \sim 9.9 \text{ kgf/cm}^2$
 6. Operating Temperature : $0 \sim 60^\circ\text{C}$
 7. When assembling the lever, the bolts should be fastened in a fixed state.
 8. Lever is option item

> SSDR - 15 14 A

① ② ③ ④

① R=Right, L=Left ② Piston Diameter (mm) ③ Total Stroke(mm)
④ Pneumatic Type

Specification

* 파워업(클램프력 2배) 사양: 주문제작으로 가능.

MODEL NO.		SSD□-2508A	SSD□-3208A	SSD□-4010A	SSD□-5010A
Cylinder Force (kgf)	Max.	41.2	68.4	106.9	169.2
Piston Diameter (mm)		25	32	40	50
Effective Area (cm ²)		4.9	6.9	10.8	17.1
Stroke (mm)	Swing	0	0	0	0
	Straight	8	8	10	10
	Total	8	8	10	10
Swing Angle Tolerance (Repeated Accuracy)		$\pm 3^\circ (\pm 0.5^\circ)$			
Operating Pressure Range		3 ~ 9.9 kgf/cm ²			
Operating Temperature Range		0 ~ 60 °C			
Weight(kg)		0.8	1.1	4.1	4.5

언클램프 상태 비교 제자리 스윅 VS 일반 스윅



유량조절밸브 설치를 권장합니다.
Flow Control Valve installation is recommended.

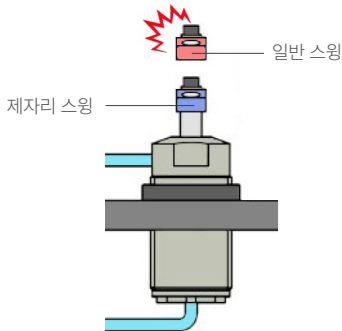

Swing Direction for Clamping

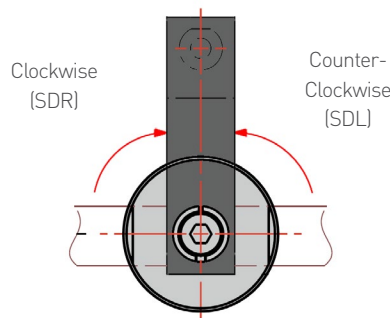

* 짧은 스트로크로 인해 상부 간섭을 피할 수 있음.
Due to the short stroke, upper interference can be avoided.

레버 조립 시 고정상태에서 볼트 체결할 것!
When assembling the lever, the bolts should be fastened in a fixed state.

Drawing

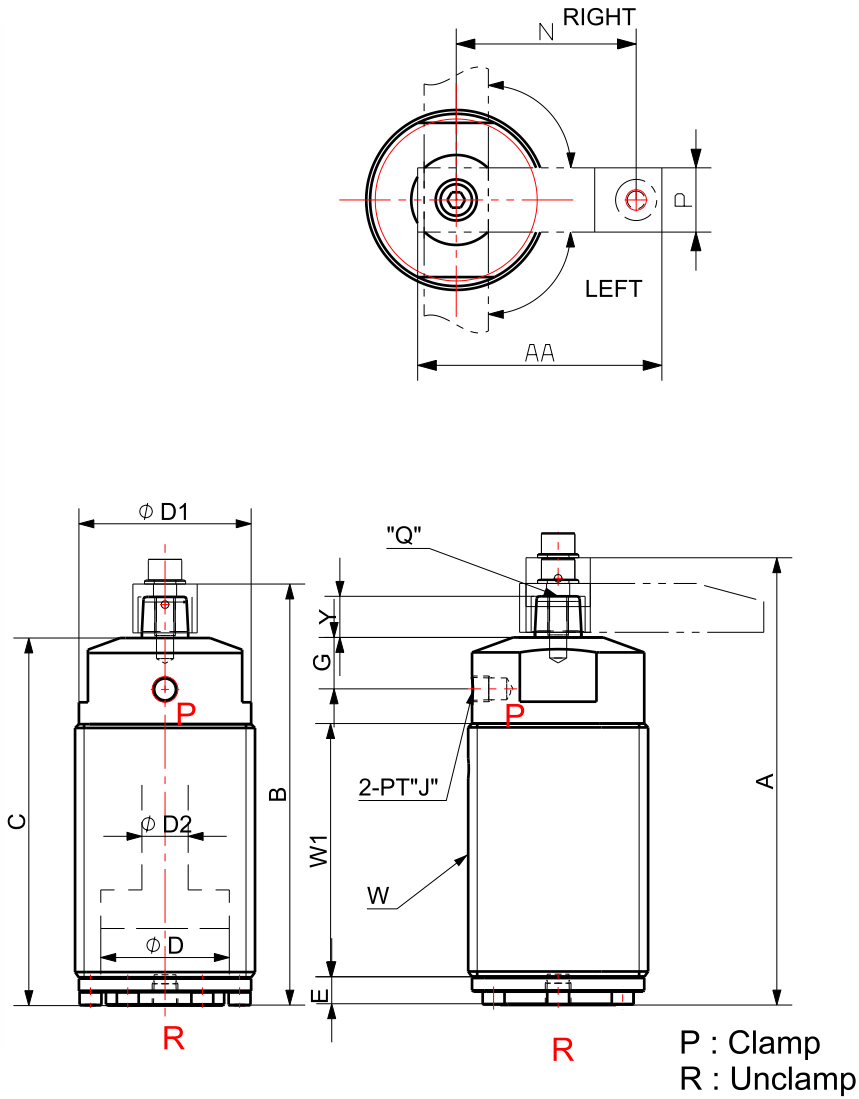

Dimensions

MODEL NO.	SSDx-2508A	SSDx-3208A	SSDx-4010A	SSDx-5010A	SSDx-6325A
A	116.5	126.5	151.5	174.0	237.0
B	108.5	118.5	141.5	164.0	212.0
C	89.0	97.5	121.0	143.0	185.5
øD	24.5	31.5	39.5	49.5	62.5
øD1	37.0	43.0	57.0	67.0	87.0
øD2	10.0	12.0	15.0	18.0	20.0
E	5.0	6.5	8.5	11.0	11.0
G	9.0	15.0	14.0	20.0	20.5
J	M5	PT 1/8	PT 1/8	PT 1/8	PT 1/4
L	16.0	19.0	19.0	19.0	24.0
L1	12.5	12.5	14.0	14.0	19.0
N	35.0	35.0	60.0	70.0	70.0
P	16.0	19.0	22.0	25.0	28.0
Q	M5	M6	M8	M8	M8
W	M40x1.5P	M45x1.5P	M60x2.0P	M70x2.0P	M90x2.0P
W1	64.0	91.0	87.5	98.5	136.0
Y	15.5	14.0	15.5	16.0	20.0

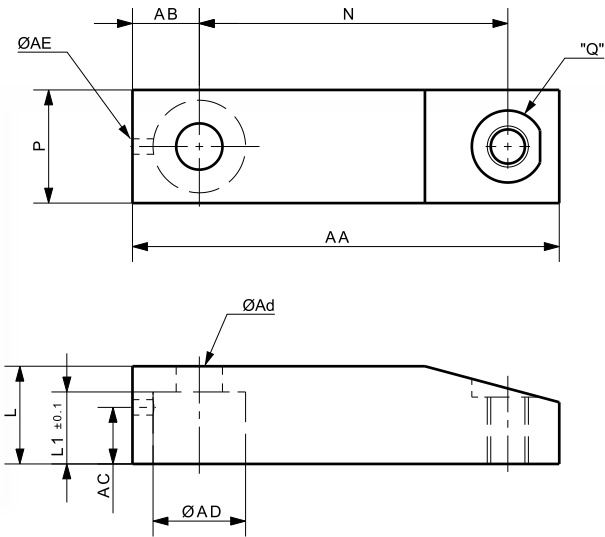

Dimensions

MODEL NO.	SSDx-2508A	SSDx-3208A	SSDx-4010A	SSDx-5010A	SSDx-6325A
AA	55.0	55.0	83.0	95.0	96.0
AB	12.0	13.0	13.0	15.0	16.0
AC	10.0	10.0	11.0	11.0	13.0
$\varnothing Ad$	6.0	7.0	9.0	9.0	11.0
$\varnothing AD$	13.0	15.0	18.0	21.0	23.0
$\varnothing AE$	3.0	3.0	3.0	3.0	3.0
L	16.0	19.0	19.0	19.0	24.0
L1	12.5	12.5	14.0	14.0	19.0

Mounting Base Accessories

> MBR - □□□□

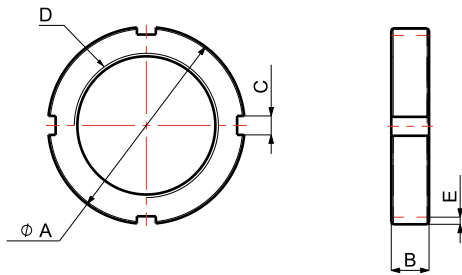

Dimensions

MODEL NO.	DIMENSIONS (mm)				
	$\varnothing A$	B	C	D	E
MBR-2010	32	10	4	M20 x P1.0	2.0
MBR-2510	38		5	M25 x P1.5	
MBR-3210	45		M32 x P1.5		
MBR-4010	58	11	6	M40 x P1.5	2.5
MBR-5011	70			M50 x P1.5	
MBR-6011	80		7	M60 x P1.5	
MBR-7012	92	12	8	M70 x P2.0	3.5

> MBS - □□□□

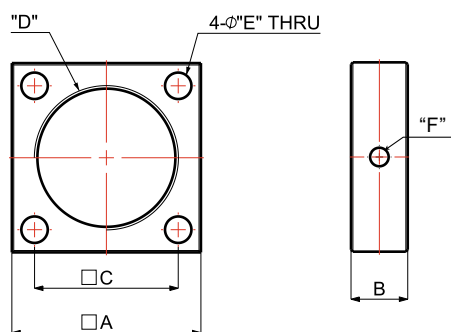

Dimensions

MOD-EL NO.	DIMENSIONS (mm)					
	A	B	C	D	E	F
MBS-2012	30	12	22	M20 x P1.0	4.5	M6 x P1.0
MBS-2512	38		28	M25 x P1.5	5.5	
MBS-3212	42		32	M32 x P1.5	7.0	
MBS-4012	50	12	40	M40 x P1.5	9.0	M8 x P1.25
MBS-5012	65			50		
MBS-6015	75		15	60		
MBR-7025	90	25	70	M70 x P2.0	11.0	

Swing Clamp Magnetic Sensor Type

마그네트 내장형. 클램프/언클램프 센싱! Built-In Magnetic Sensing Type !

Application

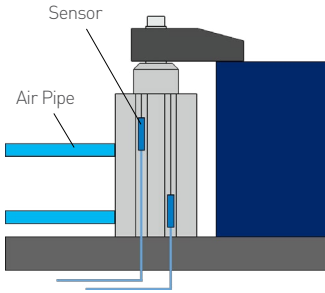

홈부착형 센서
Groove Attachment Sensor

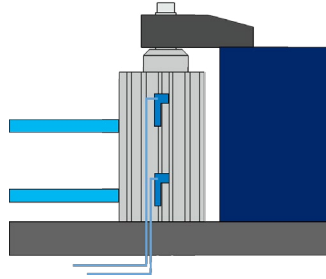

레일부착형 센서
Rail Attachment Sensor

Swing Direction for Clamping

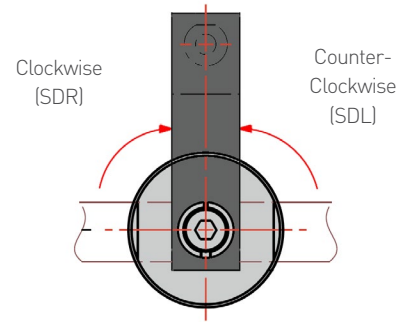

Model No.

SDR-2518AE



1 Swing Direction
For Clamping
SDR = Clockwise
(시계방향)
SDL = Counter-Clockwise
(반시계방향)

2 Piston Diameter
ex) 25 = $\varnothing 25$

3 Piston Rod Stroke
ex) 18 = 18mm

4 Type
> A = Pneumatic (Air)
> E = Sensing

3 Swing Angle
No sign = 90°
ex) 30 = 30°



Swing Clamp Magnetic Sensor Type



Features

1. 마그네트 내장형
 2. 클램핑/언클램핑 센싱
 3. 복동으로 작동
 4. 내경범위 : $\phi 20\sim 63$
 5. 작동압력 : $3\sim 9.9\text{kgf/cm}^2$
 6. 사용온도 : $0\sim 60^\circ\text{C}$
 7. 레버 조립 시 고정 상태에서 볼트 체결
 8. 레버는 옵션 사항임
1. Built-in magnet type
 2. Sensing for clamping/unclamping
 3. Double-acting
 4. Piston Diameter : $\phi 20\sim 63$
 5. Operating Pressure : $3\sim 9.9\text{kgf/cm}^2$
 6. Operating Temperature : $0\sim 60^\circ\text{C}$
 7. When assembling the lever, the bolts should be fastened in a fixed state.
 8. Lever is option item

> SDR - 25 18 AE

① ② ③ ④

- ① R=Right, L=Left ② Piston Diameter (mm) ③ Total Stroke(mm)
④ Pneumatic Magnetic Sensor Type

Sensor Attachment Method

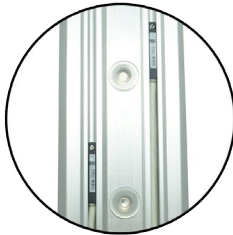

오토스위치 홈부착 방식

Groove attachment
* 센서는 옵션입니다.



오토스위치 레일부착 방식

Rail attachment
* The Sensor is an option.



레버 조립 시 고정상태에서 볼트 체결할 것!
When assembling the lever, the bolts should be fastened in a fixed state.

Specification

MODEL NO.	SDR / L-2018AE	SDR / L-2518AE	SDR / L-3225AE	SDR / L-4032AE	SDR / L-5032AE	SDR / L-6341AE
Weight (kg)	0.3	0.5	0.8	1.3	2.0	2.4
Cylinder Force (kgf)	Max.	23.3	40.8	68.4	106.9	227.4
	Min.	7.1	12.4	20.7	32.4	84.0
Piston Diameter (mm)	$\phi 20$	$\phi 25$	$\phi 32$	$\phi 40$	$\phi 50$	$\phi 63$
Effective Area (cm ²)	2.35	4.12	6.91	10.79	17.08	28.0
Stroke (mm)	Swing	9.0	8.0	15.0	17.0	18.0
	Straight	9.0	10.0	10.0	15.0	23.0
	Total	18.0	18.0	25.0	32.0	32.0
Swing Angle(Repeated Accuracy) Tolerance	$\pm 3^\circ (\pm 0.5^\circ)$					
Operating Pressure Range	$3 \sim 9.9 \text{ kgf/cm}^2$					
Operating Temperature Range	$0 \sim 60^\circ\text{C}$					

> Model No. **SDR/L-2018AE & 2518AE**

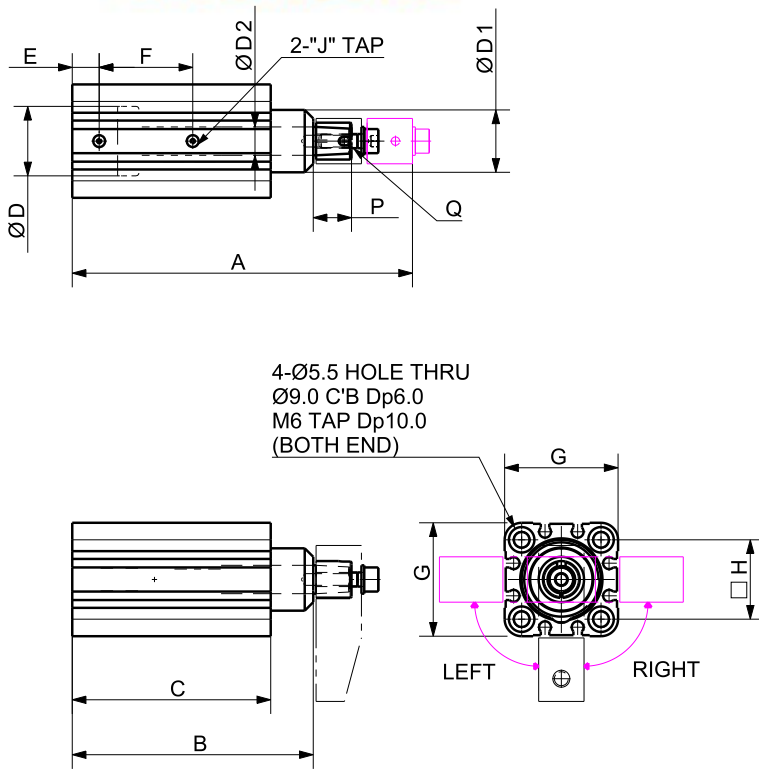

Dimensions

MODEL NO.	SDR/L-2018AE	SDR/L-2518AE
A	116	120
B	81	85
C	64.5	70
øD	20	25
øD1	17.5	22
øD2	10	10
E	8.5	9.5
F	32	33
G	36	40
G1	-	-
G2	-	-
H	25.5	28
J	M5	M5
P	13.5	13.5
Q	M5	M5

> Model No. **SDR/L-3225AE & 4032AE**

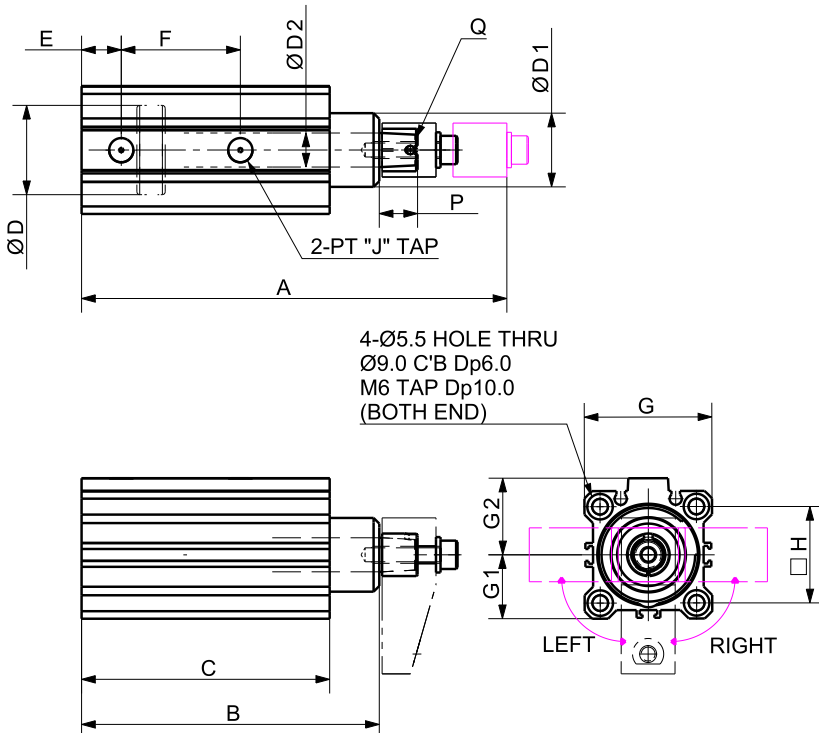

Dimensions

MODEL NO.	SDR/L-3225AE	SDR/L-4032AE
A	150	171
B	105	119
C	87.5	96.5
øD	32	40
øD1	26	33
øD2	12	15
E	14	12.5
F	42	49.5
G	45	52
G1	22.5	26
G2	27	31
H	34	40
J	PT 1/8	PT 1/8
P	13.5	15
Q	M6	M8

> Model No. **SDR/L-5032AE & 6341AE**

Dimensions

MODEL NO.	SDR/L-5032AE	SDR/L-6341AE	SDR/L-5032AE	SDR/L-6341AE	SDR/L-5032AE	SDR/L-6341AE			
DIMENSIONS (mm)	A	178	218.5	G	64	77	T	11	14
	B	123	153.5	G1	32	38.5	U	7	9
	C	100	116	G2	39	45.5	V	M8	M12
	øD	50	63	H	50	60	W	15	24
	øD1	42	48	J	PT 1/8	PT 1/8			
	øD2	18	20	P	16	21			
	E	14	16.5	Q	M8	M10			
	F	52	63.5	S	6.6	9.0			

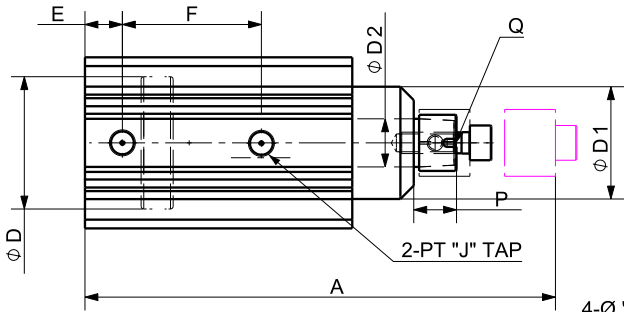

4-Ø "S" DR THRU
 Ø "T" C'B Dp"U"
 "V" TAP Dp"W"
 (BOTH END)

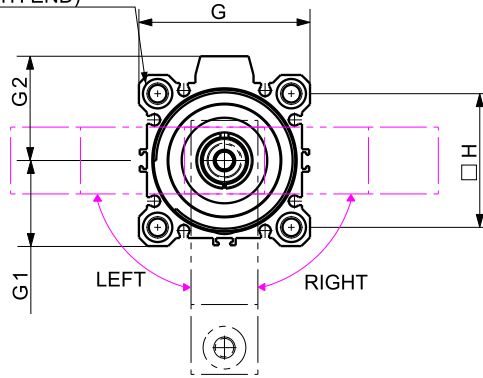
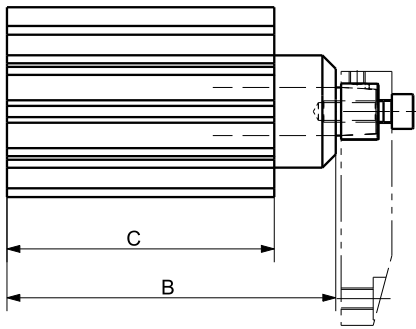

LEVER (OPTION)

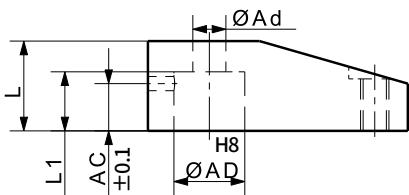
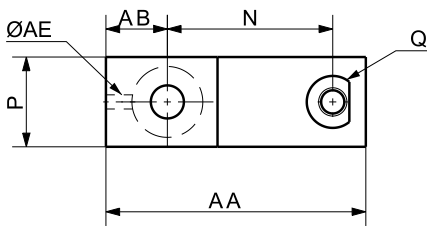

Dimensions

MODEL NO.	SDR/L-2018AE	SDR/L-2518AE	SDR/L-3225AE	SDR/L-4032AE	SDR/L-5032AE	SDR/L-6341AE	
DIMENSIONS (mm)	AA	45	55	55	83	95	96
	AB	10	12	13	13	15	16
	AC	10	10	10	11	11	13
	N	30	35	35	60	70	70
	P	16	16	19	22	25	28
	L	16	16	19	19	19	24
	L1	12.5	12.5	12.5	14	14	19
	Q	M5	M5	M6	M8	M8	M10
	øAd	5.5	6	7	9	9	11
	øAD	13	13	15	18	21	23
øAE	3	3	3	3	3	3	

Swing Clamp Pneumatic Clamp

Application

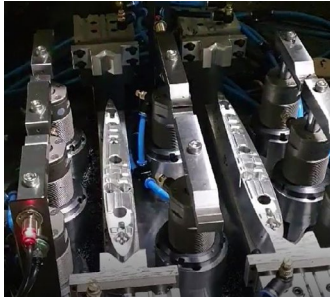

Piping Method

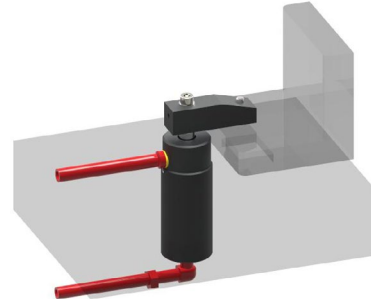

Model No.

SDR-1514A



- 1** Swing Direction
For Clamping
SDR = Clockwise (시계방향)
SDL = Counter-Clockwise (반시계방향)

- 2** Piston Diameter
ex) 15 = $\phi 15$

- 3** Piston Rod Stroke
ex) 14 = 14mm

- 4** Type
> A = Pneumatic(Air)

- 5** Swing Angle
No sign = 90°
ex) 30 = 30°



작동 영상

Swing Direction for Clamping

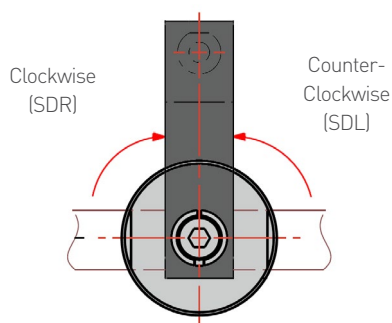

레버 조립 시 고정상태에서 볼트 체결할 것!

When assembling the lever, the bolts should be fastened in a fixed state.

Swing Clamp Standard Type



Features

1. 공압으로 작동되며 작은 고정력에 사용
 2. 가스연질화 표면처리
 3. 나사로 된 몸체를 이용한 손쉬운 설치
 4. 내경범위 : $\phi 15 \sim 50$
 5. 작동압력 : $3 \sim 9.9 \text{ kgf/cm}^2$
 6. 사용온도 : $0 \sim 60^\circ\text{C}$
 7. 레버 조립 시 고정 상태에서 볼트 체결
 8. 레버는 옵션 사항임
1. Operated by pneumatic and used for low clamping force
 2. Gas Nitriding Surface/Double-acting
 3. Easy installation with threaded body
 4. Piston Diameter : $\phi 15 \sim 50$
 5. Operating Pressure : $3 \sim 9.9 \text{ kgf/cm}^2$
 6. Operating Temperature : $0 \sim 60^\circ\text{C}$
 7. When assembling the lever, the bolts should be fastened in a fixed state.
 8. Lever is option item

> SDR - 15 14 A

① ② ③ ④

① R=Right, L=Left ② Piston Diameter (mm) ③ Total Stroke(mm)
④ Pneumatic Type

Specification

MODEL NO.		SDR / L-1514A	SDR / L-2018A	SDR / L-2518A	SDR / L-3025A	SDR / L-4032A	SDR / L-5032A
Weight (kg)		0.18	0.32	0.50	0.92	1.51	2.07
Cylinder Force (kgf)	Max.	12.5	22.1	40.8	58.8	106.9	169.1
	Min.	3.8	5.8	12.4	17.8	32.4	51.2
Piston Diameter (mm)		$\phi 15$	$\phi 20$	$\phi 25$	$\phi 30$	$\phi 40$	$\phi 50$
Effective Area (cm ²)		1.26	2.20	4.12	5.93	10.79	17.08
Stroke (mm)	Swing	7.0	9.0	8.0	15.0	17.0	17.0
	Straight	7.0	9.0	10.0	10.0	15.0	15.0
	Total	14.0	18.0	18.0	25.0	32.0	32.0
Swing Angle(Repeated Accuracy) Tolerance		$\pm 3^\circ (\pm 0.5^\circ)$					
Operating Pressure Range		3 ~ 9.9 kgf/cm ²					
Operating Temperature Range		0 ~ 60 °C					



유량조절밸브 설치를 권장합니다.

Flow Control Valve installation is recommended.

Special Types for Sensing (주문제작품)

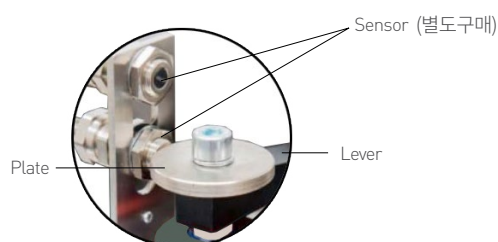

Drawing

* 4032A & 5032A에만 단진형상이 있음.

* Only 4032A & 5032A have shape for spanner.

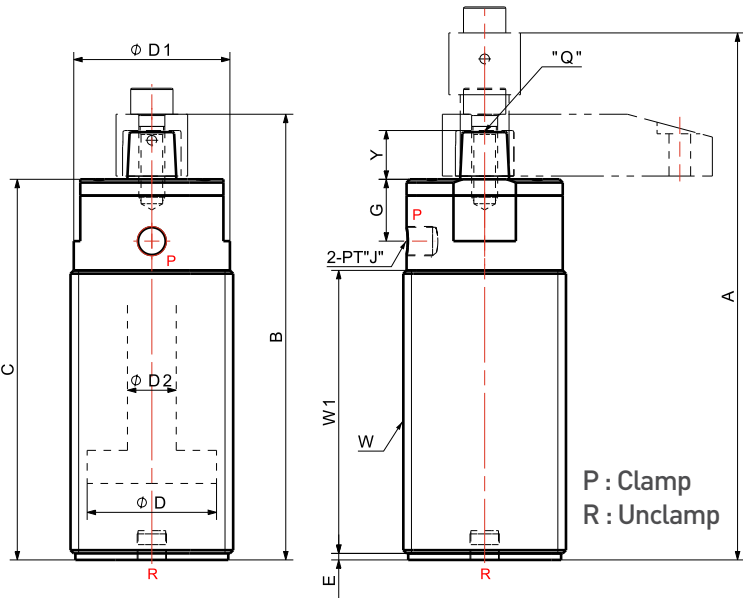
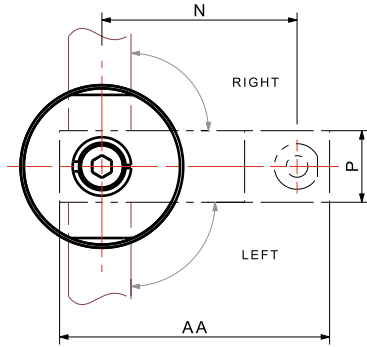

Dimensions

MODEL NO.	SDR/L-1514A	SDR/L-2018A	SDR/L-2518A	SDR/L-3025A	SDR/L-4032A	SDR/L-5032A
A	97	114	120	150	169	173
B	83	96	102	125	137	141
C	70	79	85	105	117	120
øD	15	20	25	30	40	50
øD1	18.5	23	30	38	48	58
øD2	8	10	10	12	15	18
E	4	3	2	2	2	16
G	11	11	12	12	19	17
J	M5	M5	M5	PT 1/8	PT 1/8	PT 1/8
L	12	16	16	19	19	19
L1	8.5	12.5	12.5	12.5	14	14
N	25	30	35	35	60	70
P	14	16	16	19	22	25
Q	M4	M5	M5	M6	M8	M8
W	M20 x 1.0P	M25 x 1.5P	M32 x 1.5P	M40 x 1.5P	M50 x 1.5P	M60 x 1.5P
W1	49.5	59	65	83	87	78
Y	9.5	13.5	13.5	13.5	15	16

* 레버를 제작해서 사용할 경우
가벼운 소재를 선택하십시오.

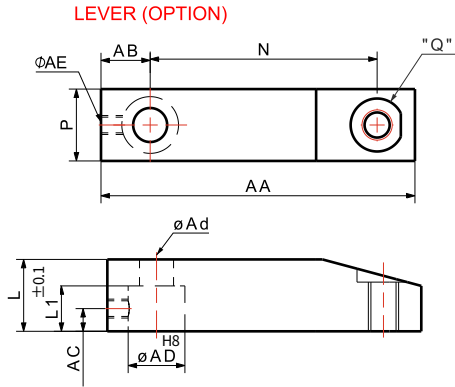

Dimensions

MODEL NO.	SDR/L-1514A	SDR/L-2018A	SDR/L-2518A	SDR/L-3025A	SDR/L-4032A	SDR/L-5032A
AA	38.5	45	55	55	83	95
AB	8.5	10	12	13	13	15
AC	7	10	10	10	11	11
Ad	4.5	5.5	6	7	9	9
AD	11	13	13	15	18	21
AE	2	3	3	3	3	3
L	12	16	16	19	19	19
L1	8.5	12.5	12.5	12.5	14	14

Mounting Base Accessories (별도 구매)

> MBR - □□□□

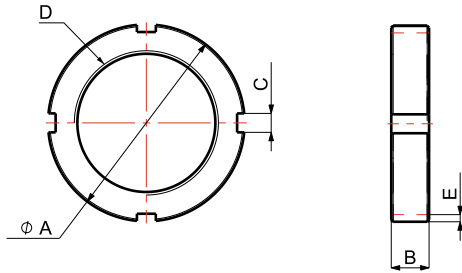

Dimensions

MODEL NO.	DIMENSIONS (mm)				
	φA	B	C	D	E
MBR-2010	32	10	4	M20 x P1.0	2.0
MBR-2510	38		5	M25 x P1.5	
MBR-3210	45		M32 x P1.5		
MBR-4010	58	11	6	M40 x P1.5	2.5
MBR-5011	70			M50 x P1.5	
MBR-6011	80		7	M60 x P1.5	

> MBS - □□□□

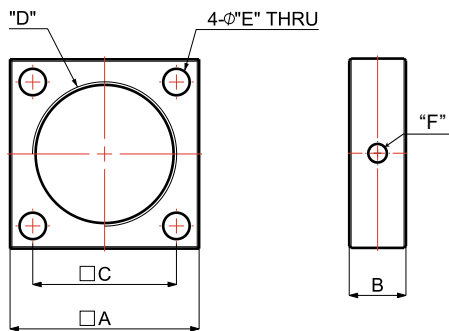

Dimensions

MOD-EL NO.	DIMENSIONS (mm)					
	A	B	C	D	E	F
MBS-2012	30	12	22	M20 x P1.0	4.5	M6 x P1.0
MBS-2512	38		28	M25 x P1.5	5.5	
MBS-3212	42		32	M32 x P1.5	7.0	
MBS-4012	50	15	40	M40 x P1.5	9.0	M8 x P1.25
MBS-5012	65		50	M50 x P1.5		
MBS-6015	75		60	M60 x P1.5		

Power Clamp Pneumatic Type

공압을 이용한 강력한 클램핑력!! Powerful clamping force using air pressure!!



Application

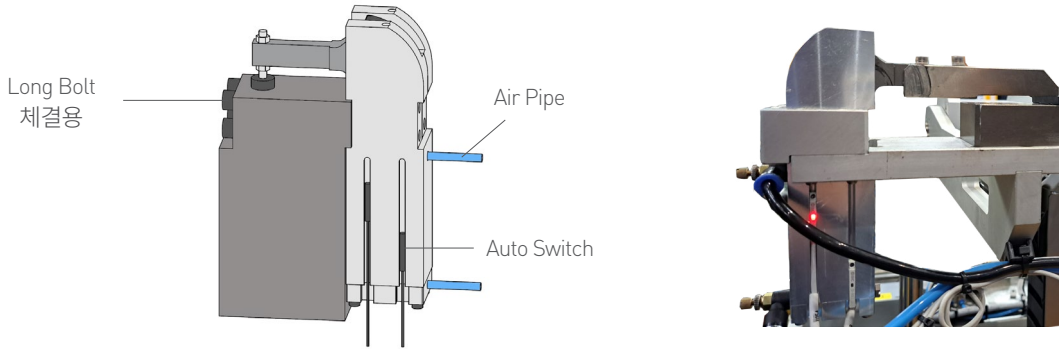

Model No.

PAC-1610AE

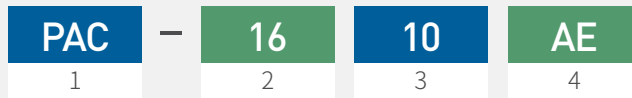

- 1** Clamp Type
PAC=Power Clamp
- 2** Piston Diameter
ex) 16= 16mm
- 3** Cylinder Force
ex) 10= 10kgf/cm²@5bar
- 4** Type
> A = Pneumatic (Air)

Specification

Model No.	Piston Diameter (mm)	Max. Clamping Force(kgf)@5bar	Max. Holding Torque (kgf.cm)	Operating Pressure Range (kgf/cm ²)	Operating Temperature Range(°C)	Weight(kg)
		Clamping Point(아래 이미지 참고)				
PAC-1610AE	16	D: 13/C: 15/B: 18/A: 25kgf	612	3-9.99	0-60	0.25
PAC-2626AE	26	D: 36/C: 45/B: 60/A: 89kgf	1014			0.5

Clamping Point

※ 주의사항
클램프력 발생을 위해 패드의 두께는 워크와 접촉했을 때(0.0mm) 보다 0.5mm 이내로만 더 두껍게 제작하십시오.

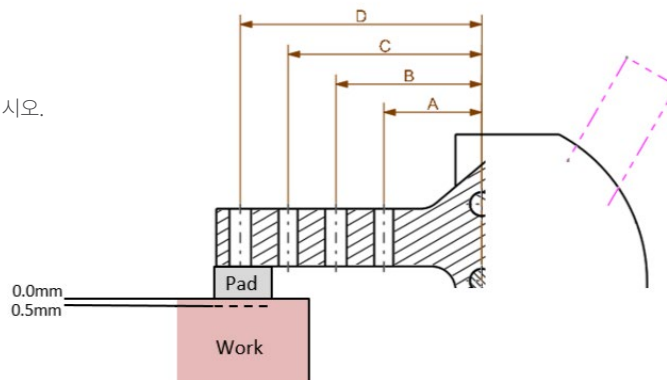

0.0mm: 클램프압이 수평이고 패드가 워크 표면과 접촉한 상태. 클램프력은 발생되지 않으나, 락기능은 발생됨. 락상태일 때 공압이 차단되면 누르는 힘은 작용되지 않음.

0.5mm를 초과할 시 언클램프 작동에 문제가 될 수 있음.

NEW



Clamping

Unclamping

Power Clamp

Standard Type

Features

1. 클램프암 조립되어 제공
2. 마그네트 내장형
3. 복동으로 작동
4. 클램핑 후 락기능 발생
5. 공압으로 작동
6. 내경범위: 16~26mm
7. 작동압력: 3~9.99kgf/cm²
8. 사용온도: 0~60°C

> PAC - 16 10 AE

① ② ③ ④

- ① Power Clamp ② Piston Diameter(mm) ③ Cylinder Force
④ Pneumatic Sensing

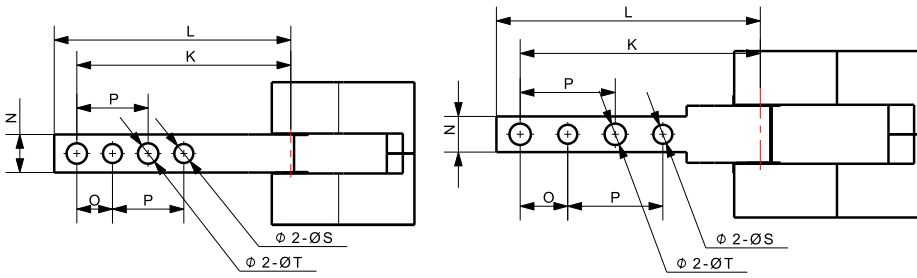

<PAC-1610AE : ARM 형상>

<PAC-2626AE : ARM 형상>

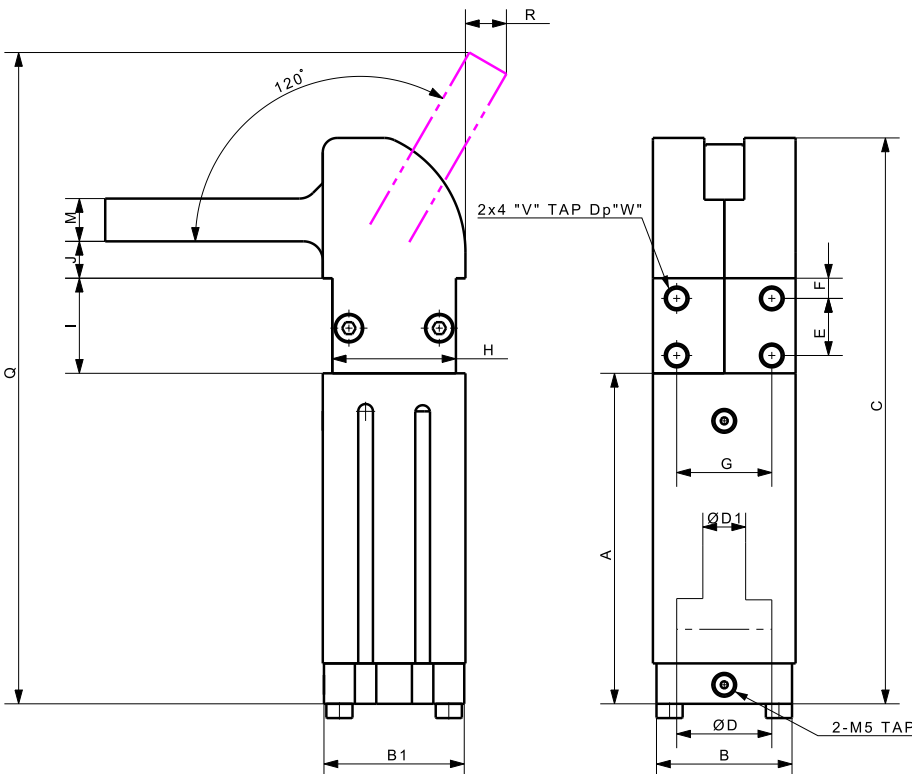

Model No.	PAC-1610AE	PAC-2626AE
A	69.5	83.5
B	29.0	35.0
B1	30.0	40.0
C	119.0	148.0
ØD	16.0	26.0
ØD1	8.0	10.0
E	12.0	15.0
F	4.3	5.0
G	20.0	20.0
H	26.0	34.0
I	20.0	25.0
J	7.7	12.0
K	45.0	50.5
L	49.8	55.5
M	9.0	12.0
N	8.0	7.5
O	7.5	10.0
P	15.0	20.0
Q	137.2	164.0
R	8.7	6.2
S	4.0	4.0
Y	4.3	4.5
V	5.0	6.0
W	6.0	7.0

Auto Coupler Threaded Type



작동 영상

유체회로 연결을 위한 자동 커플러 Coupler for connecting fluid circuit

사용가능 유체: 공압용, 양압/음압 겸용!! Available fluids: Pneumatic, Positive/Negative!!

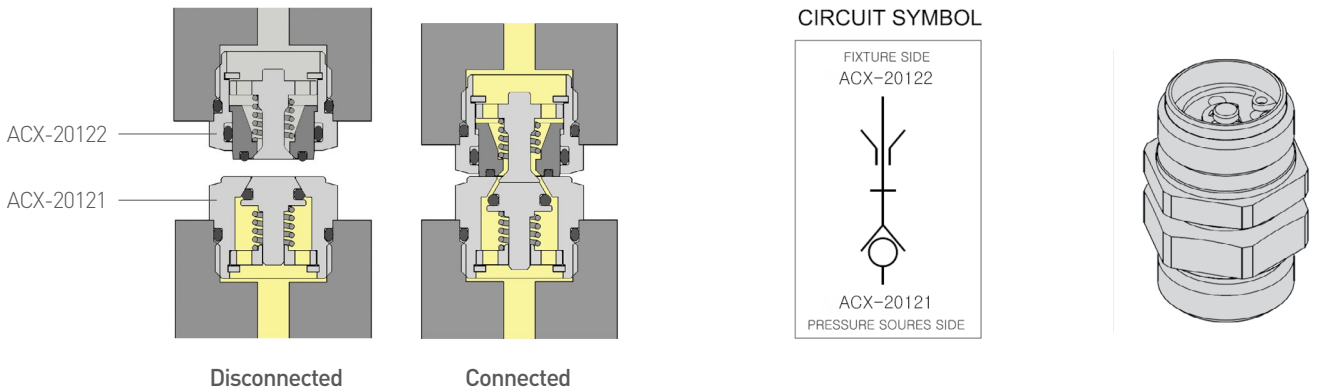

Model No.

ACX-20121



1 Fluid
ACX = Pneumatic & Hydraulic

2 Body Diameter
ex) 20 = M20

3 Side Type
1 = Pressure Source Side
2 = Fixture side

Specification

MODEL NO.	Weight	Max. Operating Pressure(kgf)	Operating Temperature	Coupling Stroke	Max. Reaction Force	Max. Area	Tightening Torque	Flow Rate
ACX-20121	33g	70kgf/cm ²	0~70°C	1.5mm	112kgf@70kgf/cm ²	12.6mm ²	250kgf.cm	16L/min@70kgf/cm ²
ACX-20122	34g							

NEW



ACX-20121
(압력공급부)



ACX-20122
(지그부)

Auto Coupler Threaded Type

Features

1. 공압용, 진공 가능
2. 유체회로 연결을 위한 커플러
3. 자동화에 알맞은 컴팩트 사이즈
4. 반동력: 112kgf@70kgf/cm²
5. 사용압력: Max. 70kgf/cm²

1. Pneumatic, Vacuum capable
2. Coupler for connecting fluid circuit
3. Compact and suitable for automatic
4. Reaction Force: 112kgf@70kgf/cm²
5. Operating Press.: Max. 70kgf/cm²

> ACX-20121

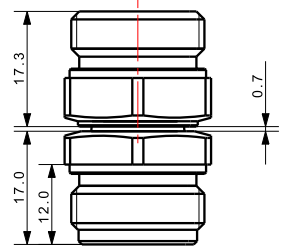
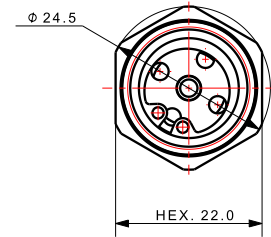
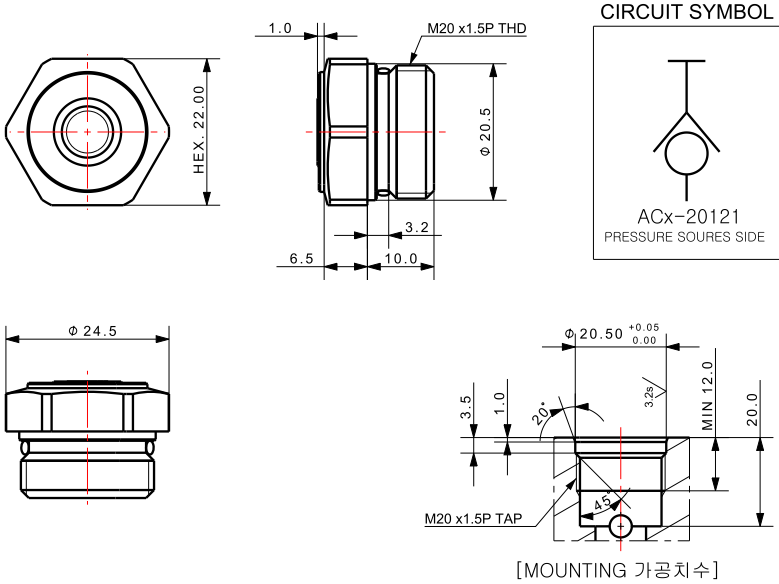

편심량: +/-0.5mm
각도공차: 0.3도

CIRCUIT SYMBOL

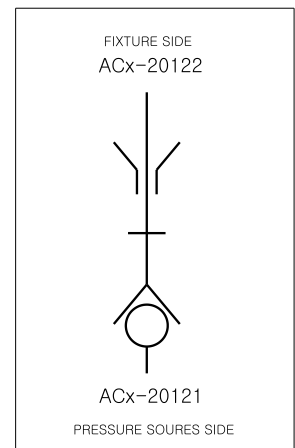

> ACX-20122

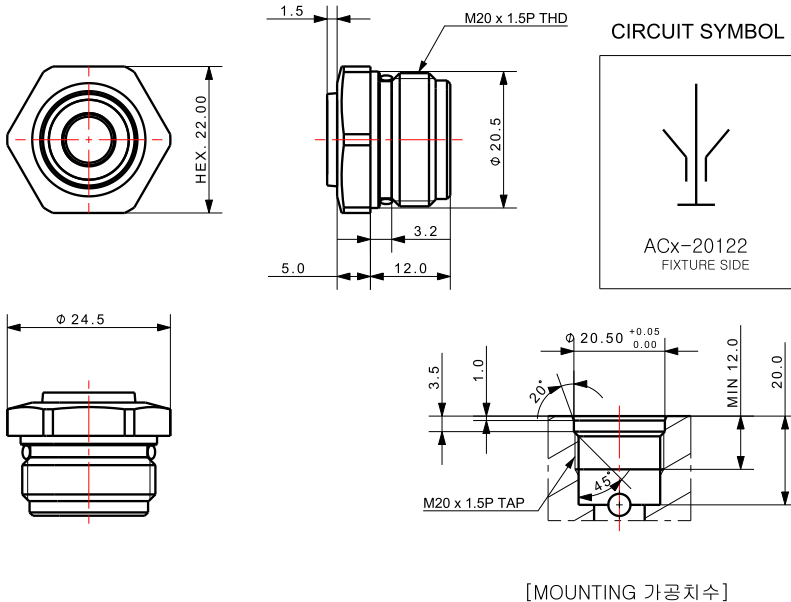

Auto Coupler Threaded Type

유체회로 연결을 위한 자동 커플러 Coupler for connecting fluid circuit



Application

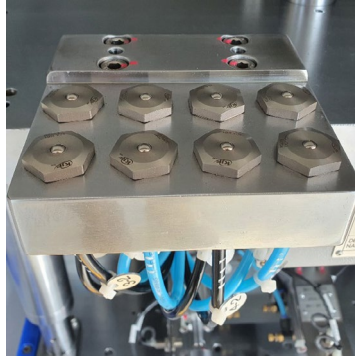

Operation

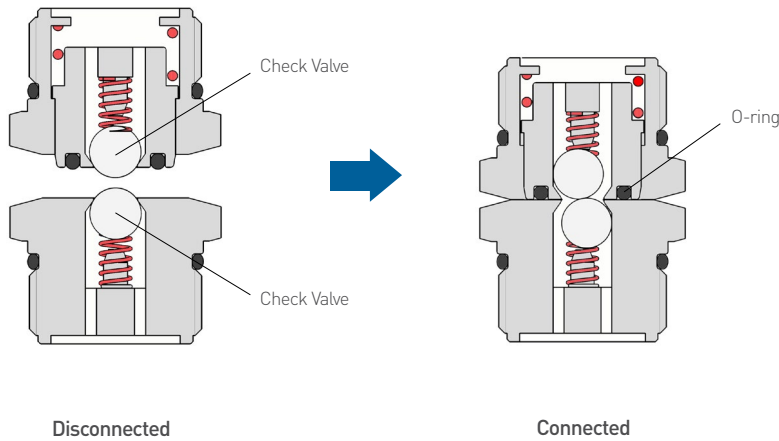

1. 상측과 하측이 분리상태일 때 체크밸브에 의해 유체 자동 차단.
2. 상측과 하측이 연결상태일 때 체크밸브가 서로를 누르면서 개방. 상측 끝단의 O-ring들이 공기 누출을 차단.

1. When the upper and lower side are disconnected, fluid is shut off automatically.
2. When the upper and lower side are connected, one check valve pushes the other to open. O-ring on the end of upper side blocks leaking air.

Model No.

ACA-2001



1 Fluid
ACA = Air(Pneumatic)

2 Body Diameter
ex) 20 = M20

3 Side Type
01 = Pressue Source Side
02 = Fixture side

Specification

MODEL NO.	Flow Rate	Max. Operating Pressure(kgf)	Operating Temperature	Usable Fluid	Weight (g)
ACA-2001	345L/min @4kgf/cm ²	10	0-70°C	Air	38
ACA-2002		10	0-70°C	Air	34

> ACA-2001

> ACA-2002

항동 슬리브
Brass Sleeve



Auto Coupler Threaded Type

Features

1. 작동압력범위 : 10kgf/cm² 이하
 2. 유체회로 연결을 위한 커플러
 3. 자동화에 알맞은 컴팩트 사이즈
 4. 반동력: 12kgf at 5kgf/cm²
 5. 공압용
1. Operating Pressure Range : lower than 10kgf/cm²
 2. Coupler for connecting fluid circuit
 3. Compact and suitable for automatic
 4. Reaction Force: 12kgf at 5kgf/cm²
 5. For Pneumatic

연결 상태 >>

상측과 하측이 접촉할 때, 한 쪽의 체크밸브가 다른 쪽의 체크밸브를 눌러 개방시킨다.

Connected State >>

When upper contacts with lower coupler, one check valve pushes the other to open.



* ACA-2001K / ACA-2002K
스테인레스 재질
Stainless Material

>ACA-2001

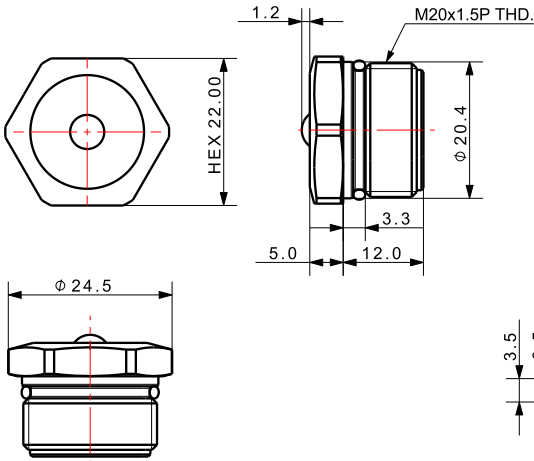

CIRCUIT SYMBOL

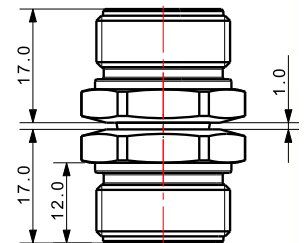
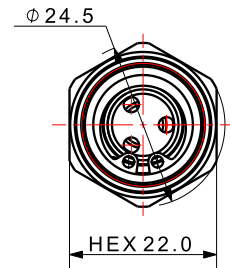
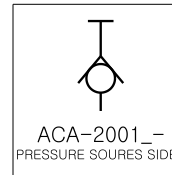

[MOUNTING 가공치수]

>ACA-2002

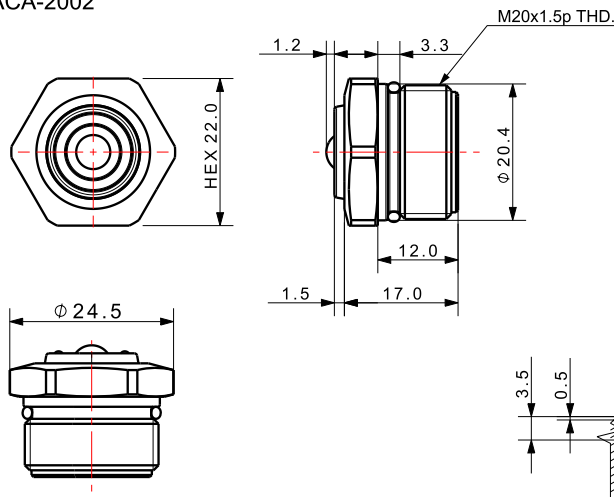

CIRCUIT SYMBOL

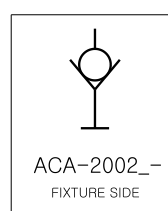

편심량: +/- 1.0mm
각도공차: 0.3도

CIRCUIT SYMBOL

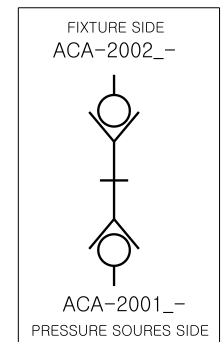

[MOUNTING 가공치수]

Rotary Joint Pneumatic Type

회전하는 기계부품에 공압을 연결! Connect pneumatic pressure to rotating machine parts!

Application

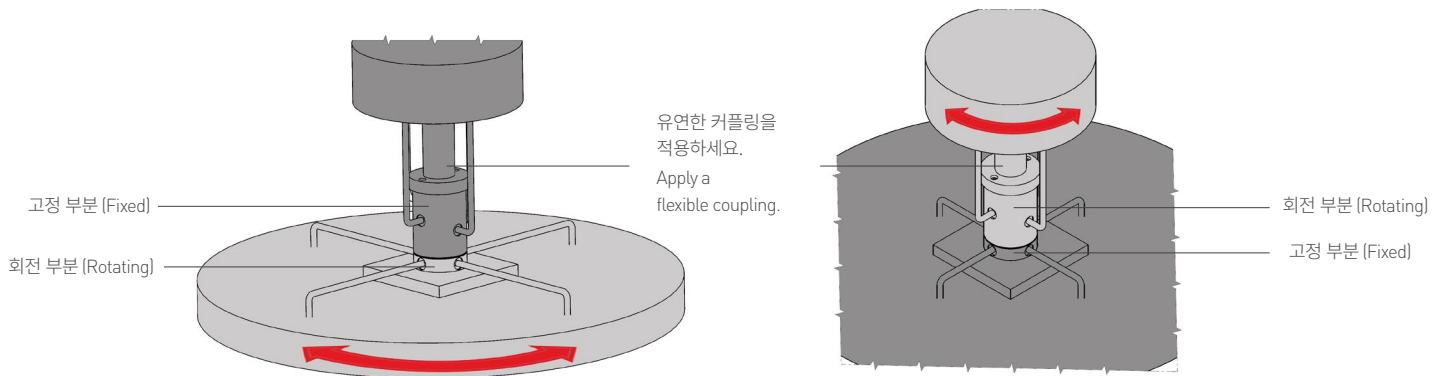

Specification

MODEL NO.	RTCH-0202A	RTCH-0404A	RTCH-0808A
Number of Lines	2	4	8
Fluid		Air	
Max. Operating Pressure		3~9.9kgf/cm ²	
Max. Revolutions per Minute		900 rpm	
Operating Temperature Range		0~70 °C	
Weight	0.16kg	0.40kg	0.76kg

* 슬립링(Slip Ring) 사양은 주문제작 가능.
포트 1/8 사이즈 주문제작 가능

NEW



Rotary Joint Pneumatic Type

Features

- | | |
|-----------------------------------|--|
| 1. 안정적인 회전토크 | 1. Stable rotational torque |
| 2. 회전체에 공압을 연결 | 2. Connect pneumatic pressure to the rotating body |
| 3. 배관고임 방지 | 3. Prevent hose/tube twisting |
| 4. 사용유체: 공압 | 4. Working fluid: Pneumatic (air) |
| 5. 작동압력: 3~9.9kgf/cm ² | 5. Operating pressure: 3~9.9 kgf/cm ² |
| 6. 사용온도: 0~70°C | 6. Operating temperature: 0~70°C |
| 7. 최대허용회전수: 900 rpm | 7. Max. rotation speed: 900 rpm |

RTCH-0202A

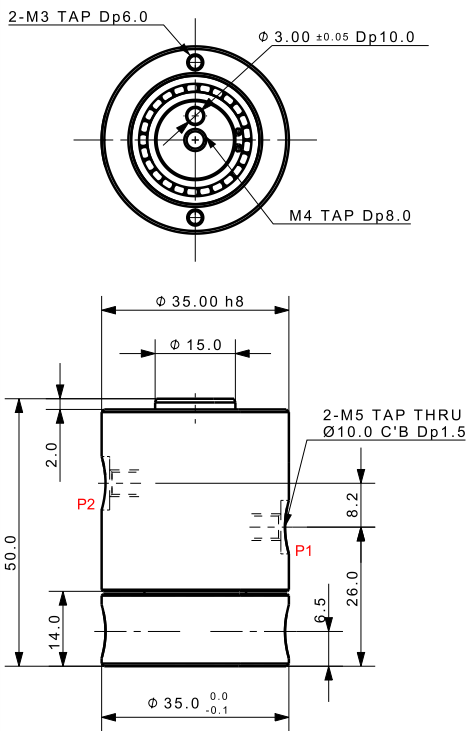

RTCH-0404A

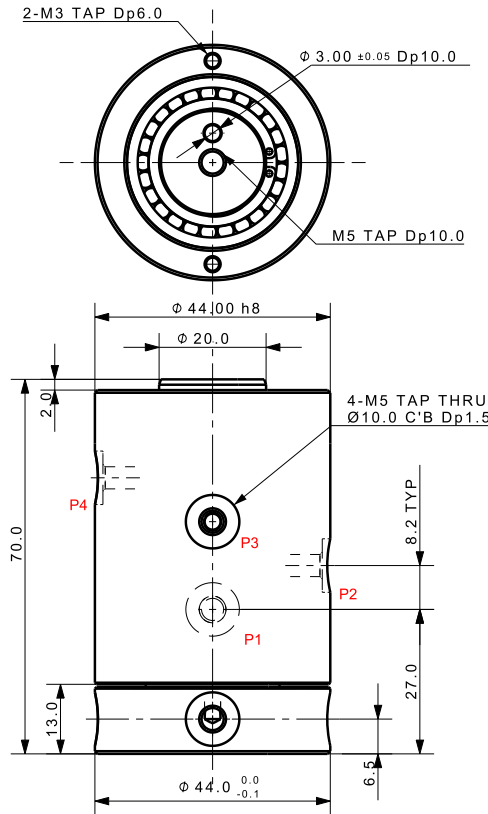

RTCH-0808A

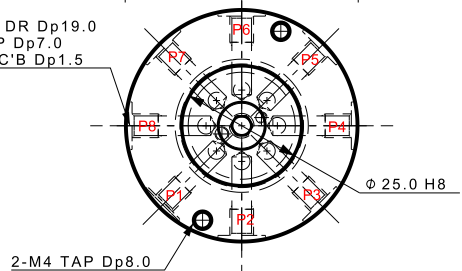
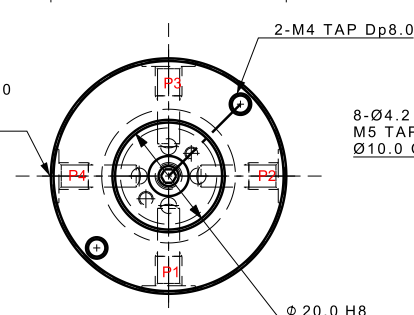
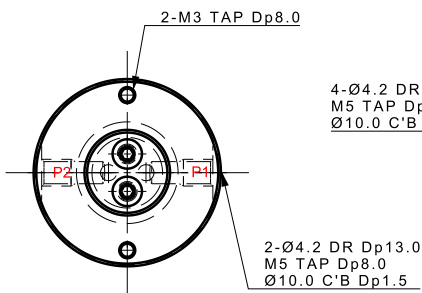
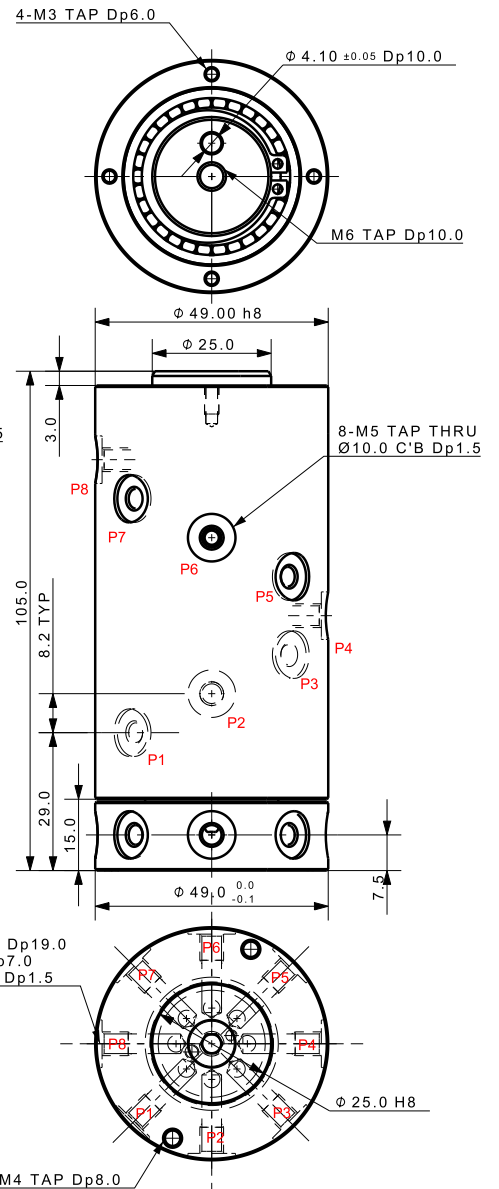

Work Support Pneumatic Type(공압용)



Application

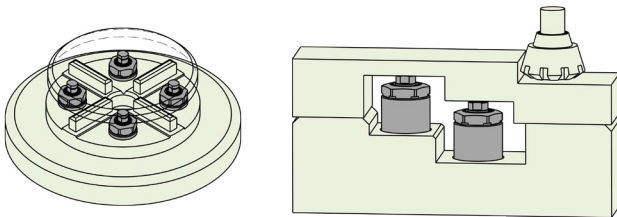

Operation

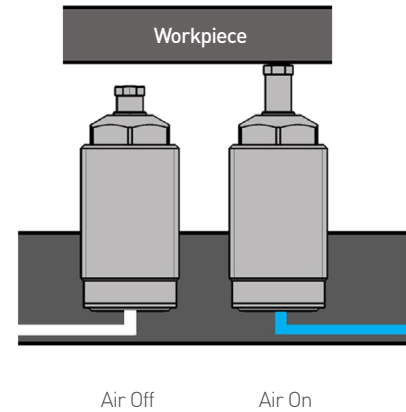

Model No.

CWS-10062A

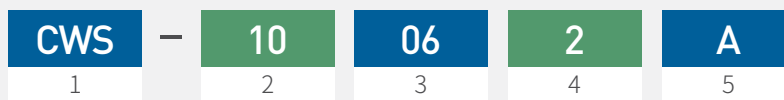

1 CWS = Work Support

2 Plunger Diameter
ex) 10=10mm

3 Stroke
ex) 06=6mm

4 Operation Method
Pneumatic Advance

5 Type
A = Air(Pneumatic)

Specification

MODEL NO.	CWS-10062A
Operation Method	Pneumatic Advance
Support Force(kgf) at 6kgf/cm ²	103.0
Plunger Stroke (mm)	6.5
Plunger Diameter (Ø)	10.0
Plunger Spring Froce (kgf)	0.22~0.29
Operating Pressure Range	4.0~6.0kgf/cm ²
Operating Temperature Range	0~70°C
Weight (kg)	0.28

NEW



Work Support Built-In Type(공압용)

Features

- | | |
|---------------------------------|---|
| 1. 강력한 서포팅 | 1. Strong support |
| 2. 스테인레스 바디 | 2. Stainless steel body |
| 3. 2단 작동 방식 | 3. Two-stage operation |
| 4. 작동압력: 4~6kgf/cm ² | 4. Operating press.: 4~6 kgf/cm ² |
| 5. 사용온도: 0~70°C | 5. Operating temp.: 0~70°C |
| 6. 체결토크: 250kgf.cm | 6. Tightening torque: 250 kgf.cm |
| 7. 과도한 힘으로 결합시 불량률의 원인이 됨. | 7. Excessive force during assembly may cause defects. |

> CWS - 1006A

① ② ③

① Plunger Diameter ② Stroke ③ Pneumatic Type

> Model No. CWS-1006A

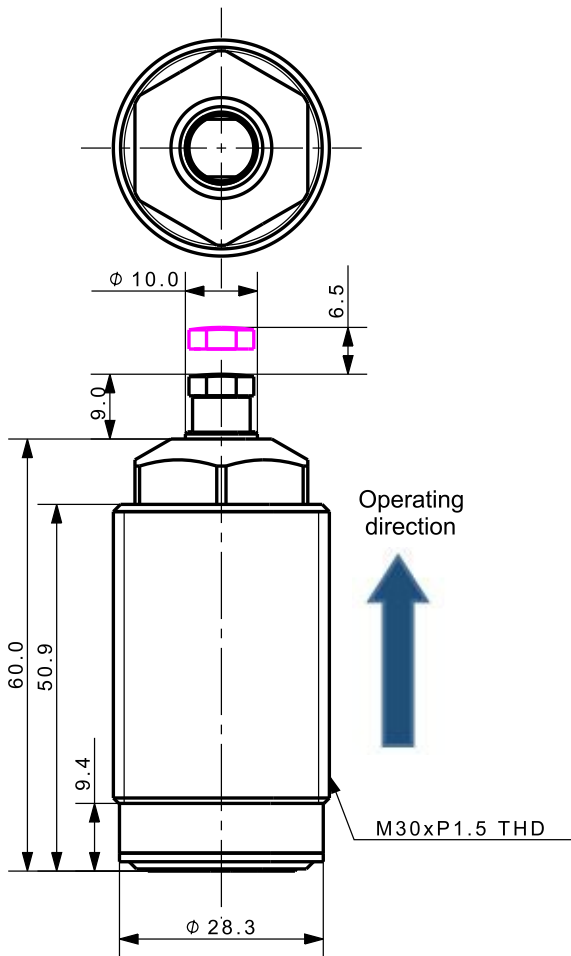

2단 (Hydraulic Advance)

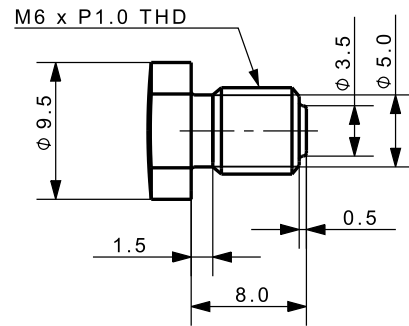

PAD DIMENSIONS

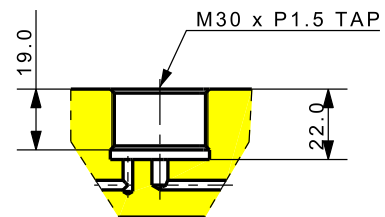
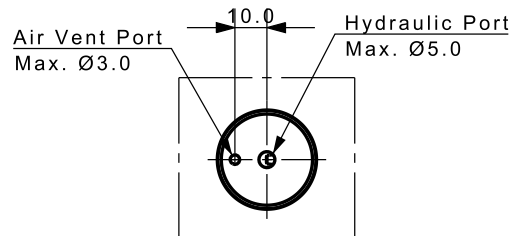

Mounting Dim.

* 에어벤트를 이물질이 침입하지 않는 범위로 개방시켜야 함.

초정밀 로케이터 Ultraprecision Locator

초정밀 위치결정, 반복정밀도 3 μ m! Ultraprecision Locating, 3 μ m Repeatability!

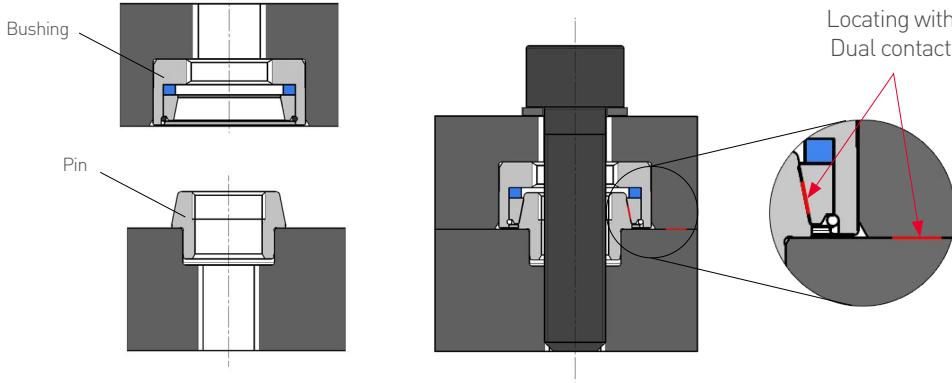

이중 접촉으로 인한 초정밀도로 고품질과 불량률 감소를 실현 시킵니다.

The Ultraprecision by dual contact offers excellent quality and a low percent defective.

Application

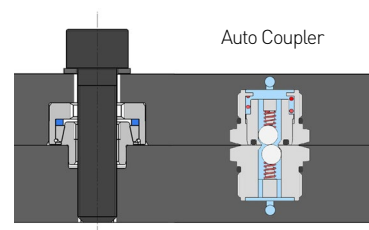
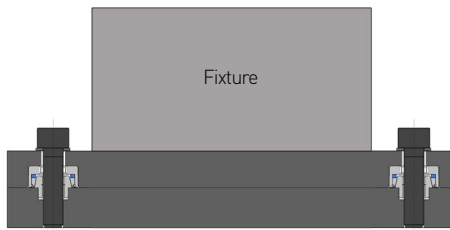

[How to mount and remove]

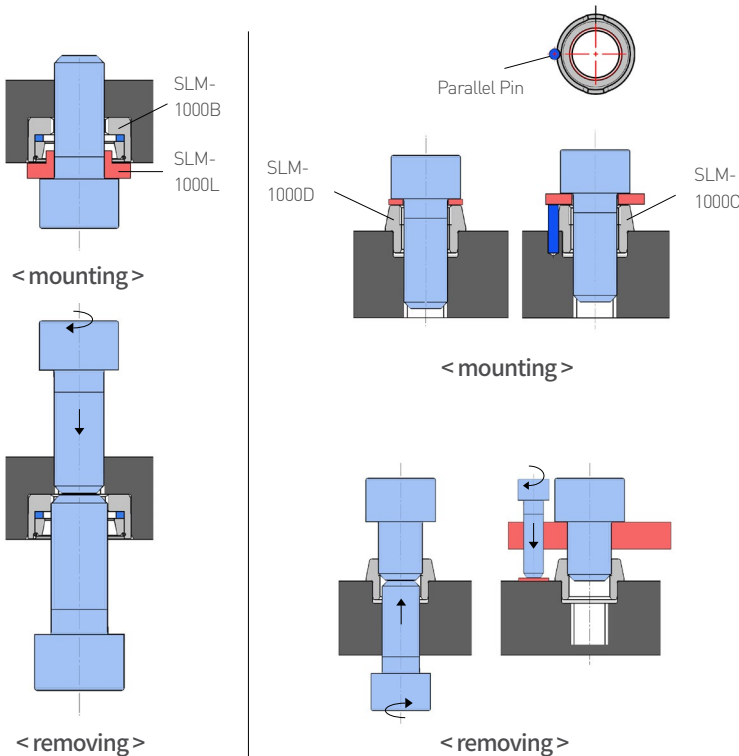

Model No.

- SLM-□00D: Pin
- SLM-□00C: Pin with Notch
- SLM-□00B: Bushing
- SLM-□00L(option): Locating Bushing

Specification

MODEL NO.		SLM - 1000□
Repeatability (mm)		0.003
Stroke (mm)		0.3
Max. Loading Weight (kg)	Horizontal	500
	Vertical	100
Min. Tightening Force (kgf)		203
Operating Temperature (°C)		0~70
Weight (kg)	Pin	0.01
	Bushing	0.024

주의: 핀의 테이퍼 부분을 보호하기 위해 가이드핀을 설치해 주십시오.

Caution: Please install guide pins for protecting the taper part of the pin.

초정밀 로케이터 Ultraprecision Locator



Features

- | | |
|---------------------------|---|
| 1. 간단한 설치 | 1. Simple Installation |
| 2. 반복정밀도: 3 μ m | 2. Repeatability: 3 μ m |
| 3. 컴팩트한 사이즈 | 3. Compact Size |
| 4. 로드중량: Max.~500kg | 4. Load Weight: Max.~500kg |
| 5. 체결력: Min. 203kgf~ | 5. Tightening Force: Min. 203kgf~ |
| 6. 사용온도: 0~70°C | 6. Operating Temperature: 0~70°C |
| 7. 위치결정만 가능
(클램프기능 없음) | 7. Locating function only
(No clamping function) |
| 8. 수동에 의한 위치결정 | 8. Locating by hand |

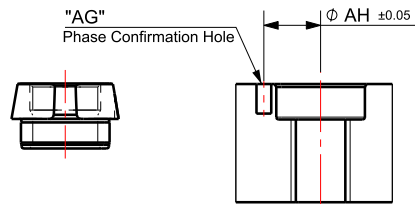
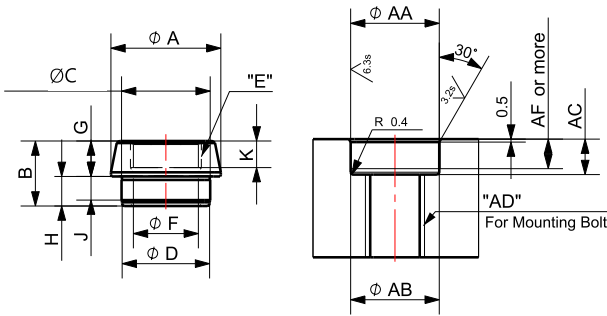
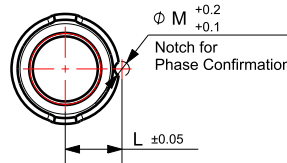
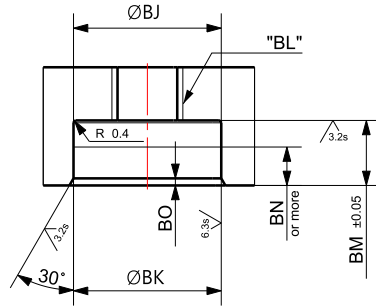
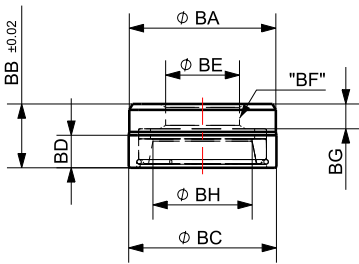

Dimensions

MODEL NO.	SLM-0600□	SLM-0800□	SLM-1000□	SLM-1200□
A	φ12.8	φ14.8	φ18.6	φ22.2
B	8.5	9	11	13
C	φ10.0 +0.024 +0.015	φ12.0 +0.029 +0.018	φ15.0 +0.029 +0.018	φ18.0 +0.029 +0.018
D	φ9.8	φ11.8	φ14.8	φ17.8
E	M8x 1.25P	M10x 1.5P	M12x 1.75P	M16x 2.0P
F	φ6.8	φ8.5	φ11.0	φ14.0
G	4.5	5	6	7
H	4	4	5	6
J	2.9	3.2	4	4.4
K	3.5	3.5	4.5	5.0
L	6.5	7.6	9.6	11.4
M	φ1.5	φ2.0	φ2.5	φ3.0
AA	φ10.0 +0.009	φ12.0 +0.011	φ15.0 +0.011	φ18.0 +0.011
AB	φ10.0 +0.009 -0.1	φ12.0 +0.011 -0.1	φ15.0 +0.011 -0.1	φ18.0 +0.011 -0.1
AC	5.0	5.0	6.0	7.0
AD	M6 x 1.0P	M8 x 1.25P	M10 x 1.5P	M12 x 1.75P
AF	4.0	4.0	5.0	5.5
AG	φ1.50	φ2.0	φ2.5	φ3.0
AH	φ6.5	φ7.6	φ9.6	φ11.4
BA	φ17.8	φ19.8	φ24.8	φ29.8
BB	8.3	8.8	10.8	12.8
BC	φ18.0 +0.033 +0.02	φ20.0 +0.033 +0.02	φ25 +0.033 +0.02	φ30.0 +0.033 +0.02
BD	3.8	4.2	5.5	6.4
BE	φ9.0	φ11.0	φ12.5	φ16.5
BF	M10 x 1.5P	M12 x 1.75P	M14 x 2.0P	M18 x 2.5P
BG	3.2	3.5	4.2	5.2
BH	φ11.6 φ18.0 +0.011 -0.1	φ13.4 φ20.0 +0.013 -0.1	φ16.8 φ25.0 +0.013 -0.1	φ20.3 φ30.0 +0.013 -0.1
BK	φ18.0 +0.011 0	φ20.0 +0.013 0	φ25.0 +0.013 0	φ30.0 +0.013 0
BL	M8x 1.25P	M10x 1.5P	M12x 1.75P	M16x 2.0P
BM	8.5	9.0	11.0	13.0
BN	5.0	5.5	6.5	7.5
BO	0.8	1.0	1.2	1.5

[Note to mount Pin and Bushing]

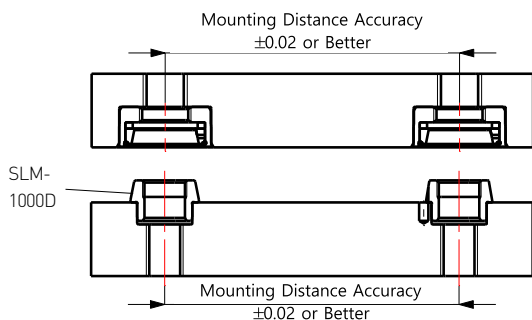

D type과 C type 핀들을 1세트만 설치하면 위치 결정이 됩니다. 볼트를 4개 이상 사용하여 상하판을 고정할 경우에는 핀들을 대각선으로 설치 하십시오.

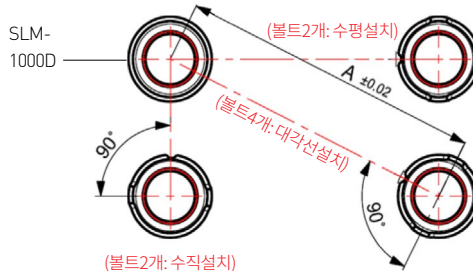

SLM-1000D센터와 SLM-1000C 홈은 90°로 정렬.
Align SLM-1000D center and SLM-1000C notch as 90°.

핀과 부싱을 결합할 때 볼트조임 순서는 SLM-1000D가 먼저입니다.
Tight bolt SLM-1000D first when pins and bushings are assembled.

에어시팅밸브 Air Seating Valve

에어 착좌 감지용! Air Seating Detection!

Operation

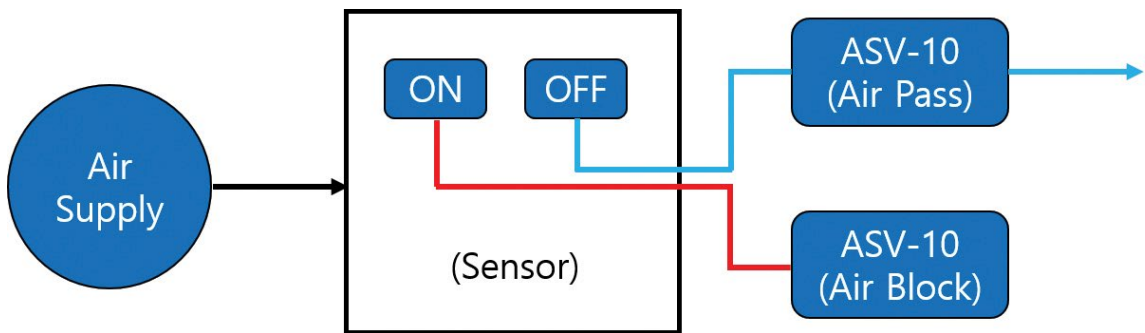
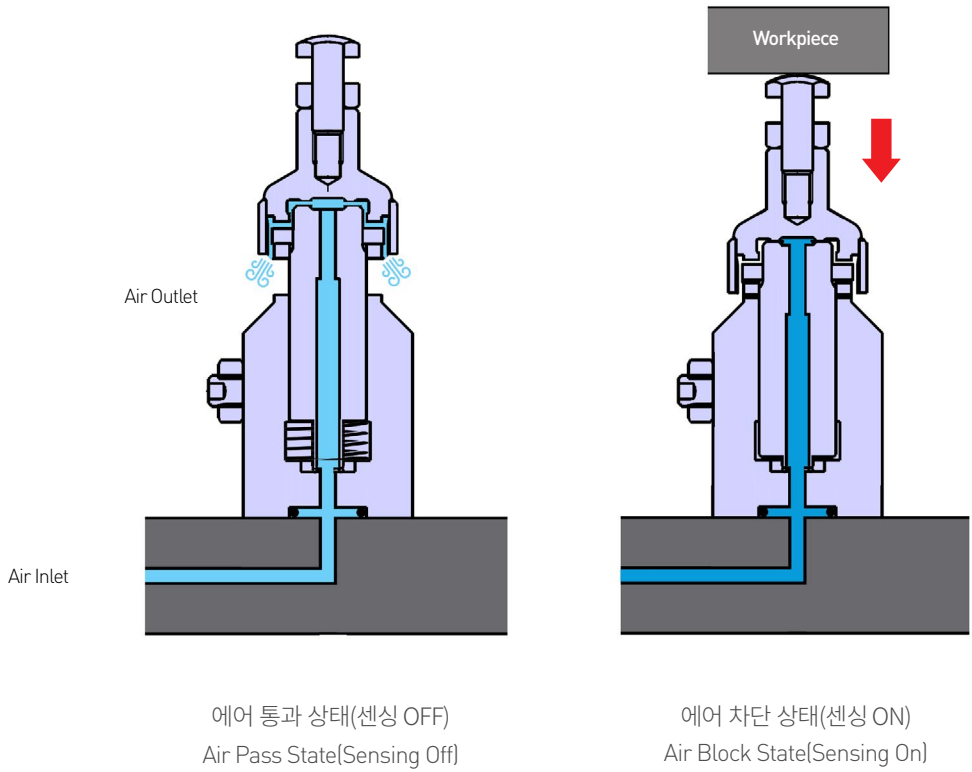

Operation Flow Chart

NEW



에어시팅밸브 Air Seating Valve

Features

- | | |
|-----------------------------------|--|
| 1. 사용 유체: 공압 | 1. Fluid: Pneumatic |
| 2. 에어 착좌 감지용 | 2. For Air Seating Detection |
| 3. 간단한 설치 | 3. Easy Installation |
| 4. 스트로크: 4.5mm | 4. Stroke: 4.5mm |
| 5. 사용압력: 3~9.9kgf/cm ² | 5. Operating Press.: 3~9.9 kgf/cm ² |
| 6. 사용온도: 0~70°C | 6. Operating Temp.: 0~70°C |
| 7. 중량: 131g | 7. Weight: 131g |

> Model No. ASV-10

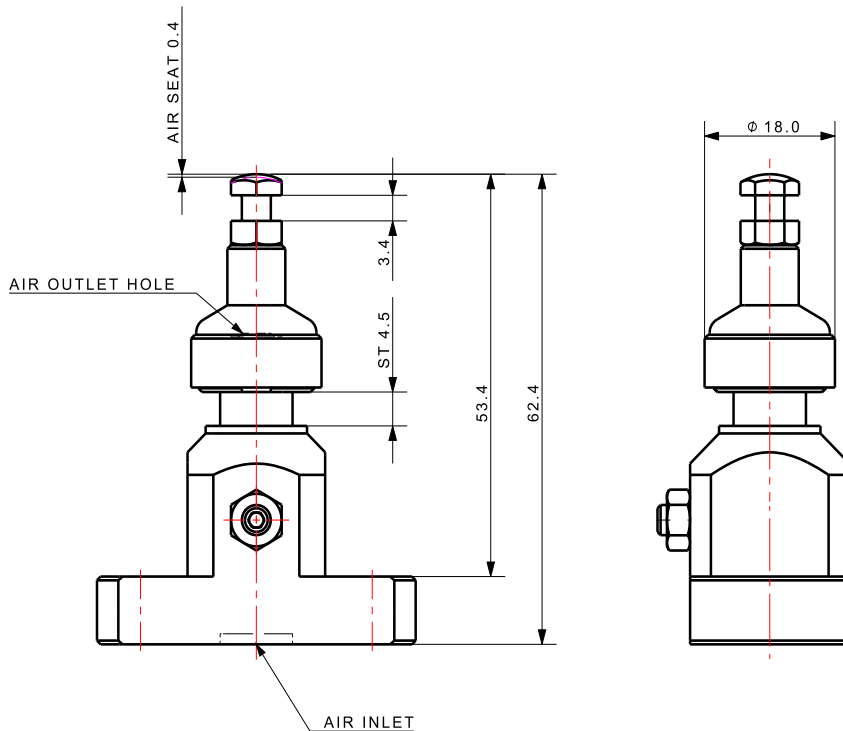
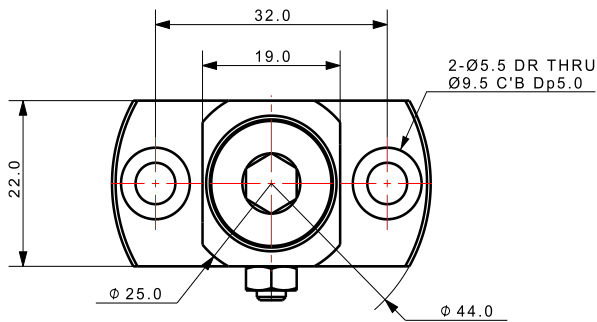

Booster (Air-Hydraulic Power)



Features

1. 저압의 공기압으로 손쉽게 고압의 유압을 얻을 수 있다.
 2. 유압 출력을 이용함에 따라 항상 균등하고 확실한 힘을 얻을 수 있다.
 3. 소형 경량이며 저렴한 가격으로 유압원을 얻을 수 있어 간이 자동화에 쉽게 적용할 수 있다.
1. High oil pressure can be easily obtained with low pneumatic pressure.
 2. Uniform and reliable power can be obtained at all times by using the hydraulic output.
 3. It can be easily applied to simple automation because it is small and light and can obtain hydraulic source at a low price.

Specification

MODEL NO.	Boost Ratio	High Pressure Volume	Operating Air Pressure	Output Pressure	Weight
HBH-1108	11 : 1	80cc	3.2~9.9kgf/cm ²	35~109kgf/cm ²	24.6kg
HBH-1120	11 : 1	200cc		35~109kgf/cm ²	32.0kg
HBH-2212	22 : 1	120cc		70~217kgf/cm ²	32.0kg
HBH-3608	36 : 1	80cc		115~356kgf/cm ²	32.0kg

Dimensions

MODEL NO.	DIMENSIONS (mm)									
	A	B	C	∅D	E	F	G	H	J	K
HBH-1108	272	177	143	70						
HBH-1120	421	254	220	70	220	200	179	255.5	190	100
HBH-2212	473	280	246	55						
HBH-3608										

Installation

1. 부스터는 에어 빼기를 용이하게 하기 위하여 유압 실린더 및 배관보다 높게 설치한다.
 2. 수평위치로 설치하며 특별한 경우에는 수직으로 설치할 수 있다.
 3. 유압배관은 굵고 짧게 한다.
 4. 에어 방향전환 밸브 전에 에어필터, 루브리케이터, 레귤레이터를 설치한다.
1. Booster is installed higher than hydraulic cylinders and piping to facilitate air removal.
 2. The unit should be installed horizontally, but in special cases, it can be installed vertically.
 3. Hydraulic piping should be thick and short.
 4. Air filter, lubricator and regulator should be installed before air direction valve installation.



작동 영상

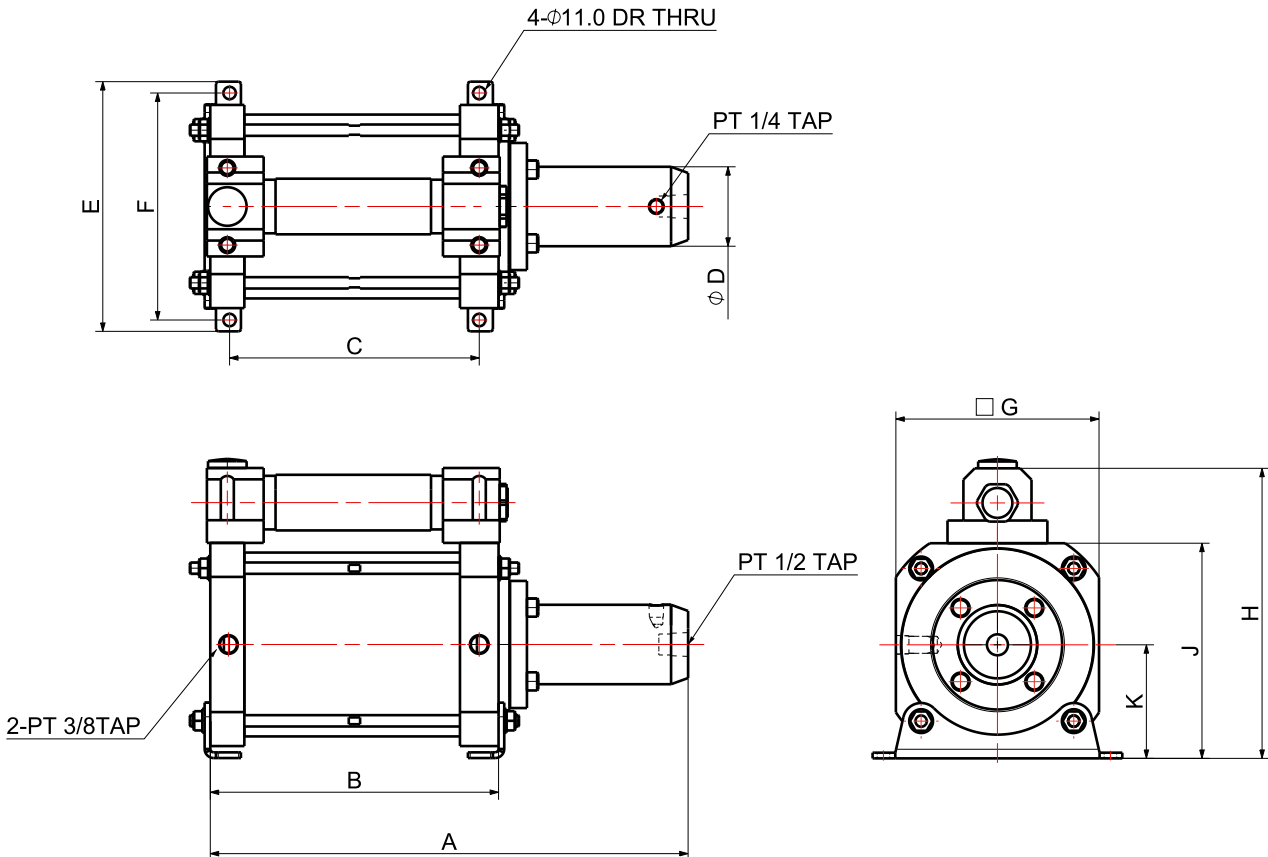

직압식 Direct compressive force

토출량 - 20cc ≥ 필요유량
 Discharge rate - 20cc ≥ needed flux

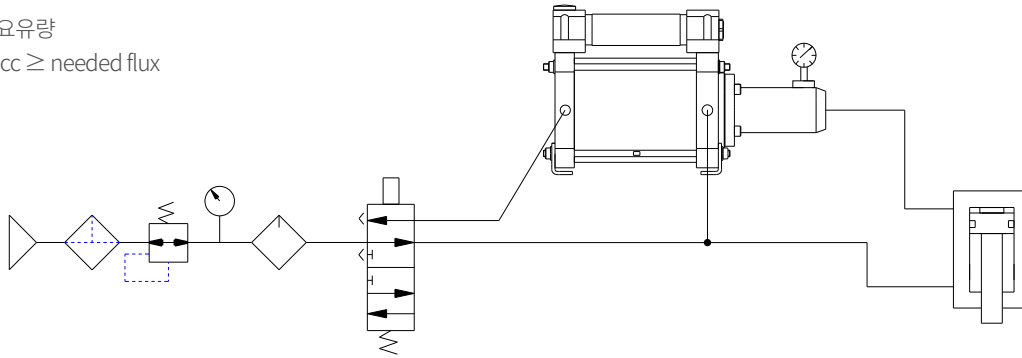

* 단동 실린더는 내경 40파이 이상만 권장합니다.
 A single-acting cylinder is recommended only for bores of 40 mm or larger.

예압식 Pre-compressive force

토출량 - 20cc < 필요유량
 Discharge rate - 20cc < needed flux

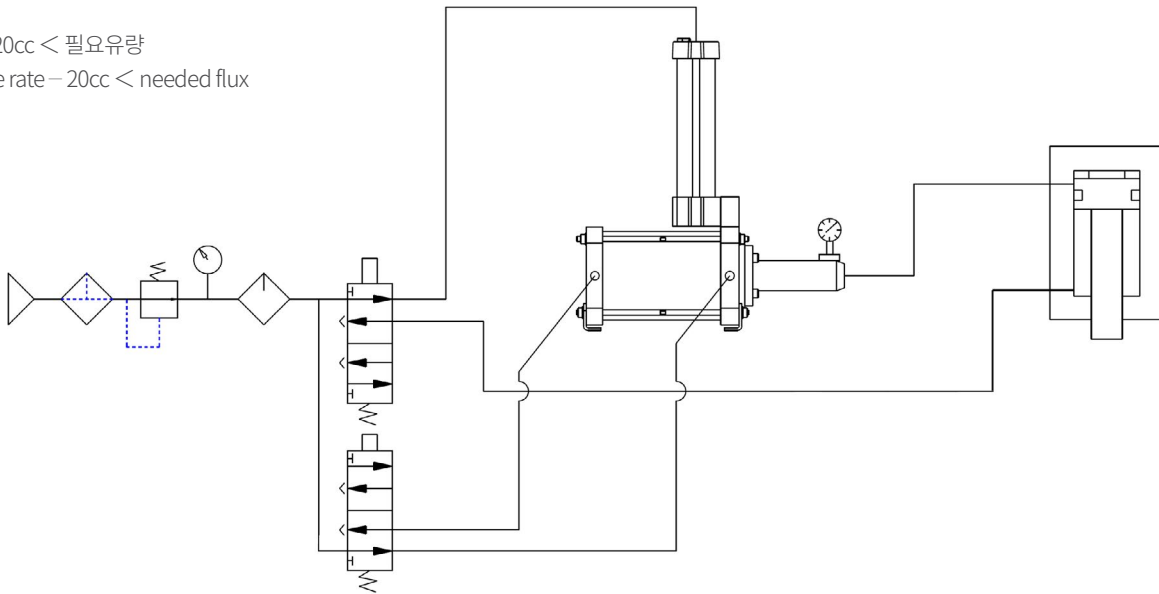

스파크로 인한 우려가 있는 경우에는 타임딜레이밸브 적용방식에 대한 회로도를 문의하십시오.
 In case of a problem caused by a spark, please ask us on the circuit diagram of time delay valve application.

직압식 : Booster가 실린더 보다 낮게 설치된 경우 Direct compressive force : Case of Booster installed lower than cylinder

토출량 - 20cc ≥ 필요유량
 Discharge rate - 20cc ≥ needed flux

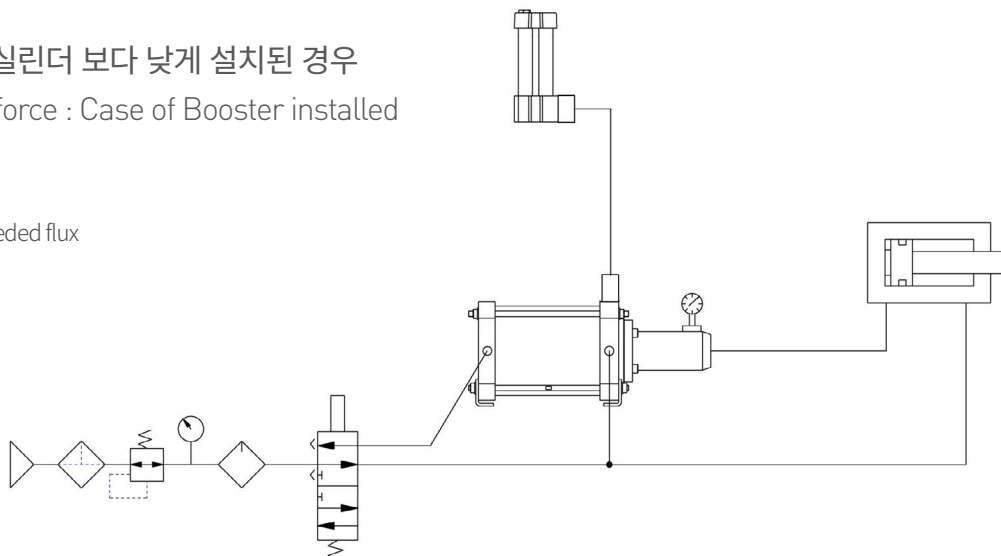

2차 전지 대응 제품들 Products for Secondary Battery

2차 전지 제조공정 조건에 사용할 수 있는 제품들은 불량률을 감소시키고 생산성을 향상시킬 수 있습니다.

동(Cu)
아연(Zn)
제한

저노점
구리스 적용
내구성 향상

공업용제품
라인업
보유

Feature

- **제품에 적용되는 재질을 제한합니다.**
 - 동(Cu), 아연(Zn)을 주성분으로 하는 금속 재질은 사용하지 않습니다.
 - 표면처리에 전해니켈도금, 아연도금을 사용하지 않습니다.
 - 피스톤로드는 경질크롬도금을 처리한 소재를 사용합니다.
- **The materials applied to the product are limited.**
 - Do not use metal materials with copper [Cu] and zinc [Zn] as their main components.
 - Electrolytic nickel plating and zinc plating are not used for surface treatment.
 - Piston rods use materials treated with hard chrome plating.

성분분석기
보유



2차전지 제조공정에 사용할 수 있는 제품들이 다양하게 준비되어 있습니다.
 목차(page 3~4)에 있는 공압제품 라인업 제품들이 대응 가능합니다.

Lineup

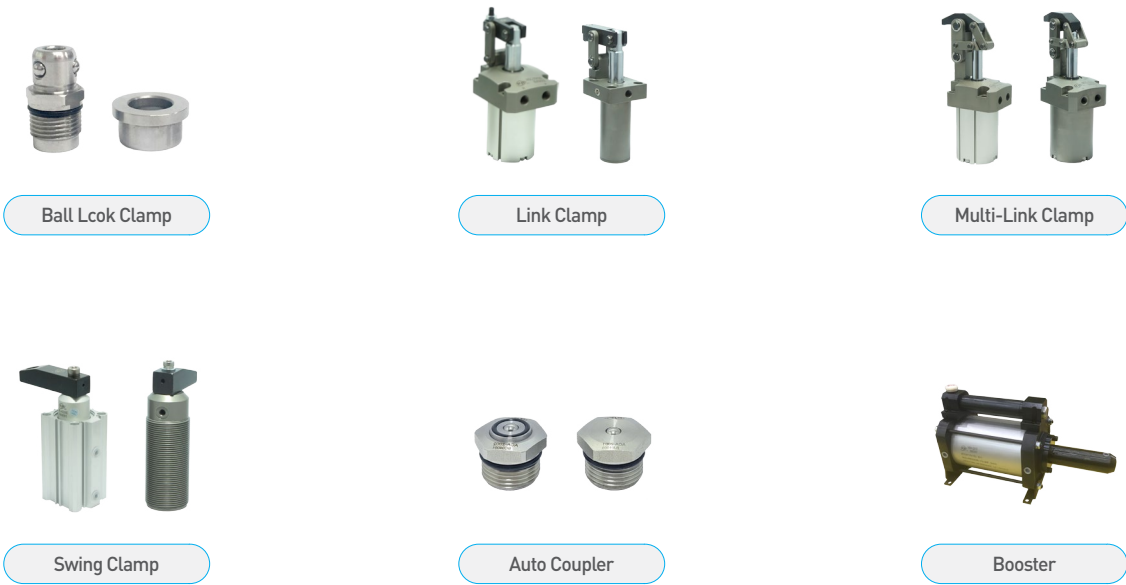

Model No.

EX)

MLC	—	25	47	GV	K	K=2차전지
1		2	3	4	5	

구리/아연이 제한된 재질의 2차 전지용 제품이 필요하시면 견적/주문 시 “2차전지용” 혹은 모델번호 끝자리에 “K”를 표기해 주십시오. 재질을 제외한 모든 사양은 동일함.



유압 제품들

Hydraulic Products



QR코드를 스캔하시면 작동영상을 보실 수 있습니다.
Please scan the QR code for watching operating animation.

초정밀 로케이터 Ultraprecision Locator

초정밀 위치결정, 반복정밀도 3 μ m! Ultraprecision Locating, 3 μ m Repeatability!

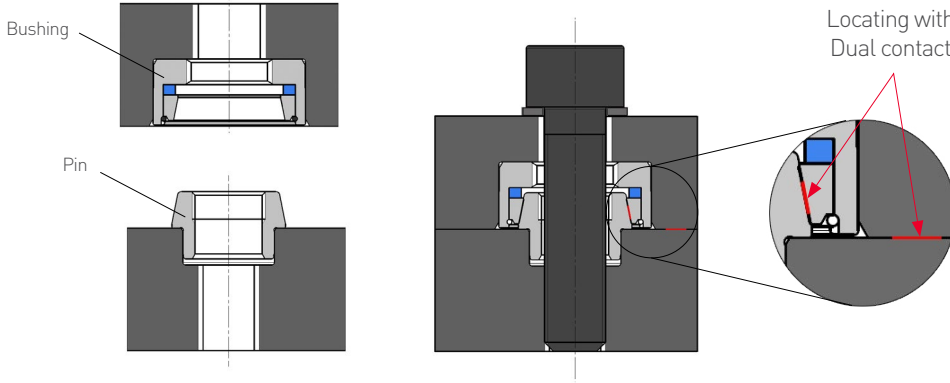

이중 접촉으로 인한 초정밀도로 고품질과 불량률 감소를 실현 시킵니다.

The Ultraprecision by dual contact offers excellent quality and a low percent defective.

Application

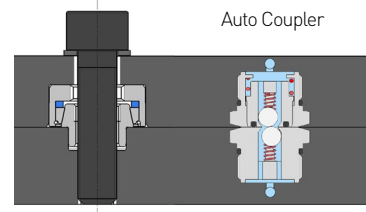
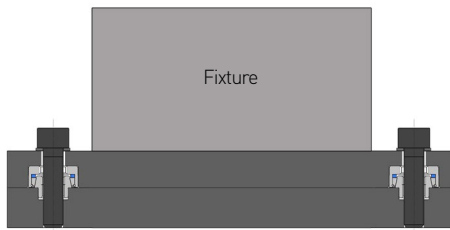

[How to mount and remove]

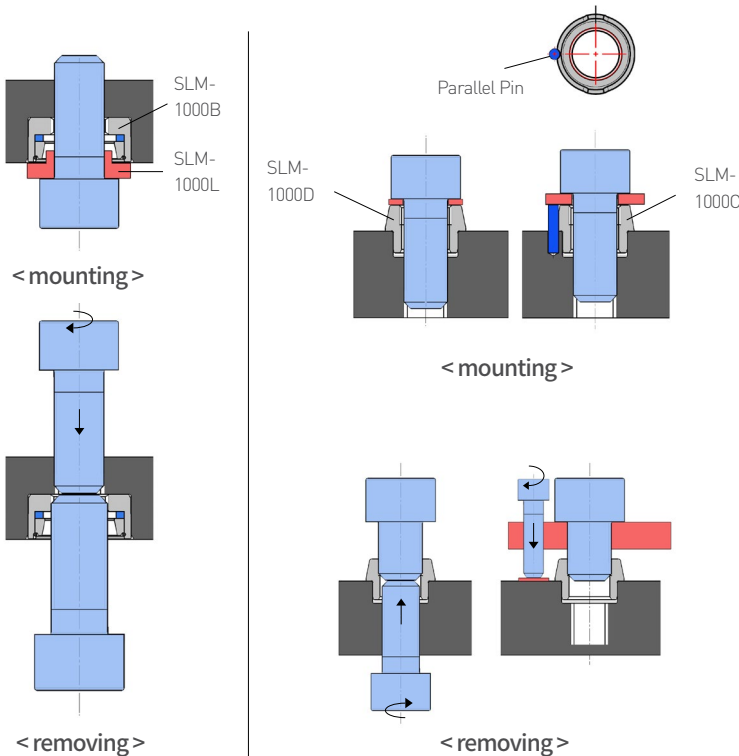

Model No.

- SLM-□00D: Pin
- SLM-□00C: Pin with Notch
- SLM-□00B: Bushing
- SLM-□00L(option): Locating Bushing

Specification

MODEL NO.		SLM - 1000□
Repeatability (mm)		0.003
Stroke (mm)		0.3
Max. Loading Weight (kg)	Horizontal	500
	Vertical	100
Min. Tightening Force (kgf)		203
Operating Temperature (°C)		0~70
Weight (kg)	Pin	0.01
	Bushing	0.024

주의: 핀의 테이퍼 부분을 보호하기 위해 가이드핀을 설치해 주십시오.

Caution: Please install guide pins for protecting the taper part of the pin.

초정밀 로케이터 Ultraprecision Locator



Features

- | | |
|---------------------------|---|
| 1. 간단한 설치 | 1. Simple Installation |
| 2. 반복정밀도: 3 μ m | 2. Repeatability: 3 μ m |
| 3. 컴팩트한 사이즈 | 3. Compact Size |
| 4. 로드중량: Max.~500kg | 4. Load Weight: Max.~500kg |
| 5. 체결력: Min. 203kgf~ | 5. Tightening Force: Min. 203kgf~ |
| 6. 사용온도: 0~70°C | 6. Operating Temperature: 0~70°C |
| 7. 위치결정만 가능
(클램프기능 없음) | 7. Locating function only
(No clamping function) |
| 8. 수동에 의한 위치결정 | 8. Locating by hand |

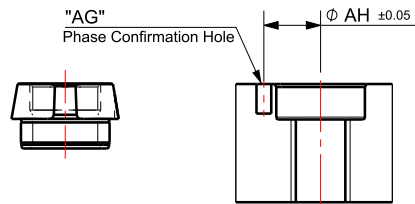
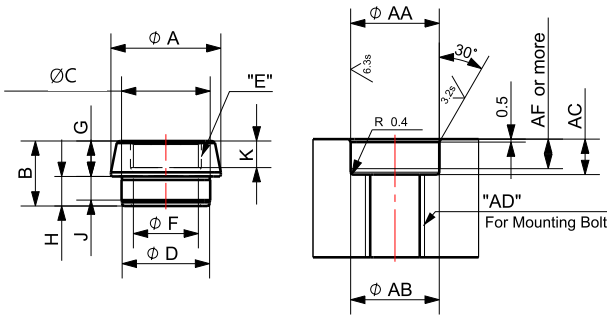
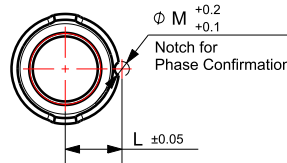
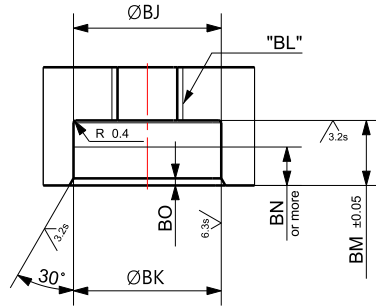
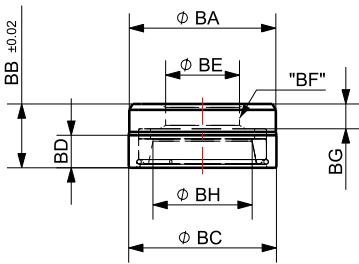

Dimensions

MODEL NO.	SLM-0600□	SLM-0800□	SLM-1000□	SLM-1200□
A	φ12.8	φ14.8	φ18.6	φ22.2
B	8.5	9	11	13
C	φ10.0 +0.024 +0.015	φ12.0 +0.029 +0.018	φ15.0 +0.029 +0.018	φ18.0 +0.029 +0.018
D	φ9.8	φ11.8	φ14.8	φ17.8
E	M8x 1.25P	M10x 1.5P	M12x 1.75P	M16x 2.0P
F	φ6.8	φ8.5	φ11.0	φ14.0
G	4.5	5	6	7
H	4	4	5	6
J	2.9	3.2	4	4.4
K	3.5	3.5	4.5	5.0
L	6.5	7.6	9.6	11.4
M	φ1.5	φ2.0	φ2.5	φ3.0
AA	φ10.0 +0.009	φ12.0 +0.011	φ15.0 +0.011	φ18.0 +0.011
AB	φ10.0 +0.009 -0.1	φ12.0 +0.011 -0.1	φ15.0 +0.011 -0.1	φ18.0 +0.011 -0.1
AC	5.0	5.0	6.0	7.0
AD	M6 x 1.0P	M8 x 1.25P	M10 x 1.5P	M12 x 1.75P
AF	4.0	4.0	5.0	5.5
AG	φ1.50	φ2.0	φ2.5	φ3.0
AH	φ6.5	φ7.6	φ9.6	φ11.4
BA	φ17.8	φ19.8	φ24.8	φ29.8
BB	8.3	8.8	10.8	12.8
BC	φ18.0 +0.033 +0.02	φ20.0 +0.033 +0.02	φ25 +0.033 +0.02	φ30.0 +0.033 +0.02
BD	3.8	4.2	5.5	6.4
BE	φ9.0	φ11.0	φ12.5	φ16.5
BF	M10 x 1.5P	M12 x 1.75P	M14 x 2.0P	M18 x 2.5P
BG	3.2	3.5	4.2	5.2
BH	φ11.6 φ18.0 +0.011 -0.1	φ13.4 φ20.0 +0.013 -0.1	φ16.8 φ25.0 +0.013 -0.1	φ20.3 φ30.0 +0.013 -0.1
BK	φ18.0 +0.011 0	φ20.0 +0.013 0	φ25.0 +0.013 0	φ30.0 +0.013 0
BL	M8x 1.25P	M10x 1.5P	M12x 1.75P	M16x 2.0P
BM	8.5	9.0	11.0	13.0
BN	5.0	5.5	6.5	7.5
BO	0.8	1.0	1.2	1.5

[Note to mount Pin and Bushing]

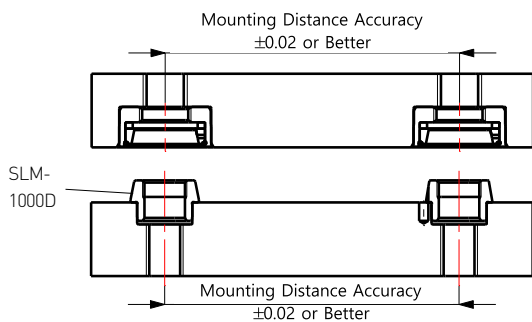

D type과 C type 핀들을 1세트만 설치하면 위치 결정이 됩니다. 볼트를 4개 이상 사용하여 상하판을 고정할 경우에는 핀들을 대각선으로 설치 하십시오.

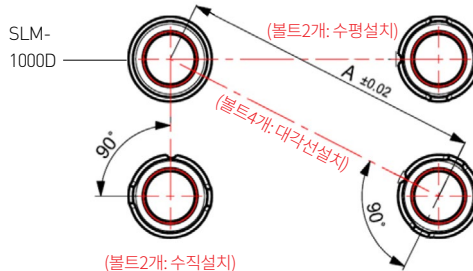

SLM-1000D센터와 SLM-1000C 홈은 90°로 정렬.
Align SLM-1000D center and SLM-1000C notch as 90°.

핀과 부싱을 결합할 때 볼트조임 순서는 SLM-1000D가 먼저입니다.
Tight bolt SLM-1000D first when pins and bushings are assembled.

Work Support Applications

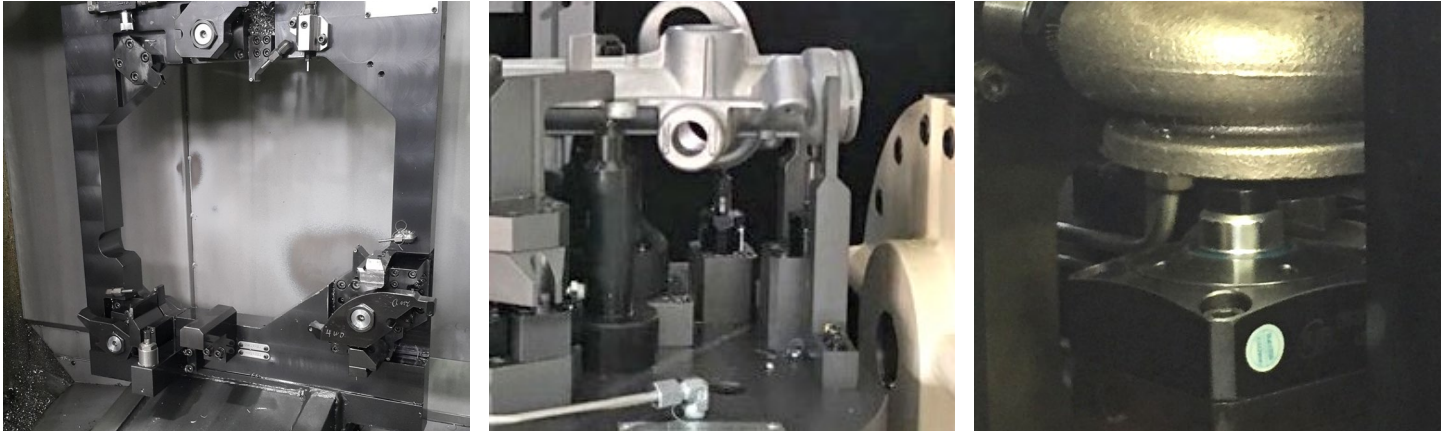

Work Support Line Up



Built-In Work Support



Flange Work Support



Block Work Support



Work Support Introduction

워크서포트는 가공부하로 인한 공작물의 처짐 또는 떨림을 해결하는 도구입니다. 워크서포트를 사용했을 때, 공작물의 가공정밀도 유지와 공구 떨림을 줄여서 공구의 수명을 연장할 수 있습니다.

Work Support prevents chatter and deformation caused by cutting load during machining workpiece. Since it maintains machining accuracy of workpiece and reduces tool vibration, tool life is extended.

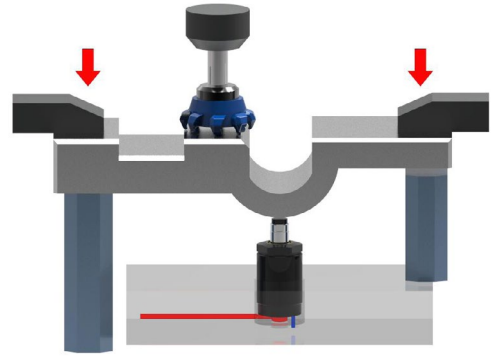

Action Description

Spring Advance (1단)

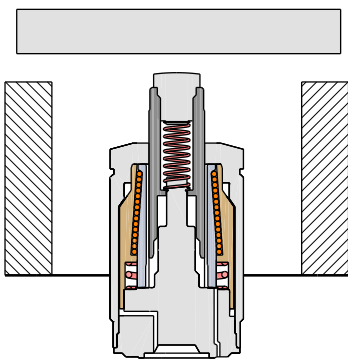

Hydraulic Pressure : Off

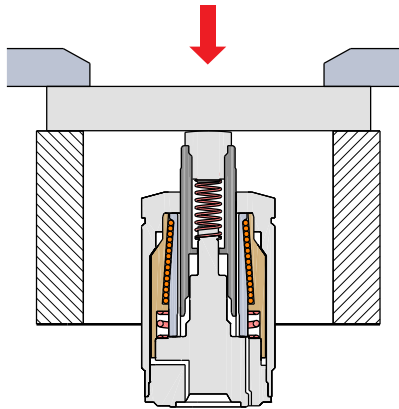

Hydraulic Pressure : Off

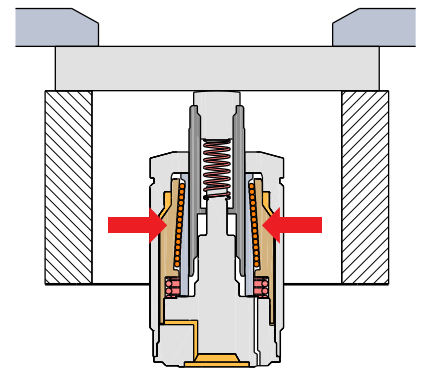

Hydraulic Pressure : On

Hydraulic Advance (2단)

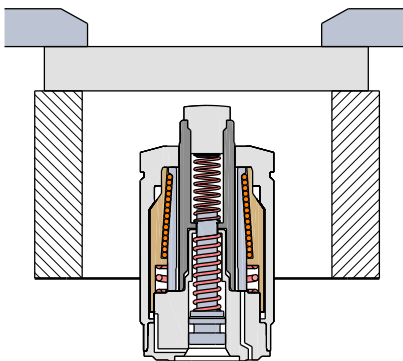

Hydraulic Pressure : Off

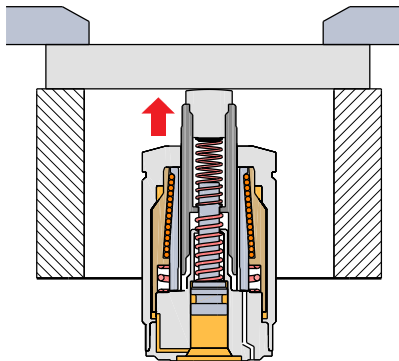

Hydraulic Pressure : On

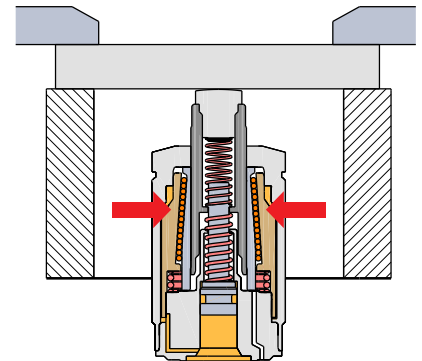

Hydraulic Pressure : On

Work Support Applications

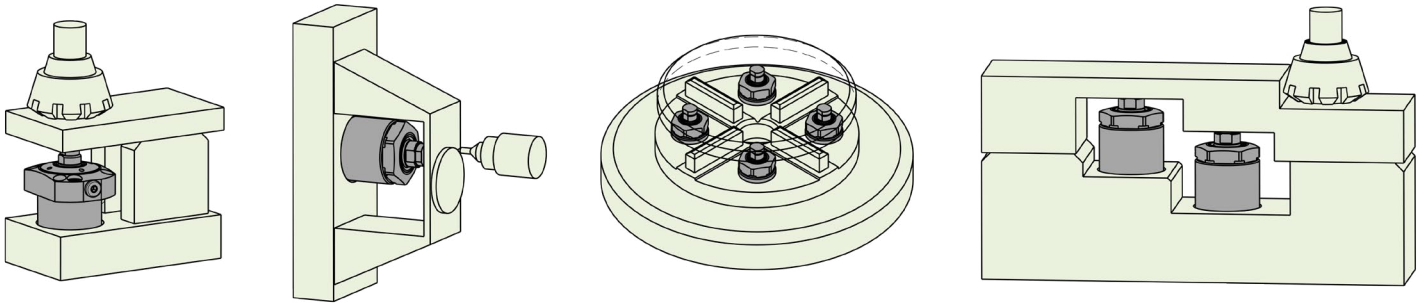

Model No.

CWS-20122FG-H



1 CWS = Work Support

3 Stroke
ex) 12 = 12mm

2 Plunger Diameter
ex) 20 = $\varnothing 20$

4 Action Type
ex) 1 = Spring Advance
2 = Hydraulic Advance

5 Mounting Type
No sign = Built-In Type
FG = Flange Gasket Type

6 Plunger Spring
H = High Force
L = Low Force

★ Air Purge Function

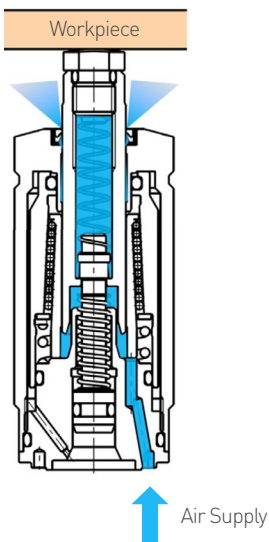

주의사항 Note

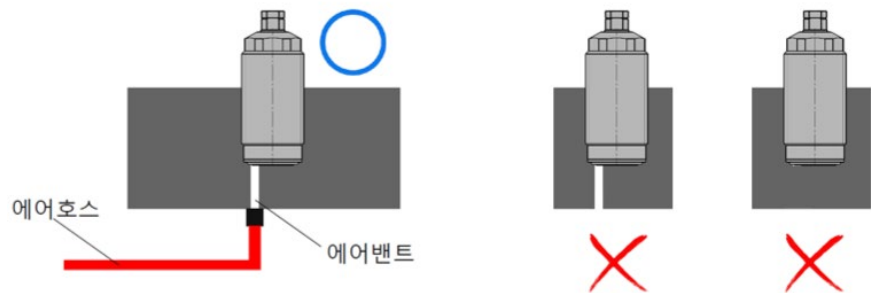

1. 원활한 동작을 위해 에어벤트를 이물질이 침입하지 않는 범위에서 대기중으로 개방시켜야 합니다.
2. 회로구성은 반드시 클램프실린더와 워크써포트를 별개로 구성해야 합니다.
3. 2단 워크써포트는 반드시 스피드컨트롤밸브를 메타인으로 설치할 것을 강력 추천합니다.
4. 패드 제작시, 플런저 내부에 이물질이 들어가지 않도록 제공하는 도면에 의해 패드제작을 해 주십시오.

1. To ensure proper operation, the air vent must be opened to the atmosphere with preventing foreign matter from entering.
2. The circuit of clamp cylinder and work support must have a separate line.
3. Speed control valve(meter-in) have to be installed for hydraulic advance type of work support.
4. Please make and assemble pad without entering foreign matter into plunger.

Specification

Work Support Built-In Type

MODEL NO.	CWS-12081-□	CWS-12082-□	CWS-15081-□	CWS-15082-□
Operation Method	Spring Advance	Hydraulic Advance	Spring Advance	Hydraulic Advance
Support Force(kgf) at 70kgf/cm ²	285	285	392	392
Plunger Stroke (mm)	8	8	8	8
Plunger Diameter (Ø)	12	12	15	15
Oil Capacity(cm ³)	0.5	0.9	0.6	1.3
Plunger Spring Froce (kgf)	0.2-0.4(Low), 0.3-0.5(High)		0.48-0.88(Low), 0.65-1.08(High)	
Operating Pressure Range	25 - 70 kgf/cm ²			
Operating Temperature Range	0-70°C			
Weight (kg)	0.28	0.27	0.38	0.37

Work Support Flange Type

MODEL NO.	CWS-20121FG-□	CWS-20122FG-□
Operation Method	Spring Advance	Hydraulic Advance
Support Force(kgf) at 70kgf/cm ²	1106	1106
Plunger Stroke (mm)	12	12
Plunger Diameter (Ø)	20	20
Oil Capacity(cm ³)	2.0	3.3
Plunger Spring Froce (kgf)	0.82-1.54(low), 1.42-2.37(high)	
Operating Pressure Range	25 - 70 kgf/cm ²	
Operating Temperature Range	0-70°C	
Weight (kg)	1.34	1.30

Circuit Diagram

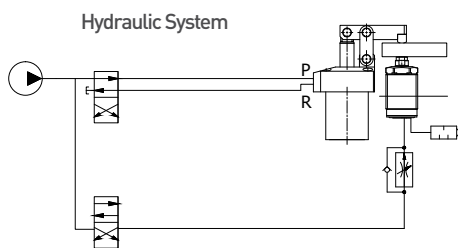

SOL Valve + Work Support

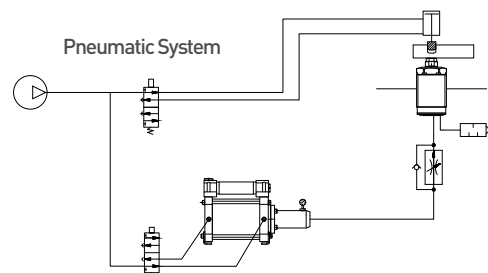

Booster + Work Support

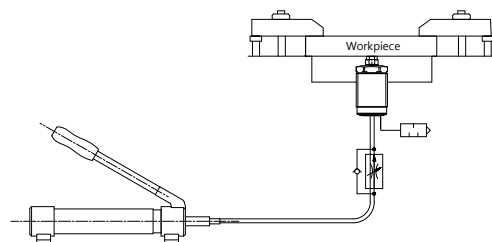

Hand Pump + Work Support

- * 2단은 Flow Control Valve 사용 권장.
- * Using Flow Control Valve recommended for Hydraulic Advance.

Low Pressure Work Support Built-In Type



1단
Spring Advance



2단
Hydraulic Advance

Features

- | | |
|--|---|
| 1. 강력한 써포팅 | 1. Strong supporting |
| 2. 가스연질화 표면처리 | 2. Gas Nitriding Surface |
| 3. 1단 & 2단 작동방식 | 3. Spring/Hydraulic advance |
| 4. 사용압력 : 25~70kgf/cm ² | 4. Operating Pressure : 25~70kgf/cm ² |
| 5. 사용온도 : 0~70°C | 5. Operating Temperature : 0~70°C |
| 6. 본체 권장체결토크
CWS-12081/2 : 510 kgf·cm (50 N·m)
CWS-15081/2 : 612 kgf·cm (60 N·m) | 6. Recommended tightening torque for body
CWS-12081/2 : 510 kgf·cm (50 N·m)
CWS-15081/2 : 612 kgf·cm (60 N·m) |
| 7. 과도한 힘으로 결합시
불량의 원인이 됨. | 7. Assembly with excessive force
will cause defect. |

> CWS - 12 08 1 H

① ② ③ ④

- ① Plunger Diameter(mm) ② Stroke(mm) ③ Operating Method
④ Plunger Spring Force

Dimensions

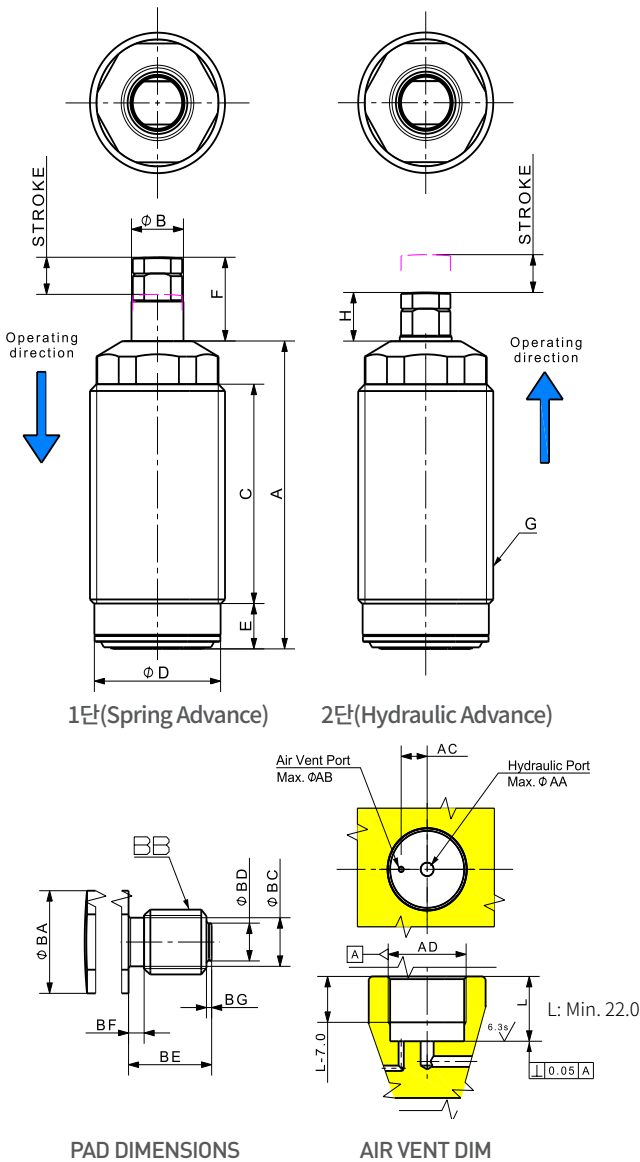

MODEL NO.	CWS-1208x	CWS-1508x
A	62.0	58.0
φB	12.0	15.0
C	42.3	39.7
φD	28.2	34.3
E	11.4	9.8
F	19.0	19.0
G	M30 x 1.5P	M36 x 1.5P
H	11.0	11.0
φAA	5.0	6.0
φAB	2.5	3.0
AC	10.0	12.0
AD	M30 x 1.5P	M36 x 1.5P
φBA	11.5	12.5
BB	M8 x 1.25P	M10 x 1.5P
φBC	6.0	8.2
φBD	4.6	6.0
BE	10.0	10.0
BF	2.3	2.0
BG	1.5	1.0



1단(Spring Advance)



2단(Hydraulic Advance)

Low Pressure Work Support Flange Type

Features

1. 강력한 써포팅
 2. 가스연질화 표면처리
 3. 1단&2단 작동방식
 4. 사용압력 : 25~70kgf/cm²
 5. 사용온도 : 0~70°C
1. Strong supporting
 2. Gas Nitriding Surface
 3. Spring/Hydraulic Advance
 4. Operating Pressure : 25~70kgf/cm²
 5. Operating Temperature : 0~70°C

> CWS-20 12 2 FG H
① ② ③ ④ ⑤

- ① Plunger Diameter(mm) ② Stroke(mm) ③ Operating Method
④ Flange Gasket Type ⑤ Plunger Spring Force

> CWS-20121FG
: 1단(Spring Advance)

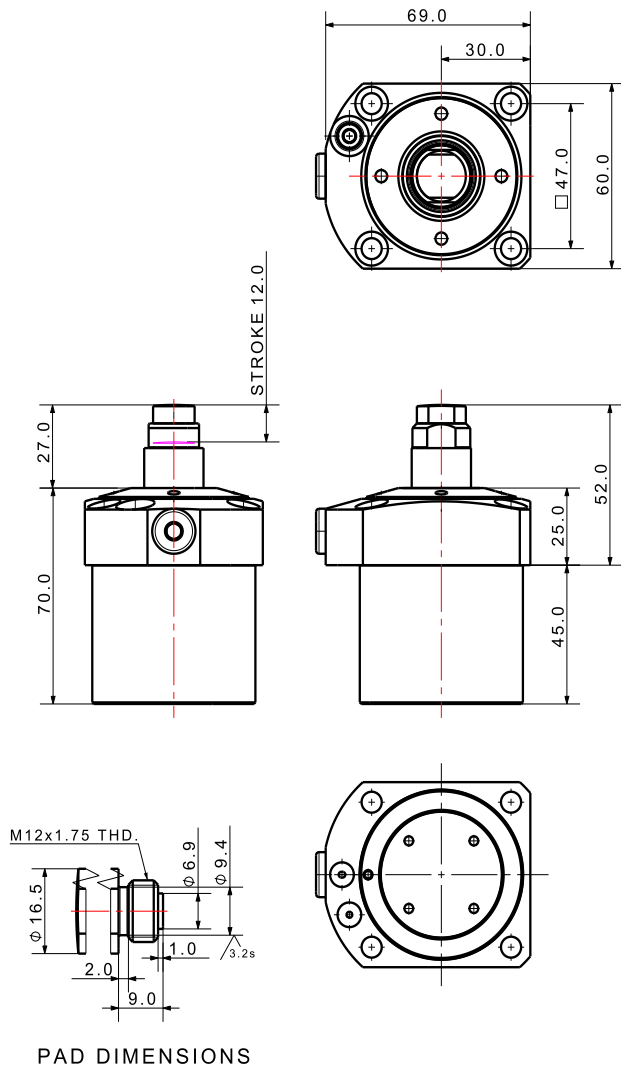

> CWS-20122FG
: 2단(Hydraulic Advance)

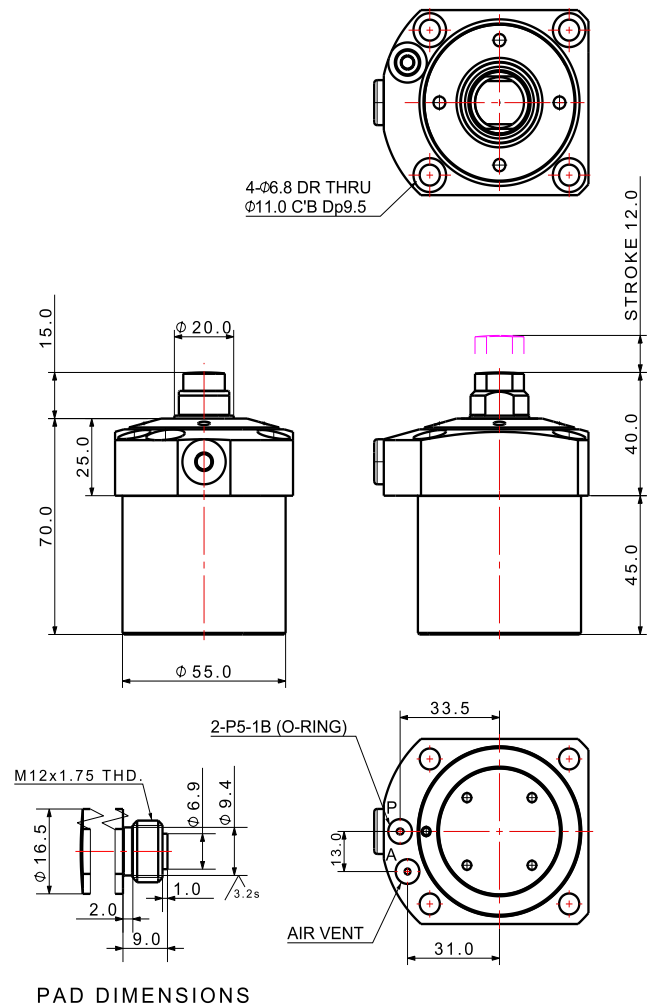

> CWD-4010



> CWD-4011



Work Support Block Type

Features

- | | |
|------------------------------------|--|
| 1. 작동압력 : 5~100kgf/cm ² | 1. Operating Pressure : 5~100kgf/cm ² |
| 2. 피스톤속도 : 8~100mm/s | 2. Piston Speed : 8~100mm/s |
| 3. 사용온도범위 : 0~60°C | 3. Operating Temperature : 0~60°C |
| 4. Seal 재료 : 니트릴고무, 폴리우레탄 | 4. Seal Material : Nitrile rubber, Polyurethane |

> CWD-4010과 CWD-4011은 대칭으로 제작된 것이다.

> CWD-4010 and CWD-4011 are symmetry design.

> CWD-40 10 ① Piston Diameter
CWD-40 11 ①
①

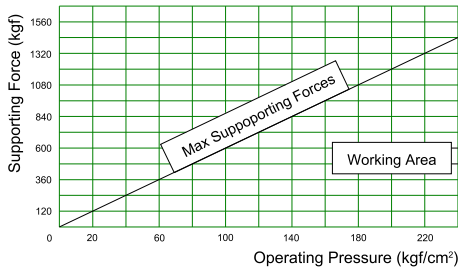

Specification

MODEL NO.	Effective Area(cm ²)		Oil Capacity(cm ³)		Operating Pressure (kgf/cm ²)	Weight (kg)	Spring Force(kgf)	Stroke (mm)
	Push	Pull	Push	Pull				
CWD-4010	12.56	9.42	18.84	14.13	5~100	3.2	1.7	10
CWD-4011								

> CWD - 4010

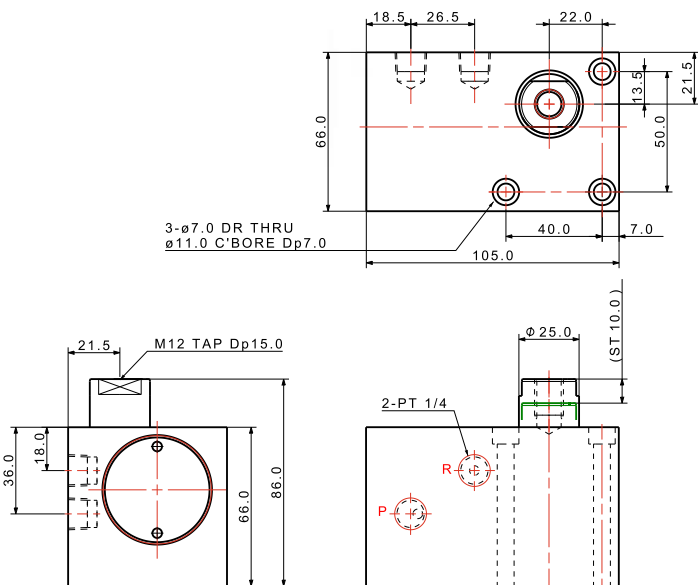

> CWD - 4011

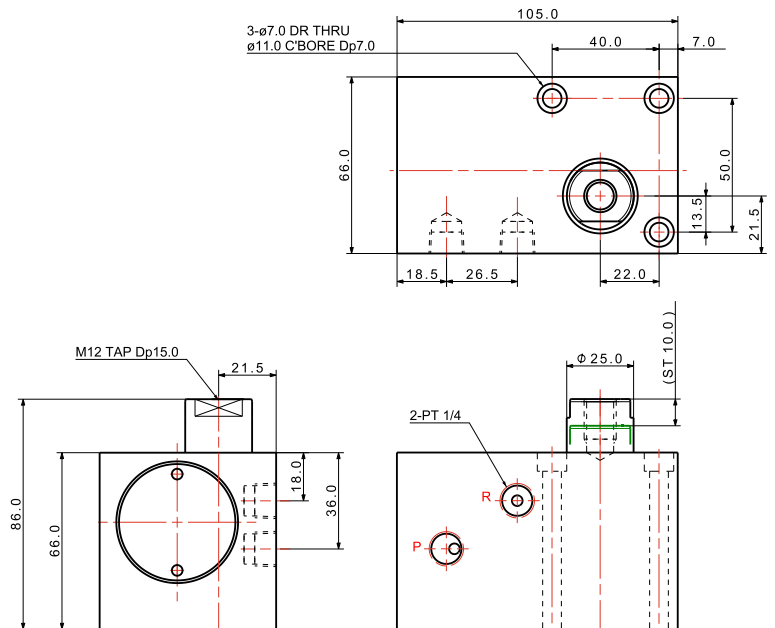

Work Support Bracket

> CWB-2637

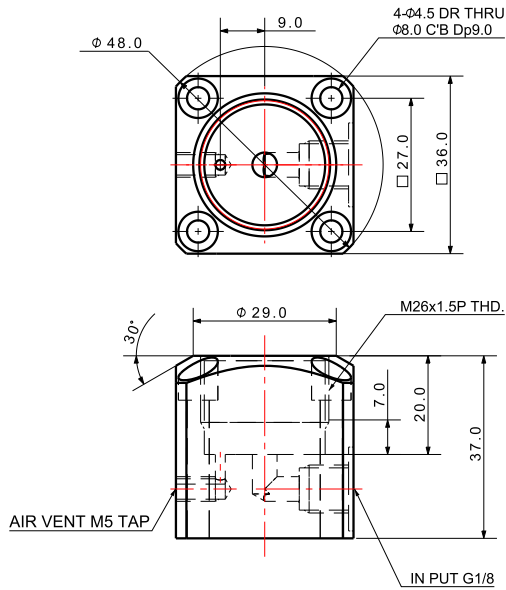

> CWB-3045

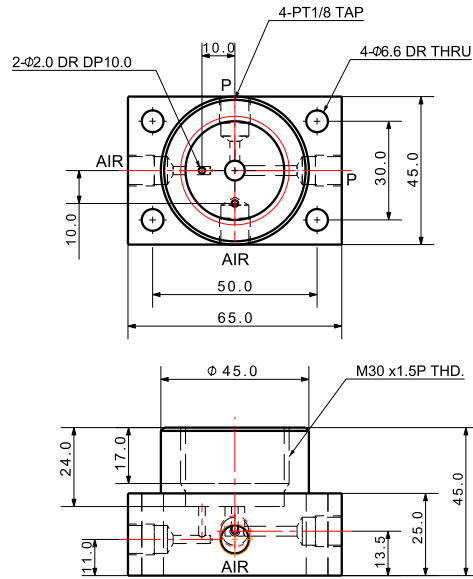

> CWB-3640

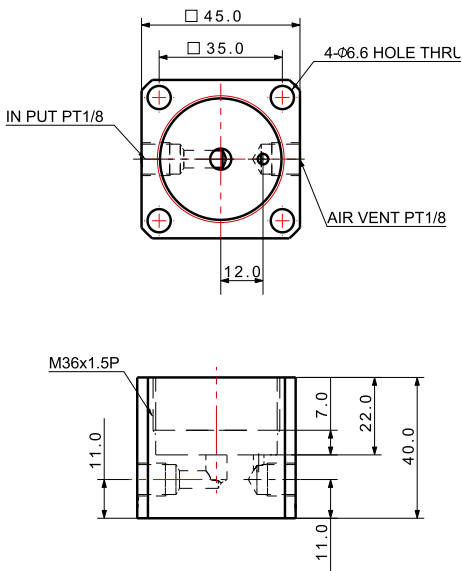

> T Type

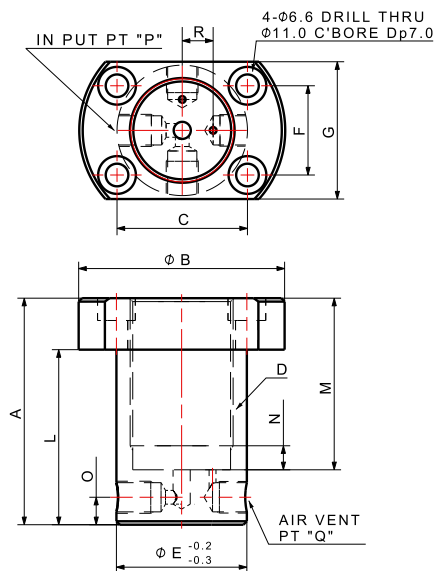

Dimensions

MODEL NO.	CWB-2660	CWB-3066	CWB-3663
A	60.0	66.0	63.0
ϕB	$\phi 54.0$	$\phi 60.0$	$\phi 66.0$
C	31.0	38.0	42.0
D	M26 x 1.5P	M30 x 1.5P	M36 x 1.5P
ϕE	$\phi 34.0$	$\phi 38.0$	$\phi 43.0$
F	25.0	26.0	30.0
G	40.0	40.0	46.0
ϕH	$\phi 6.6$	$\phi 6.6$	$\phi 6.6$
ϕJ	$\phi 11.0$	$\phi 11.0$	$\phi 11.0$
K	7.0	7.0	7.0
L	45.0	51.0	48.0
M	43.0	50.0	47.0
N	7.0	7.0	7.0
O	8.0	8.0	8.0
P	PT1/8	PT1/8	PT1/8
Q	PT1/8	PT1/8	PT1/8
R	9.0	10.0	12.0

Multi-Link Clamp Gasket Type (Low Pressure)

간섭을 피해 클램핑!! Clamping to avoid interference!!

Application

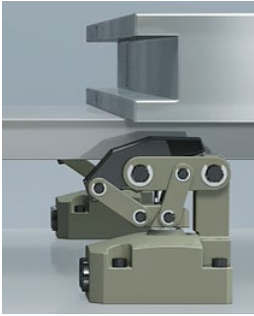

언클램프 상태
(상부 간섭 회피)

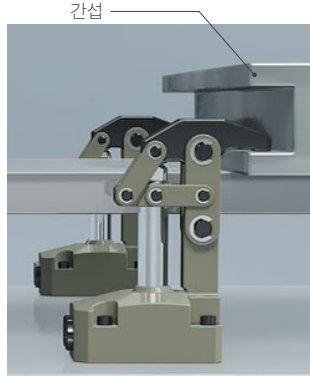

클램프 상태
(간섭 피해 클램프)

Manifold Method

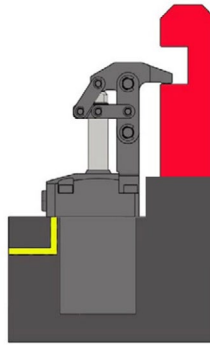

Operation



Model No.

MLC-2547GV

MLC	-	25	47	GV
1		2	3	4

1 Clamp Type
MLC = Multi-Link Clamp

2 Piston Diameter
ex) 25 = ø25

3 Housing Diameter
ex) 47 = ø47

4 Type
> G = Gasket
> GV = Gasket + Flow control valve, Meter-in method
* V: meter-in valve W: meter-out valve



작동 영상

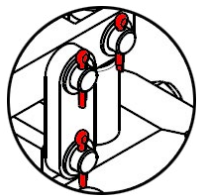

* 분할 핀 사양
Split pin

분할핀 사양은 주문제작으로 가능합니다.
The specifications of the split pin can be custom-made.



Multi-Link Clamp Gasket Type

Features

- | | |
|--|---|
| 1. 간섭을 피해 클램프 | 1. Clamping to avoid interference |
| 2. 유압으로 작동 | 2. Operating with hydraulic system |
| 3. 가스연질화 표면처리 | 3. Gas Nitriding Surface |
| 4. 내경범위: ø25~50 | 4. Piston Diameter: ø25~50 |
| 5. 작동압력: 15~70(유압) kgf/cm ² | 5. Operating Pressure: 15~70(Oil) kgf/cm ² |
| 6. 사용온도: 0~60°C | 6. Operating Temperature: 0~60°C |
| 7. 레버는 옵션 | 7. Lever is option item |

> MLC-25 47 G

① ② ③

① Piston Diameter(mm) ② Housing Diameter(mm)

③ Gasket Type, Gasket Side Valve Type

MLC-25 47 GV

① ② ③

Specification

Model No.	Clamping Force(kgf)	Piston Diameter(Ø)	Effective Area(cm ²)	Stroke(mm)			Oil Capacity (cm ³)		Operating Pressure Range (kgf/cm ²)	Operating Temperature Range(°C)	Weight(kg)
	@70kgf/cm ²			Total	Clamp	Extra	Clamp (Push)	Unclamp (Pull)			
MLC-2038G	179	20	3.14	25.0	22.5	2.5	8.6	7.9	15~70 (Hydraulic)	0~60	0.86
MLC-2547G	283	25	4.9	31.5	29	2.5	15.4	8.5			1.51
MLC-3255G	430	32	8.04	35.5	33	2.5	28.5	23.2			2.22
MLC-4065G	691	40	12.56	41.0	38	3.0	51.5	43.3			3.68
MLC-5080G	1,112	50	19.63	47.0	44	3.0	92.3	77.7			5.86

Clamping Force Calculation Formula

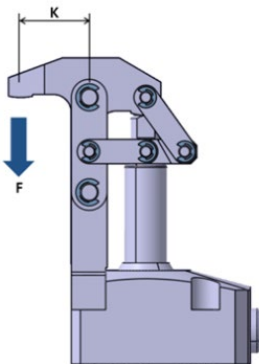

Hydraulic Clamp

클램핑력은 치수 K와 사용압력에 따라 변합니다.
아래의 계산식을 통해 클램핑력을 구해 주십시오.

Clamping force varies depending on dimension K and operating pressure.
Use below formula to calculate clamping force.

- > F = Clamping Force(kgf)
- > P = Hydraulic Pressure(kgf/cm²)
- > K = 옆의 도면 참조 Refer to Drawing (mm)

GASKET

- MLC-2038G : F = 54.9 x P/K
- MLC-2547G : F = 93.1 x P/K
- MLC-3255G : F = 172.0 x P/K
- MLC-4065G : F = 306.2 x P/K
- MLC-5080G : F = 588.0 x P/K

* K 치수: 카탈로그 치수의 30% 이상 커지는 것은 권장 안함.
K Dimension: It is not recommended to exceed 30% of the catalog dimension.

Drawing

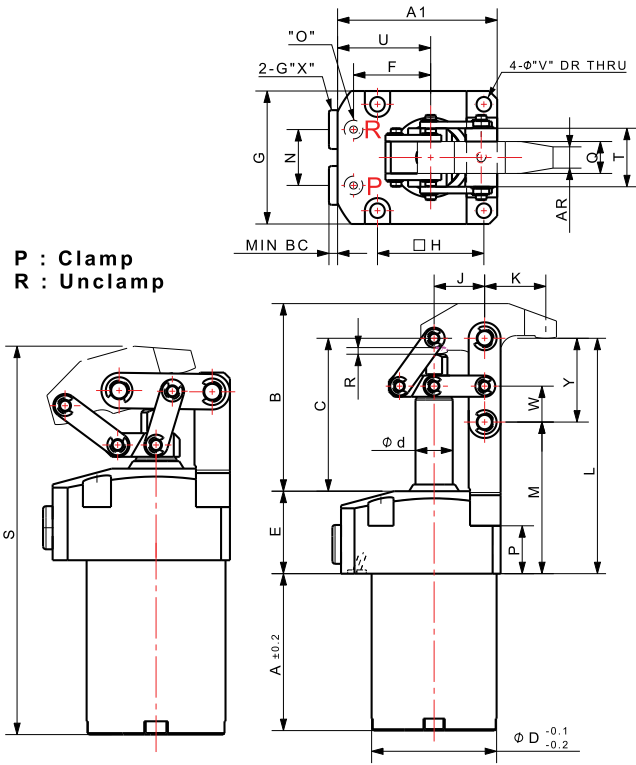

Dimensions

MODEL NO.	MLC-2038G	MLC-2547G	MLC-3255G	MLC-4065G	MLC-5080G
A	48.0	59.0	70.0	79.0	86.0
A1	51.0	60.0	67.0	80.0	93.0
B	59.5	70.5	79.5	98.0	111.0
C	46.5	57.5	64.5	80.0	89.0
øD	38.0	47.0	55.0	65.0	80.0
ød	10.0	14.0	14.0	16.0	20.0
E	25.0	31.0	31.0	38.0	44.0
F	22.5	29.0	32.0	37.0	44.0
G	41.0	50.0	59.0	69.0	84.0
H	33.0	40.0	47.0	55.0	67.0
J	17.5	19.0	21.5	24.5	30.0
K	21.5	23.0	28.0	31.0	37.0
L	71.5	88.5	95.5	118.0	133.0
M	45.5	57.0	60.5	72.5	83.0
N	17.0	21.0	21.0	25.0	28.0
O	P5	P6	P6	P6	P6
P	15.0	18.0	17.0	21	23.0
Q	10.0	12.0	16.0	19.0	22.0
R	2.5	2.5	2.5	3.0	3.0
S	107.5	131.4	148.2	171.4	193.5
T	19.0	22.0	28.0	36.0	42.0
U	28.0	35.0	37.5	45.5	51.0
V	4.5	5.5	6.6	9.0	11.0
W	10.0	13.5	15.0	17.5	19.0
X	G1/8	G1/8	G1/8	G1/4	G1/4
Y	26.0	31.5	35.0	45.5	50

GV Type

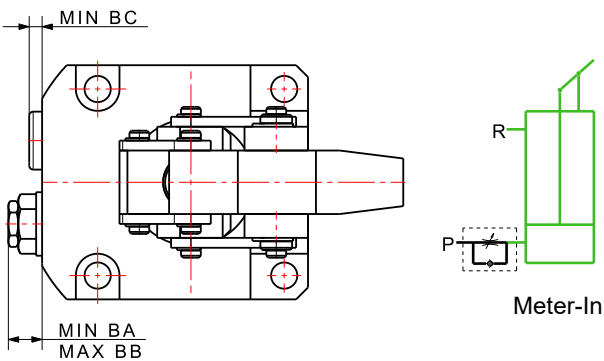

Dimensions

MODEL NO.	MLC-2038G	MLC-2547G	MLC-3255G	MLC-4065G	MLC-5080G
BA	8	8.5	8.5	12	12
BB	12	12.5	12.5	16	16
BC	2.8	3.25	3.25	4.5	4.5

Clampable Dimension for Interference Part

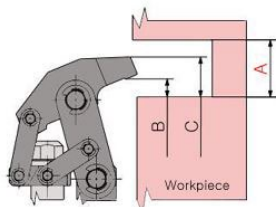

* A : minimum dimension

Model NO.	MLC-2038	MLC-2547	MLC-3255	MLC-4065	MLC-5080
A	18	20	25	29	35
B	5.4	6.34	8.61	9.29	11.1
C	14	15	17.9	20	24.5
stroke @ "C"	15	20	22	26	30

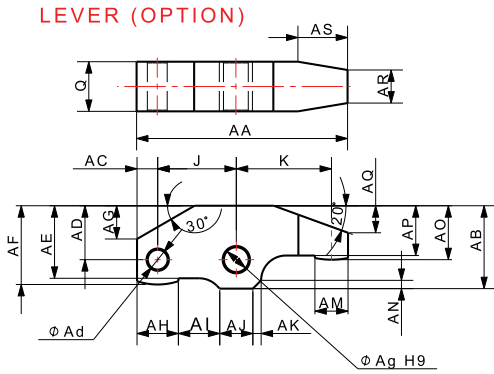

Dimensions

MODEL NO.	MLC-2038G	MLC-2547G	MLC-3255G	MLC-4065G	MLC-5080G
AA	47.5	51.0	59.0	66.5	78.0
AB	20.0	20.0	23.0	28.0	34.0
AC	4.5	5.0	5.5	7.0	7.0
AD	13.0	13.0	15.0	18.0	22.0
ϕAd	4.8	4.8	5.8	6.8	6.8
ϕAg	5.0	6.0	8.0	10.0	12.0
AE	17.5	17.5	19.5	24.5	29.0
AF	19.0	19.0	21.0	26.0	32.0
AG	8.0	8.0	10.0	14.0	16.0
AH	11.0	10.0	11.0	14.0	14.0
AI	7.0	10.0	11.0	12.5	16.0
AJ	8.0	8.0	8.0	10.0	12.0
AK	2.0	2.0	5.0	5.0	7.0
AM	8.0	8.0	8.0	8.0	8.0
AN	2.0	2.0	3.0	5.0	5.0
AO	13.0	13.0	15.0	18.0	22.0
AP	12.0	12.0	14.0	17.0	21.0
AQ	6.5	6.5	8.0	9.5	10.6
AR	6.0	8.0	12.0	14.0	16.0
AS	12.0	12.0	16.0	17.0	20.0

Mounting Detail

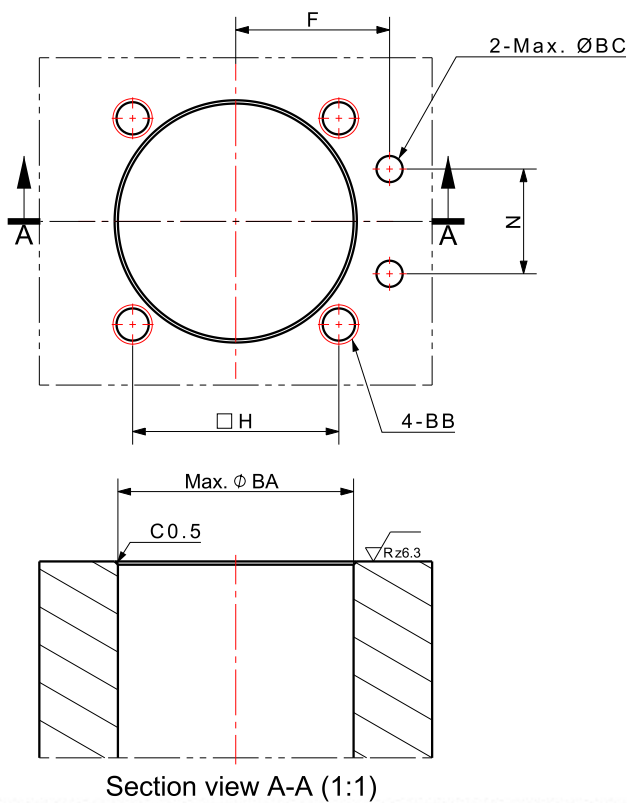

Dimensions

MODEL NO.	F	H	N	ØBA	BB	ØBC
MLC-2547G	29.0	40.0	21.0	48	M5	5.0
MLC-3255G	32.0	47.0	21.0	56	M6	5.0
MLC-4065G	37.0	55.0	25.0	66	M8	5.0
MLC-5080G	44.0	67.0	28.0	81	M10	5.0

Hinge(Link) Clamp Introduction

힌지 클램프는 링크와 핀을 활용해 디자인한 제품으로 공작물을 로딩 / 언로딩할 때 간섭이 없는 충분한 언클램프 각도와 컴팩트한 사이즈는 설계자의 설계 편의성을 최대로 고려한 디자인입니다. 힌지점과 몸체가 일체형으로 매우 견고한 구조이고 내구성도 우수합니다. 설치 상황에 가장 적합한 제품을 선정할 수 있도록 다양한 타입과 사이즈가 있습니다.

Hinge(Link) Clamp is a product designed using link and pin. Designed with sufficient unclamp angle and compact size, there is no interference when loading and unloading workpiece, which maximizes designer convenience. The body, integral with hinge point, provides very strong structure and durability. The products are available in various types and sizes to suit your installation environment.

Installation

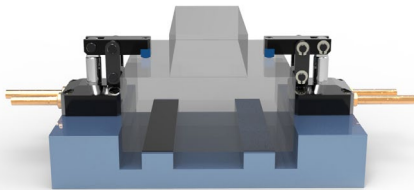

Lever Operation

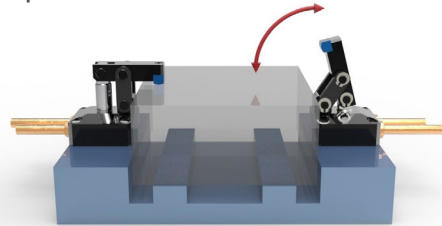

Structure



Caution on Lever

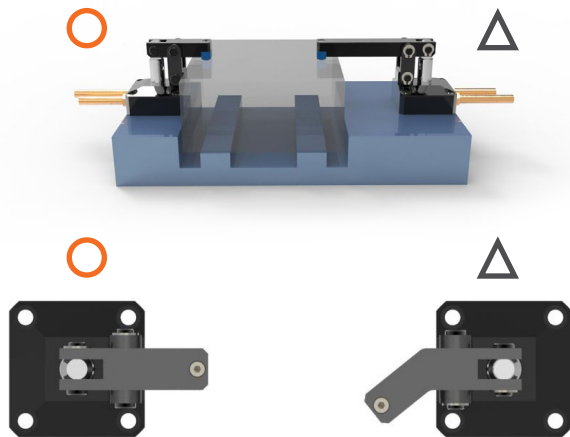

작동 영상

Hinge(Link) Clamp Applications

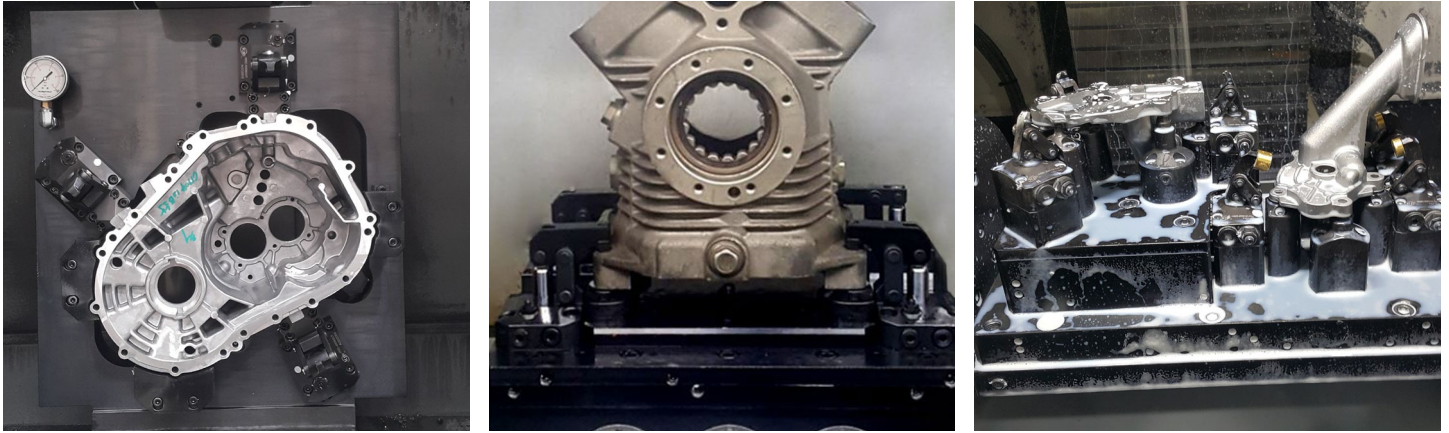

Hinge(Link) Clamp Line-up

	<p>Advanced Compact Type Model No. QHGC-□G</p>	<p>저압용/더욱 컴팩트한 사이즈 Low Pressure More Compact Size</p>	
	<p>Compact type Model No. CHGC-□G</p>	<p>저압용/포트대칭방향 가능 Low Pressure Port Symmetry Direction</p>	 <p>CHGC-xxxxGZ</p>
	<p>Gasket Type Model No. HGC-□G</p>	<p>고압용/매니폴더 배관방식 High pressure Manifold Method</p>	
	<p>Nipple Type Model No. HGC-□</p>	<p>고압용/니플 배관방식 High pressure Nipple Piping Method</p>	
	<p>Double Rod Type Model No. HGC-□D</p>	<p>고압용/더블로드 센싱 타입 High pressure Double rod Sensing Type</p>	
	<p>Tube Type Model No. HGC-□T</p>	<p>고압용/하부 배관 타입 High pressure Bottom Piping Type</p>	

Model No. Explanation

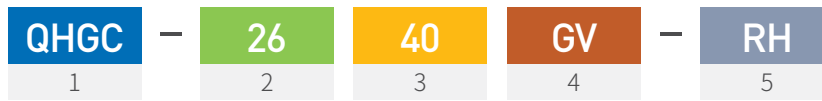

1 Clamp Type

- QHGC:** Compact Hing Clamp(Advanced Type/Low Pressure)
- CHGC:** Compact Hing Clamp(Standard Type/Low Pressure)
- HGC:** Hinge Clamp(High Pressure)

2 Cylinder Inner Diameter(ø)

QHGC	CHGC	HGC
24 = 24mm	20 = 20mm	25 = 25mm
26 = 26mm	25 = 25mm	32 = 32mm
30 = 30mm	30 = 30mm	40 = 40mm
35 = 35mm	35 = 35mm	50 = 50mm
45 = 45mm	44 = 44mm	63 = 63mm
55 = 55mm	56 = 56mm	80 = 80mm
	70 = 70mm	

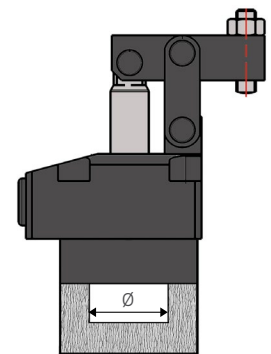

3 Cylinder Outer Diameter(ø) or Aprox. Clamping Force at 70kgf/cm²

QHGC	CHGC	HGC
36 = 36mm	36 = 36mm	02 = 200kgf
40 = 40mm	39 = 39mm	03 = 300kgf
48 = 48mm	47 = 47mm	05 = 500kgf
55 = 55mm	53 = 53mm	09 = 900kgf
65 = 65mm	63 = 63mm	15 = 1,500kgf
75 = 75mm	78 = 78mm	23 = 2,300kgf
	100 = 100mm	

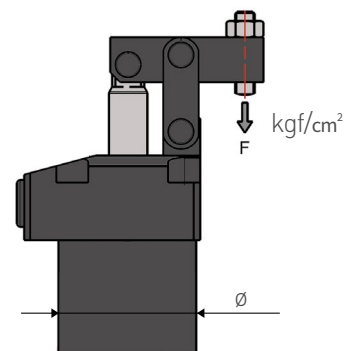

4 Piping Method & Function Type

No sign: Nipple Piping

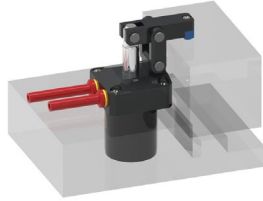

D : Double Rod Piston

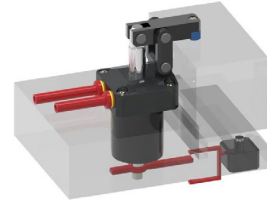

G : Manifold Piping

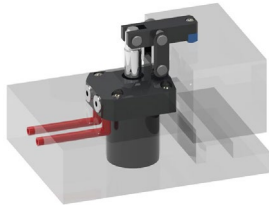

GV : Manifold Piping + Flow Control Valve

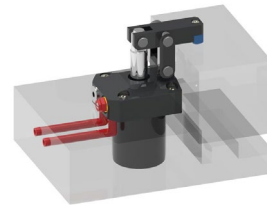

T : Bottom Piping Type 1

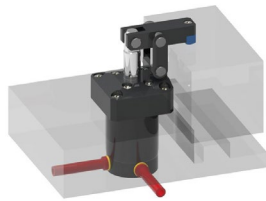

TS : Bottom Piping Type 2

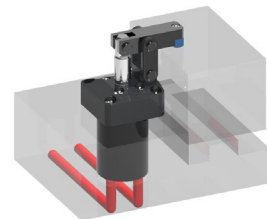

TV : Bottom Piping Type 2 + Flow Control Valve

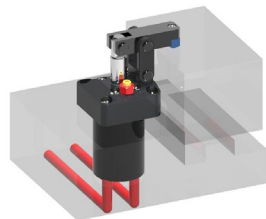

5 Hinge Position

No sign: Center

LH: Left

RH: Right



LH



No sign



RH

Compact Hinge(Link) Clamp Advanced Type(Low Pressure)

Advanced vs Standard
[Equal Piston Diameter]

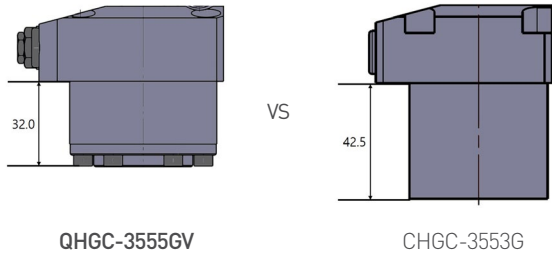

Manifold Method

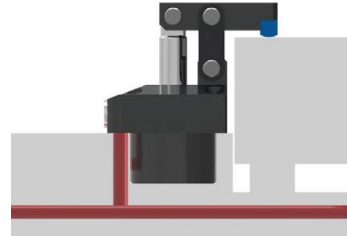

Model No.

QHGC-2640GV-RH



- 1** Clamp Type
QHGC = Advanced Type
- 2** Piston Diameter
ex) 26 = $\varnothing 26$
- 3** Housing Diameter
ex) 40 = $\varnothing 40$
- 4** Type
> G = Gasket
> GV = Gasket + Flow control valve meter-out
- 5** Lever Direction
> RH = Right Side
> LH = Left Side
> No sign = Front

Lever Direction

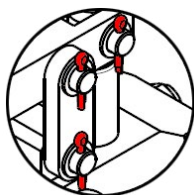
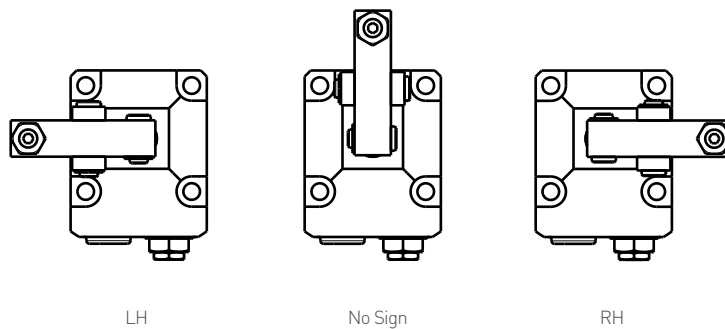

분할핀 사양은 주문제작으로 가능합니다.
The specifications of the split pin can be custom-made.

* 분할 핀 사양
Split pin

Compact Hinge(Link) Clamp **Advanced Type**

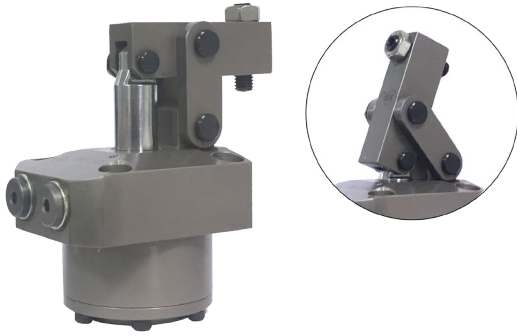

Features

1. 더욱 컴팩트한 사이즈
 2. 설치와 배관 용이
 3. 가스연질화 표면처리
 4. 내경범위 : $\varnothing 24 \sim 55$
 5. 작동압력 : $15 \sim 70 \text{ kgf/cm}^2$
 6. 사용온도 : $0 \sim 70^\circ\text{C}$
 7. 레버는 옵션
1. Advanced Compact size
 2. Easy installation and manifold piping
 3. Gas Nitriding Surface
 4. Piston Diameter : $\varnothing 24 \sim 55$
 5. Operating Pressure : $15 \sim 70 \text{ kgf/cm}^2$
 6. Operating Temperature : $0 \sim 70^\circ\text{C}$
 7. Lever is option item

> QHGC - 26 40 G

① ② ③

QHGC - 26 40 GV

① ② ③

- ① Piston Diameter(mm) ② Housing Diameter(mm)
③ Gasket Type, Gasket Side Valve Type

Specification

MODEL NO.		QHGC-2436G		QHGC-2640G		QHGC-3048G		QHGC-3555G		QHGC-4565G		QHGC-5575G	
Type	Gasket	G	GV	G	GV	G	GV	G	GV	G	GV	G	GV
Clamping force(kgf)	$\varnothing 70 \text{ kgf/cm}^2$	240		297		391		487		852		1,037	
Piston Diameter (mm)		$\varnothing 24$		$\varnothing 26$		$\varnothing 30$		$\varnothing 35$		$\varnothing 45$		$\varnothing 55$	
Effective Area (cm ²)		4.5		5.3		7.1		9.6		15.9		23.8	
Stroke (mm)	Total	18.5		20.5		23.5		26.0		29.5		35.0	
	Clamp	16		17.5		20.5		23.0		26.5		32.0	
	Extra	2.5		3		3		3		3		3	
Oil Capacity (cm ³)	Clamp(PUSH)	7.2		10.9		16.6		25.0		46.9		83.2	
	Undamp(PULL)	5.9		8.6		13.0		19.8		37.7		69.9	
Operating Pressure Range		15 ~ 70 kgf/cm ²											
Operating Temperature Range		0 ~ 70°C											
Weight (kg)		0.5	0.51	0.6	0.61	0.9	0.91	1.2	1.21	2.0	2.01	3.0	3.01

Clamping Force Calculation Formula

Hydraulic Clamp

클램핑력은 치수 K와 사용압력에 따라 변합니다. 아래의 계산식을 통해 클램핑력을 구해 주십시오.

Clamping force varies depending on dimension K and operating pressure.

Use below formula to calculate clamping force.

- > F = Clamping Force(kgf)
- > P = Hydraulic Pressure(kgf/cm²)
- > K = 옆의 도면 참조 Refer to Drawing (mm)

Note.

치수 K가 과도하게 짧을 경우, 최대 압력을 사용하면 클램프에 손상이 가거나 작동유가 새어 나올 수 있습니다.

Using excessively short dimension of K at maximum operating pressure may cause oil leakage and damage.

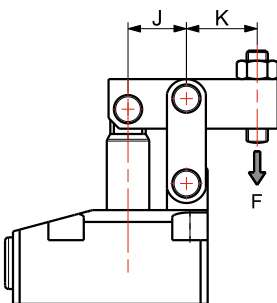

ADVANCED COMPACT

QHGC-2436G : $F = 65.3 \times P / K$

QHGC-2640G : $F = 84.8 \times P / K$

QHGC-3048G : $F = 131.4 \times P / K$

QHGC-3555G : $F = 201.6 \times P / K$

QHGC-4565G : $F = 389.6 \times P / K$

QHGC-5575G : $F = 741.0 \times P / K$

* K 치수: 카탈로그 치수의 30% 이상 커지는 것은 권장 안함.

K Dimension: It is not recommended to exceed 30% of the catalog dimension.

Drawing

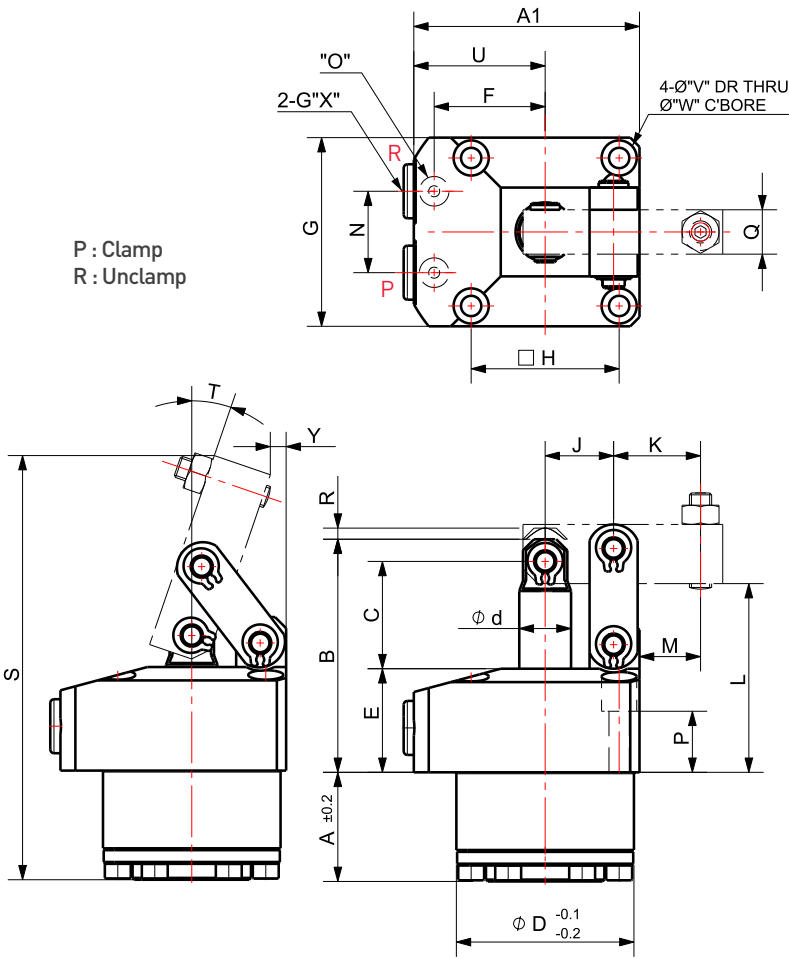

Dimensions

MODEL NO.	QHGC-2436G	QHGC-2640G	QHGC-3048G	QHGC-3555G	QHGC-4565G	QHGC-5575G
A	23	27.5	29.5	32.0	38.5	40.5
A1	49	54.0	61.0	69.0	81.0	94.5
B	52.5	55.5	63.0	65.5	75.0	92.0
C	22.5	25.0	29.0	31.5	37.0	45.0
D	ø36.0	ø40.0	ø48.0	ø55.0	ø65.0	ø75.0
d	ø10.0	ø12.0	ø14.0	ø16.0	ø20.0	ø22.0
E	25	25.0	28.0	28.0	30.0	37.0
F	23.5	26.0	30.0	33.5	39.5	45.0
G	40	45.0	51.0	60.0	70.0	85.0
H	31.5	34.0	40.0	47.0	55.0	63.0
J	14.5	16.0	18.5	21.0	24.5	30.0
K	19	20.0	23.5	29.0	32.0	50.0
L	43	44.5	51.0	53.5	59.0	73.0
M	13.5	13.5	16.5	20.0	21.5	37.5
N	16	18.0	22.0	24.0	30.0	32.0
O	P5	P5	P5	P5	P7	P7
P	16	15.5	16.5	13.5	15.5	17.5
Q	10	12.0	12.0	16.0	19.0	22.0
R	2.5	3.0	3.0	3.0	3.0	3.0
S	91.6	102.8	114.7	127.8	146.3	185.1
T	19.6°	20.2°	18.9°	19.9°	20.5°	21.4°
U	29	31.5	35.5	39.0	46.0	52.0
V	4.5	ø5.5	ø5.5	ø6.8	ø6.8	ø9.0
W	7.5	ø9.5	ø9.5	ø11.0	ø11.0	ø14.0
X	G1/8	G1/8	G1/8	G1/8	G1/8	G1/4
Y	2.9	2.7	4.3	4.7	4.6	0.8

GV Type

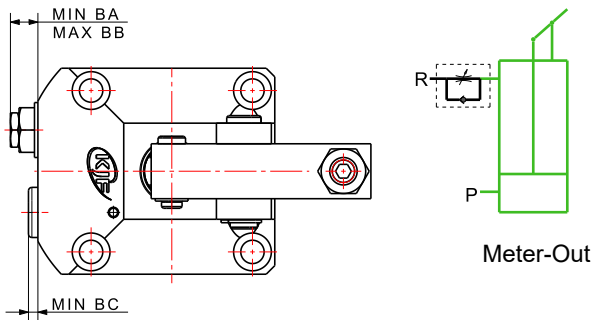

Dimensions

MODEL NO.	QHGC-2436G	QHGC-2640G	QHGC-3048G	QHGC-3555G	QHGC-4565G	QHGC-5575G
BA	7.5	8	8	8	8	11.5
BB	11.5	12	12	12	12	15.5
BC	2.3	2.8	2.8	2.7	2.75	4.5

LEVER (OPTION)

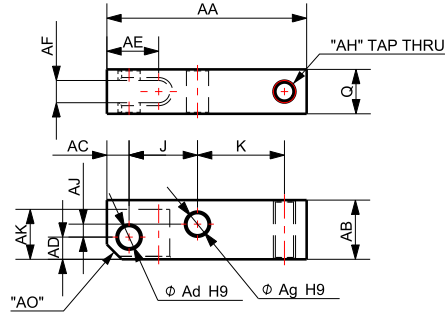

Dimensions

MODEL NO.	QHGC-2436G	QHGC-2640G	QHGC-3048G	QHGC-3555G	QHGC-4565G	QHGC-5575G
AA	43	48.0	54.0	64.0	73.5	90.5
AB	12.5	14.0	16.0	20.0	25.0	31.0
AC	4.5	5.5	6.0	6.0	8.0	10.0
AD	4.5	5.5	6.0	6.0	8.0	9.0
Ad	∅5.0	∅6.0	∅6.0	∅6.0	∅8.0	∅10.0
AE	10	11.0	14.0	13.0	16.0	21.0
AF	5	6.0	6.0	8.0	10.0	11.0
Ag	∅5.0	∅6.0	∅6.0	∅8.0	∅10.0	∅12.0
AH	M5	M6	M6	M8	M10	M12
AJ	2.5	2.5	3.5	6.0	7.5	9.5
AK	10.5	12.0	13.5	13.5	17.5	23.0
A0	C3.5	C3.0	C4.0	C4.0	R8.0	C7.0

Mounting Detail

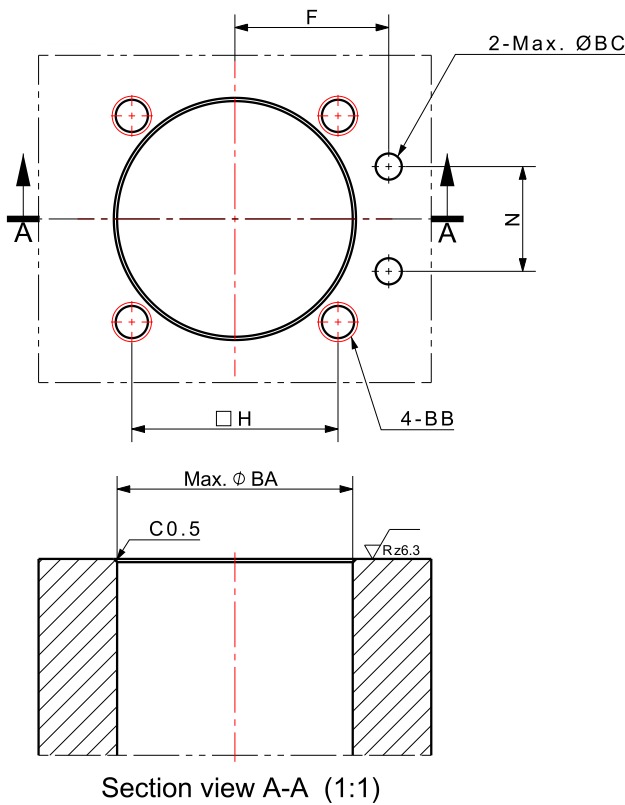

Dimensions

MODEL NO.	F	H	N	ØBA	BB	ØBC
QHGC-2436G	23.5	31.5	16.0	37.0	M4	4.0
QHGC-2640G	26.0	34.0	18.0	41.0	M5	4.0
QHGC-3048G	30.0	40.0	22.0	49.0	M5	4.0
QHGC-3555G	33.5	47.0	24.0	56.0	M6	4.0
QHGC-4565G	39.5	55.0	30.0	66.0	M6	6.0
QHGC-5575G	45.0	63.0	32.0	76.0	M8	6.0

Compact Hinge(Link) Clamp Standard Type(Low Pressure)

Compact type vs Gasket type

Equal Piston Diameter

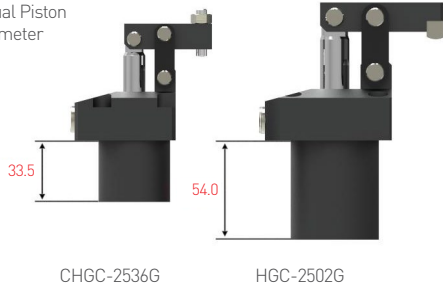

Manifold Method

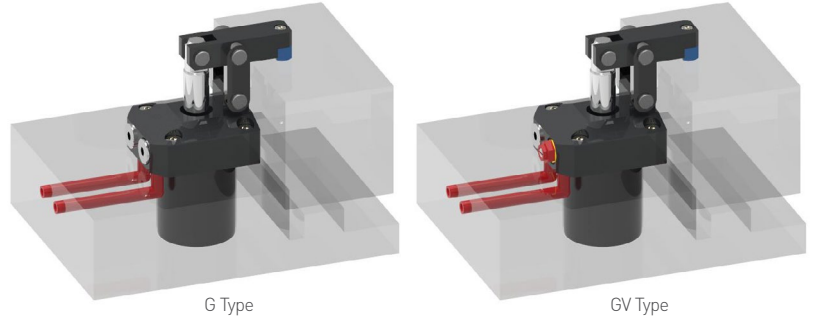

포트반대구조 Port Opposite Direction(Option)

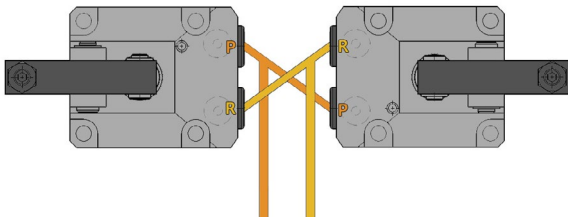

일반포트방향 Normal Port Direction

VS

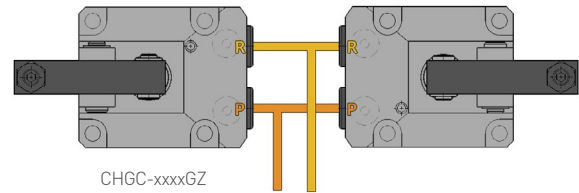

포트대칭방향 Port SymmetryDirection

- * 위의 구성으로 설치 시 유로구성의 편의성 제공
- * Providing convenience of making oil path

Model No.

CHGC-2036GV-RH

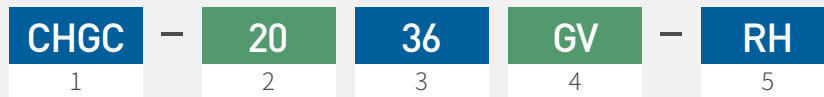

1 Clamp Type
CHGC = COMPACT HINGE CLAMP

2 Piston Diameter
ex) 20 = $\varnothing 20$

3 Housing Diameter
ex) 36 = $\varnothing 36$

4 Type

- > G = Gasket
- > GV = Gasket + Flow control valve, * V: meter-in valve W: meter-out valve
- > GVT = Gasket + Flow control valve, Meter-out method
- > Z = port opposite structure (포트반대구조)

5 Lever Direction

- > RH = Right Side
- > LH = Left Side
- > No sign = Front

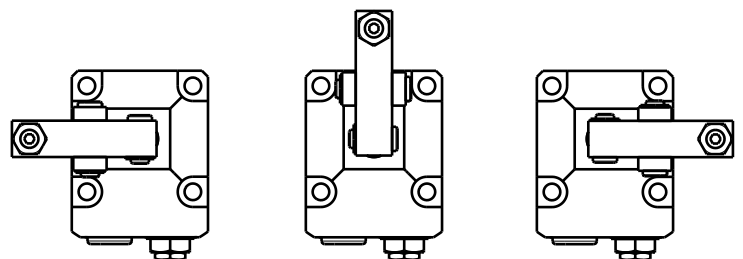

CHGC-xxxxGV-LH

CHGC-xxxxGV

CHGC-xxxxGV-RH

Specification

Gasket Type

* 클램핑력은 표준치수 레버 적용 기준임.
* The clamping force in the table below relates to the standard dimension lever.

MODEL NO.		CHGC-2036 □		CHGC-2539 □		CHGC-3047 □		CHGC-3553 □		CHGC-4463 □		CHGC-5678 □		CHGC-70100 □	
Type	Gasket	G	GV	G	GV	G	GV	G	GV	G	GV	G	GV	G	GV
Clamping force(kgf)	∅ 70 kgf/cm ²	167		280		390		490		810		1,350		2,020	
Piston Diameter (mm)		∅20		∅25		∅30		∅35		∅44		∅56		∅70	
Effective Area (cm ²)		3.14		4.91		7.07		9.62		15.2		24.62		38.47	
Stroke (mm)	Total	18.5		20.5		23.5		26		29.5		36		45	
	Clamp	16		17.5		20.5		23		26.5		33		42	
	Extra	2.5		3		3		3		3		3		3	
Oil Capacity (cm ³)	Clamp(PUSH)	5.8		10.1		16.6		25.0		44.8		88.6		173.1	
	Unclamp(PULL)	4.3		7.7		13.0		21.0		38.9		74.4		145.4	
Operating Pressure Range		15 ~ 70 kgf/cm ²													
Operating Temperature Range		0 ~ 60°C													
Weight (kg)		0.66	0.67	0.78	0.79	1.08	1.09	1.51	1.52	2.64	2.65	4.46	4.47	8.63	8.64

Clamping Force Calculation Formula

Hydraulic Clamp

클램핑력은 치수 K와 사용압력에 따라 변합니다. 아래의 계산식을 통해 클램핑력을 구해 주십시오.

Clamping force varies depending on dimension K and operating pressure.
Use below formula to calculate clamping force.

- > F = Clamping Force(kgf)
- > P = Hydraulic Pressure(kgf/cm²)
- > K = 옆의 도면 참조 Refer to Drawing (mm)

Note.

치수 K가 과도하게 짧을 경우, 최대 압력을 사용하면 클램프에 손상이 가거나 작동유가 새어 나올 수 있습니다. Using excessively short dimension of K at maximum operating pressure may cause oil leakage and damage.

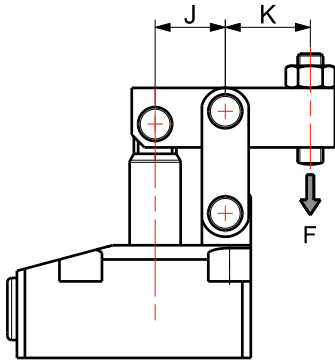

COMPACT

CHGC-2036G : F = 45.5 x P/K

CHGC-2539G : F = 80.9 x P/K

CHGC-3047G : F = 130.7 x P/K

CHGC-3553G : F = 201.9 x P/K

CHGC-4463G : F = 372.3 x P/K

CHGC-5678G : F = 750.8 x P/K

CHGC-70100G : F = 1,442.4 x P/K

* K 치수: 카탈로그 치수의 30% 이상 커지는 것은 권장 안함.
K Dimension: It is not recommended to exceed 30% of the catalog dimension.

Air Sensor Type

클램프와 언클램프 감지용 에어센서 타입은 주문제작으로 공급해 드립니다. 문의 바랍니다.

Air Sensor type for detecting clamp and unclamp is able to be provided as customized design. Please contact us.

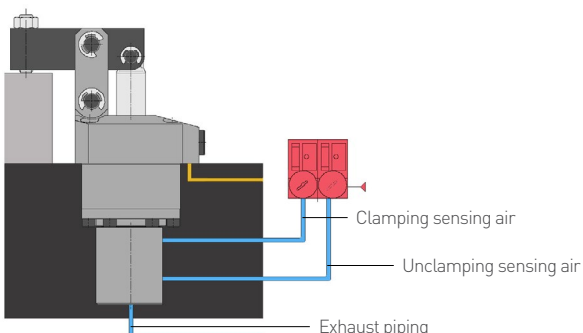

Compact Hinge(Link) Clamp Standard Type



Features

- | | |
|--------------------------------------|---|
| 1. 컴팩트한 사이즈 | 1. Compact size |
| 2. 설치와 배관 용이 | 2. Easy installation and manifold piping |
| 3. 가스연질화 표면처리 | 3. Gas Nitriding Surface |
| 4. 내경범위 : $\phi 20\sim 70$ | 4. Piston Diameter : $\phi 20\sim 70$ |
| 5. 작동압력 : $15\sim 70\text{kgf/cm}^2$ | 5. Operating Pressure : $15\sim 70\text{kgf/cm}^2$ |
| 6. 사용온도 : $0\sim 60^\circ\text{C}$ | 6. Operating Temperature : $0\sim 60^\circ\text{C}$ |
| 7. 레버는 옵션 | 7. Lever is option item |

> CHGC - 20 36 G

① ② ③

① Piston Diameter(mm) ② Housing Diameter(mm) ③ Gasket Type

Manifold Method

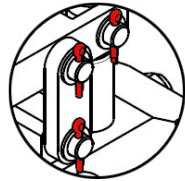
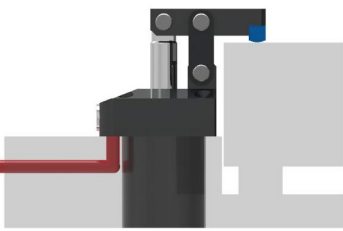

* 분할 핀 사양
주문제작
Split pin
custom-made.

P : Clamp
R : Unclamp

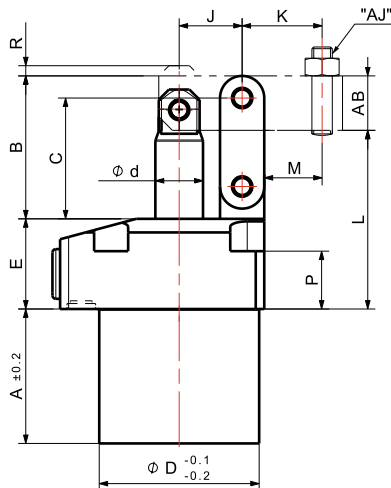
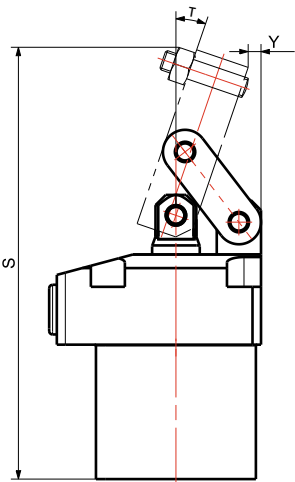
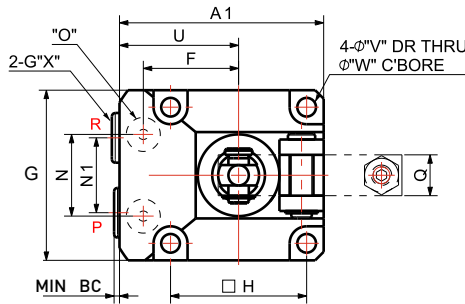

LEVER (OPTION)

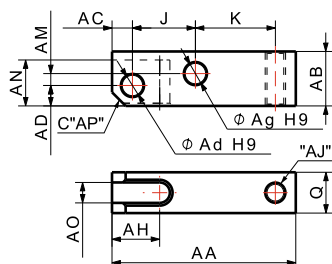

Dimensions

MODEL NO.	CHGC-2036G	CHGC-2539G	CHGC-3047G	CHGC-3553G	CHGC-4463G	CHGC-5678G	CHGC-70100G
A	38.5	33.5	39.5	42.5	47	55	65
A1	49	55.0	60	66	82	96	120
B	30.5	37	42	48.5	57	71	87
C	25	31.5	35.5	40.5	47.5	58.5	71
φD	36	39	47	53	63	78	100
φd	10	12	14	14	16	22.4	28
E	25	26.5	26.5	28.5	36	40	47
F	23.5	25	28	30.5	36	42	57
G	40	45	50	57	70	86	108
H	31.5	35	40	46	56	68	88
J	14.5	16.5	18.5	21	24.5	30.5	37.5
K	19	20	23.5	29	32	39	50
L	43	49.5	52.5	57	68	80	96
M	13.5	14	17	21.5	21.5	26.5	33.5
N	16	22	24	28	36	45	50
N1	16	20	22	26	30	38	50
O	P5	P7	P7	P7	P8	P9	P10
P	16	18	17	17	20	20	20
Q	10	12	12	16	19	22	32
R	2.5	3	3	3	3	3	3
S	108.5	108.6	126.2	141.8	164.7	194.1	236.8
T	19.6°	21.2°	18.9°	19.9°	20.5°	20.6°	18.4°
U	29	32.5	35	37.5	47	53	66
V	4.5	5.5	5.5	6.8	9	11	14
W	8	10	10	12	15	18.5	20
X	G1/8	G1/8	G1/8	G1/8	G1/4	G3/8	G3/8
Y	2.9	2	3.8	3.2	4.3	6.2	9.8
AA	43	48	54	64	73.5	90.5	115.5
AB	12.5	14	16	20	25	31	38
AC	4.5	5.5	6	6	7	10	13
AD	4.5	5.5	6	6	8	9	12.5
Ad	5	6	6	6	8	12	14
Ag	5	6	6	8	10	14	16
AH	10	11	14	13	17	21	28
AJ	M5	M6	M6	M8	M10	M12	M16
AM	2.5	3	3.5	6	7.5	9.5	9.5
AN	10.5	12	13.5	13.5	18	23	29
AO	5	6	6	8	10	11	16
AP	C3.5	C3.0	C4.0	C4.0	C5.0	C7.0	C8.0
BC	3.4	2.4	2.4	2.4	2.4	5.1	5.1



Compact Hinge(Link) Clamp Standard Valve Type

Features

1. 유량조절밸브 장착
 2. 설치와 배관 용이
 3. 가스연질화 표면처리
 4. 내경범위 : $\phi 20\sim 70$
 5. 작동압력 : $15\sim 70\text{kgf/cm}^2$
 6. 사용온도 : $0\sim 60^\circ\text{C}$
 7. 레버는 옵션
1. Flow control valve mounted
 2. Easy installation and manifold piping
 3. Gas Nitriding Surface
 4. Piston Diameter : $\phi 20\sim 70$
 5. Operating Pressure : $15\sim 70\text{kgf/cm}^2$
 6. Operating Temperature : $0\sim 60^\circ\text{C}$
 7. Lever is option item

> CHGC - 20 36 GV(GVT)

① ② ③

- ① Piston Diameter(mm) ② Housing Diameter(mm)
③ Gasket Side Valve Type(Gasket Valve Top Type)

GV Type

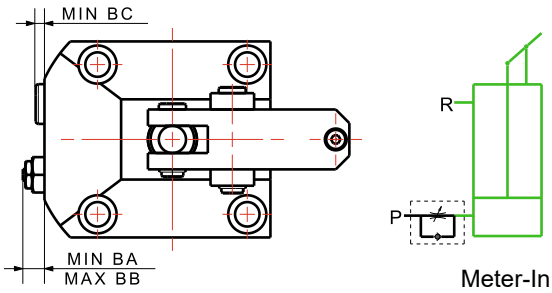

Dimensions

MODEL NO.	CHGC-2036GV	CHGC-2539GV	CHGC-3047GV	CHGC-3553GV	CHGC-4463GV	CHGC-5678GV	CHGC-70100GV
BA	7.5	6.6	6.6	6.6	7.15	7.1	7.1
BB	11.5	13.2	13.2	13.2	16.75	17.1	17.1
BC	3.4	2.4	2.4	2.4	2.4	5.1	5.1

GVT Type

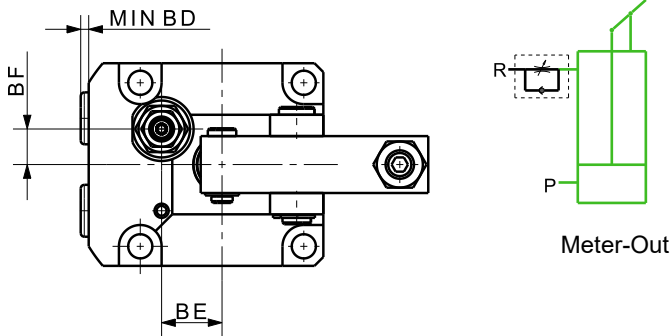

Gasket + Valve Top(GVT) Type

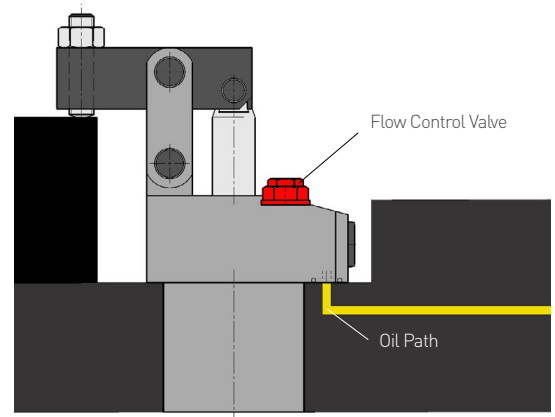

Dimensions

MODEL NO.	CHGC-2036GVT	CHGC-2539GVT	CHGC-3047GVT	CHGC-3553GVT	CHGC-4463GVT	CHGC-5678GVT	CHGC-70100GVT
BD	0.0	0.0	0.0	2.3	3.5	3.5	5.0
BE	21.0	18.0	20.0	17.0	23.0	31.0	35.0
BF	5.0	5.0	7.5	10.0	12.0	15.0	24.0
BG	3.5	4.0	4.0	5.5	7.0	6.0	6.0
BH	7.5	8.0	8.0	9.5	11.0	10.0	10.0

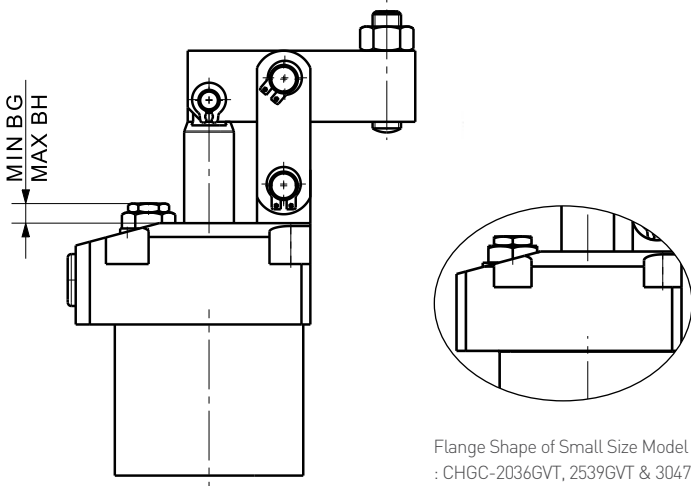

Flange Shape of Small Size Model
: CHGC-2036GVT, 2539GVT & 3047GVT

Mounting Detail

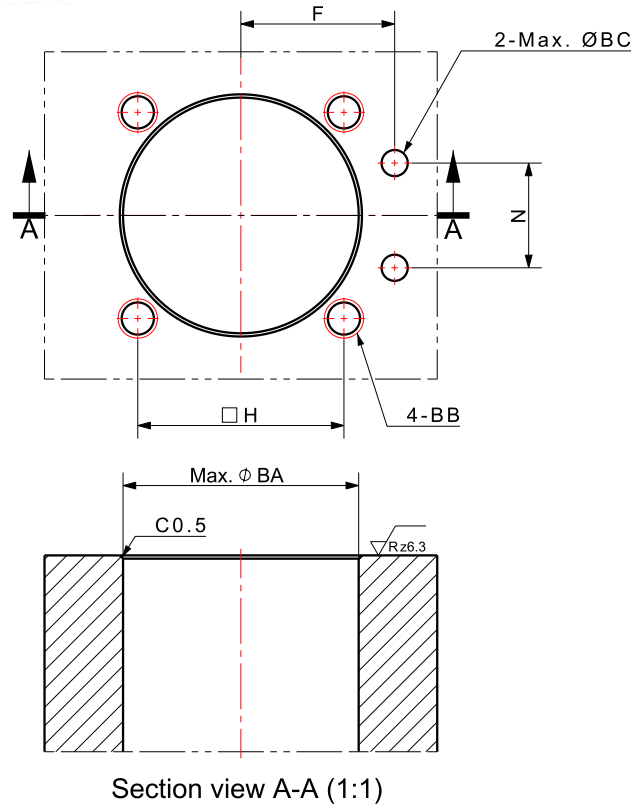

Dimensions

	MODEL NO.	F	H	N	ØBA	BB	ØBC
DIMENSIONS (mm)	CHGC-2036G	23.5	31.5	16.0	37.0	M4	4.0
	CHGC-2539G	25.0	35.0	22.0	40.0	M5	6.0
	CHGC-3047G	28.0	40.0	24.0	48.0	M5	6.0
	CHGC-3553G	30.5	46.0	28.0	54.0	M6	6.0
	CHGC-4463G	36.0	56.0	36.0	64.0	M8	7.0
	CHGC-5678G	42.0	68.0	45.0	79.0	M10	8.0
	CHGC-70100G	57.0	88.0	50.0	101.0	M12	9.0

Memo



Hinge(Link) Clamp Gasket Type

Manifold Method

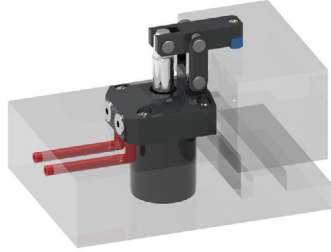

G Type

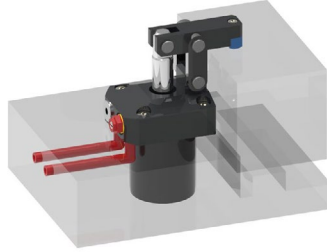

GV Type

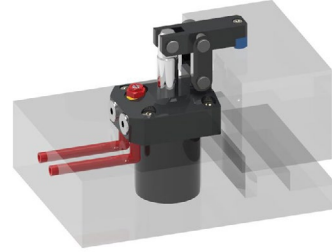

GVT Type

Model No.

HGC-2502GV-RH



1 Clamp Type
HGC = HINGE CLAMP

2 Piston Diameter
ex) 25 = $\varnothing 25$

3 Clamping Force
ex) 02 = 200kgf at 70kgf/cm²

4 Type
 > G = Gasket
 > GV = Gasket + Flow control valve, * V: meter-in valve W: meter-out valve
 > GVT = Gasket + Flow control valve Top, Meter-out method

5 Lever Direction
 > RH = Right Side
 > LH = Left Side
 > No sign = Front

Lever Direction

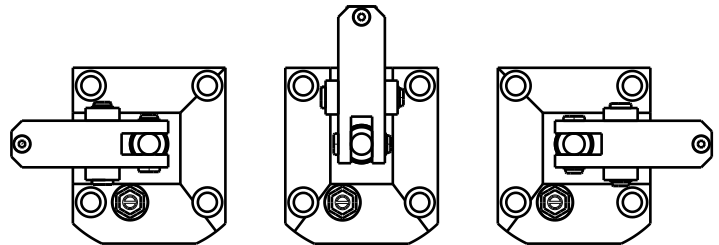

HGC-xxxxGVT-LH

HGC-xxxxGVT

HGC-xxxxGVT-RH

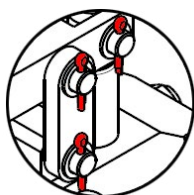

* 분할 핀 사양
Split pin

분할핀 사양은 주문제작으로 가능합니다.
The specifications of the split pin can be custom-made.

Specification

Gasket Type

* 클램핑력은 표준치수 레버적용 기준임.
 * The Clamping force in the table below relates to the standard dimension lever.

MODEL NO.		HGC-2502 □			HGC-3203 □			HGC-4005 □			HGC-5009 □			HGC-6315 □			HGC-8023 □		
Type	Gasket	G	GV	GVT	G	GV	GVT	G	GV	GVT	G	GV	GVT	G	GV	GVT	G	GV	GVT
Clamping force (kgf)	∅ 70 kgf/cm ²	228			325			544			935			1,563			2,344		
	∅ 150 kgf/cm ²	490			698			1,166			2,004			3,351			5,023		
Piston Diameter (mm)		∅25			∅32			∅40			∅50			∅63			∅80		
Effective Area (cm ²)		4.9			8.04			12.56			19.63			31.16			50.24		
Stroke (mm)	Total	28			28			33			42			50			60		
	Clamp	26			26			31			38			46			56		
	Extra	2			2			2			4			4			4		
Oil Capacity (cm ³)	Clamp(PUSH)	13.7			22.5			41.4			82.5			155.8			301.4		
	Undclamp(PULL)	8.1			15.4			25.2			52.8			106.3			206		
Operating Pressure Range		15-150kgf/cm ²																	
Operating Temperature Range		0-60°C																	
Weight(kg)		1.73	1.73	1.72	2.26	2.27	2.27	3.37	3.38	3.39	5.67	5.68	5.68	9.06	9.07	9.07	15.28	15.29	15.28

Clamping Force Calculation Formula

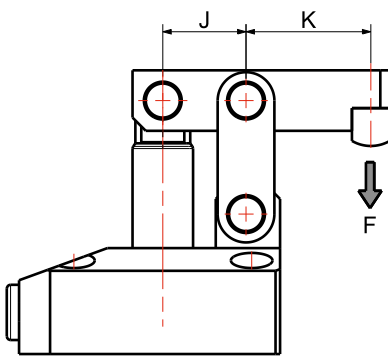

Hydraulic Clamp

클램핑력은 치수 K와 사용압력에 따라 변합니다.
 아래의 계산식을 통해 클램핑력을 구해 주십시오.

Clamping force varies depending on dimension K and operating pressure.
 Use below formula to calculate clamping force.

- > F = Clamping Force(kgf)
- > P = Hydraulic Pressure(kgf/cm²)
- > K = 옆의 도면 참조 Refer to Drawing (mm)

Note.

치수 K가 과도하게 짧을 경우, 최대 압력을 사용하면 클램프에 손상이 가거나 작동유가 새어 나올 수 있습니다.
 Using excessively short dimension of K at maximum operating pressure may cause oil leakage and damage.

STANDARD / GASKET / TUBE

- HGC-2502 □ : F = 107.8 x P / K
- HGC-3203 □ : F = 176.9 x P / K
- HGC-4005 □ : F = 326.6 x P / K
- HGC-5009 □ : F = 628.2 x P / K
- HGC-6315 □ : F = 1,184.1 x P / K
- HGC-8023 □ : F = 2,311.0 x P / K

* K 치수: 카달로그 치수의 30% 이상 커지는 것은 권장 안함.
 K Dimension: It is not recommended to exceed 30% of the catalog dimension.



Hinge(Link) Clamp Gasket Type

Features

1. 매니폴더 배관이 용이
 2. 빠른 클램핑 / 언클램핑 속도
 3. 칩 배출 용이
 4. 내경범위 : $\phi 25\sim 80$
 5. 작동압력 : $15\sim 150\text{kgf/cm}^2$
 6. 사용온도 : $0\sim 60^\circ\text{C}$
 7. 레버는 옵션
1. Easy manifold piping
 2. Rapid clamping and unclamping
 3. Easy removal of chips
 4. Piston Diameter : $\phi 25\sim 80$
 5. Operating Pressure : $15\sim 150\text{kgf/cm}^2$
 6. Operating Temperature : $0\sim 60^\circ\text{C}$
 7. Lever is option item

> HGC - 25 02 G

① ② ③

① Piston Diameter(mm) ② Clamping Force at 70kgf/cm^2 ③ Gasket Type

Manifold Method

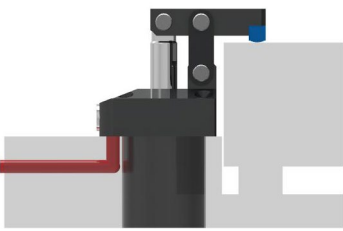

P : Clamp
R : Unclamp

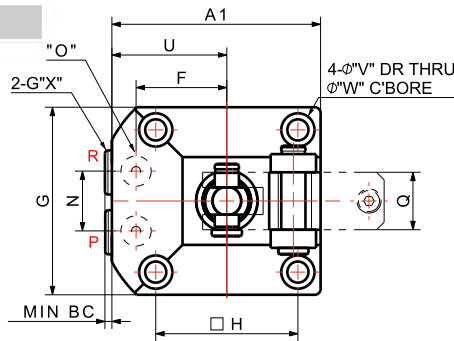

Dimensions

MODEL NO.	HGC-2502G	HGC-3203G	HGC-4005G	HGC-5009G	HGC-6315G	HGC-8023G
A	54	54	60	78	89	100
A1	69	83	92	104	121	148.5
B	75	80	90	108	127	158
C	39	42.5	47.5	57.5	71	86
ϕD	48	55	65	80	95	115
ϕd	16	18	25	30	35.5	45
E	28	27.5	29.0	34.5	36	48
F	30	35	40	48	55	70
G	62	72	80	88	108	125
H	47	55	63	70	85	100
J	22	22	26	32	38	46
K	33	38	42	47	53	69
L	55	58	63	76	85	108
M	24	24	28	35	37	52.5
N	24	26	31	33	39	46
O	P7	P10	P10	P10	P10	P10
P	14	13.5	15	17.5	16	23
Q	19	22	25	32	40	44
R	2	2	2	4	4	4
S	155	163	180.4	220	252	306
T	15.2°	13.0°	14.3°	14.3°	14.0°	13.7°
U	38	47	52	60	67	86
V	7	9	9	9	11	14
W	11	14	14	14	17.5	20
X	G1/8	G1/8	G1/4	G3/8	G3/8	G3/8
Y	4.6	10.5	9.4	8.5	10	9.1
AA	68	74	85	100	118	147
AB	16	18	22	26	34	40
AC	8	9	11	13	17	20
AD	8	9	11	13	17	20
Ad	8	8	10	12	16	18
AE	10	10	12	16	20	24
AF	6	7	9	10	13	16
AH	20	22	26	32	40	46
AJ	4.5	4.5	6	6.6	9	11
AK	8	8	9.5	11	14	17.5
AL	4.4	4.4	6	7	8.6	11
AO	9	10	12	16	20	24
BC	3.4	3.4	3.4	3.4	3.4	6
CA	14	14	16	20	25	28
CB	10	10	12	16	20	24
CC	10	10	12	13	18	22
CD	10	10	10	15	20	25
CE	M4	M4	M5	M6	M8	M10
CF	6	6	6	7	9	12

LEVER (OPTION)

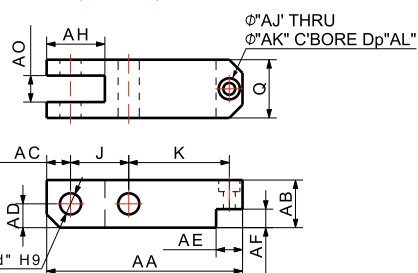

PAD (OPTION)

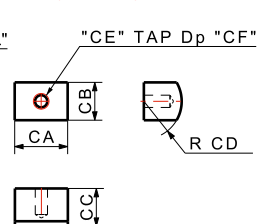



Hinge(Link) Clamp GV / GVT Type

Features

- | | |
|---------------------------------------|---|
| 1. 매니폴더 배관 용이 | 1. Easy manifold piping |
| 2. 유량조절밸브 장착형 | 2. Flow control valve mounted |
| 3. 유량조절밸브 위치 선택가능 | 3. 2-position flow control valve |
| 4. 내경범위 : $\phi 25\sim 80$ | 4. Piston Diameter : $\phi 25\sim 80$ |
| 5. 작동압력 : $15\sim 150\text{kgf/cm}^2$ | 5. Operating Pressure : $15\sim 150\text{kgf/cm}^2$ |
| 6. 사용온도 : $0\sim 60^\circ\text{C}$ | 6. Operating Temperature : $0\sim 60^\circ\text{C}$ |
| 7. 레버는 옵션 | 7. Lever is option item |

> HGC - 25 02 GV

- ① Piston Diameter
- ② Clamping Force at 70kgf/cm^2
- ③ Gasket Side Valve Type

HGC - 25 02 GVT

- ① Piston Diameter
- ② Clamping Force at 70kgf/cm^2
- ③ Gasket Top Valve Type

GV Type

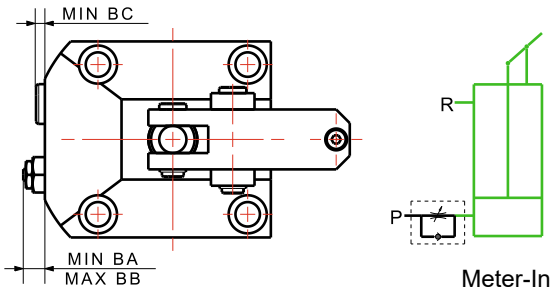

Dimensions

MODEL NO.	HGC-2502GV	HGC-3203GV	HGC-4005GV	HGC-5009GV	HGC-6315GV	HGC-8023GV
DIMENSIONS (mm)						
BA	7	7	10.5	10.5	10.5	10.5
BB	11	11	14.5	14.5	14.5	14.5
BC	3.4	3.4	3.4	3.4	3.4	6

GVT Type

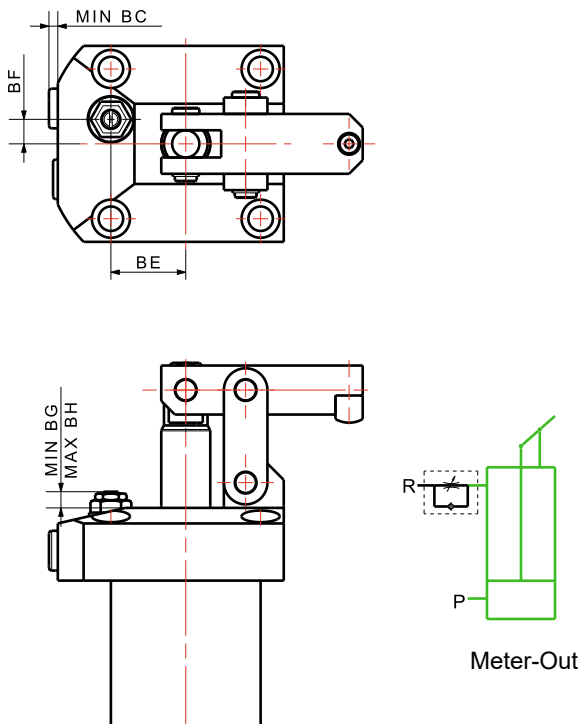

Dimensions

MODEL NO.	HGC-2502GVT	HGC-3203GVT	HGC-4005GVT	HGC-5009GVT	HGC-6315GVT	HGC-8023GVT
DIMENSIONS (mm)						
BE	22	27.5	31.5	35	42	46
BF	8	9	11	15	19.5	23
BG	2.5	4.5	9	6	6	5
BH	6.5	8.5	13	10	10	9

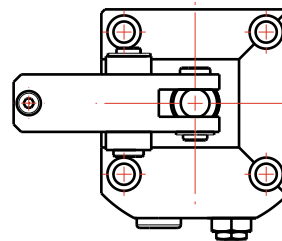

HGC-xxxxGV-LH

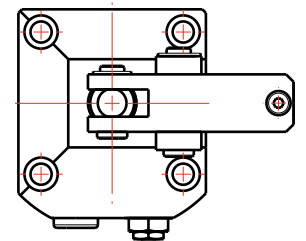

HGC-xxxxGV-RH

* G-RH/LH, GV-RH/LH type 주문가능.

(레버 방향은 위의 그림 참조)

G-RH/LH and GV-RH/LH are available to be ordered.

(Refer to above drawing)

Mounting Detail

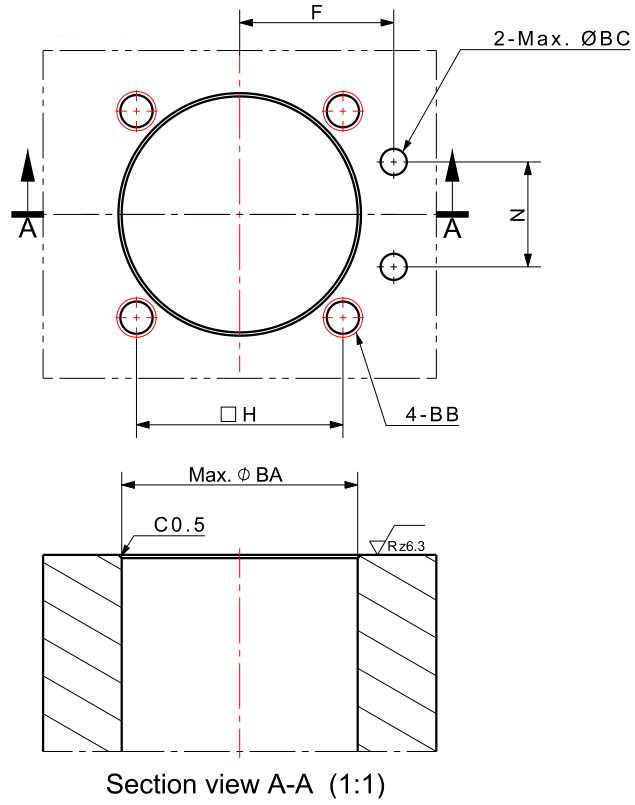

Dimensions

	MODEL NO.	F	H	N	ØBA	BB	ØBC
DIMENSIONS (mm)	HGC-2502G	30.0	47.0	24.0	49.0	M6	6.0
	HGC-3203G	35.0	55.0	26.0	56.0	M8	9.0
	HGC-4005G	40.0	63.0	31.0	66.0	M8	9.0
	HGC-5009G	48.0	70.0	33.0	81.0	M8	9.0
	HGC-6315G	55.0	85.0	39.0	96.0	M10	9.0
	HGC-8023G	70.0	100.0	46.0	116.0	M12	9.0

Hinge(Link) Clamp Nipple Piping Products

Piping Method

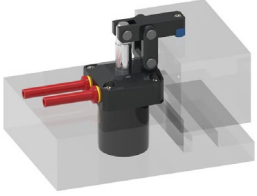

Standard type

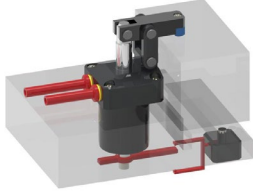

Double Rod type

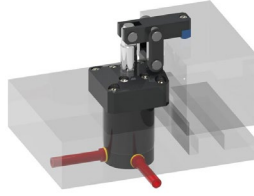

T type

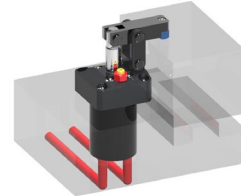

TV type

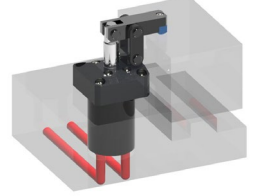

TS type

Model No.

HGC-2502T

HGC	-	25	02	T
1		2	3	4

1 Clamp Type
HGC = HINGE CLAMP

2 Piston Diameter
ex) 25 = ø25

3 Clamping Force
ex) 02 = 200kgf at 70kgf/cm²

4 Type

- > No Sign = Standard
- > T = Tube
- > TV = Tube+Flow control valve
- > TS = Tube under bottom
- > D = Double Rod

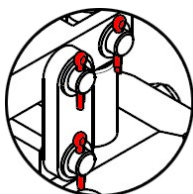

* 분할 핀 사양
Split pin

분할핀 사양은 주문제작으로 가능합니다.
The specifications of the split pin can be custom-made.

Specification

Standard / Tube Type

* 클램핑력은 표준치수 레버적용 기준임.
 * The clamping force in the table below relates to the standard dimension lever.

MODEL NO.		HGC-2502 □			HGC-3203 □			HGC-4005 □			HGC-5009 □			HGC-6315 □			HGC-8023 □		
Type	Standrad	No sign			No sign			No sign			No sign			No sign			No sign		
	Tube	T	TV	TS	T	TV	TS	T	TV	TS	T	TV	TS	T	TV	TS	T	TV	TS
Operating Pressure Range		Standard type: 15~150kgf/cm ² , Tube type: 15~70kgf/cm ²																	
Clamping force (kgf)	∅ 70 kgf/cm ²	228			325			544			935			1,563			2,344		
	∅ 150 kgf/cm ²	490			698			1,166			2,004			3,351			5,023		
Piston Diameter (mm)		∅25			∅32			∅40			∅50			∅63			∅80		
Effective Area (cm ²)		4.9			8.04			12.56			19.63			31.16			50.24		
Stroke (mm)	Total	28			28			33			42			50			60		
	Clamp	26			26			31			38			46			56		
	Extra	2			2			2			4			4			4		
Oil Capacity (cm ³)	Clamp(PUSH)	13.7			22.5			41.4			82.5			155.8			301.4		
	Unclamp(PULL)	8.1			15.4			25.2			52.8			106.3			206		
Operating Temperature Range		0~60°C																	
Weight (kg)	Standard	1.48			1.90			2.80			4.77			7.65			12.73		
	Tube	1.73	1.73	1.72	2.26	2.27	2.27	3.37	3.38	3.39	5.67	5.68	5.68	9.06	9.07	9.07	15.28	15.29	15.28

* 클램핑력은 표준치수 레버적용 기준임.
 * The clamping force in the table below relates to the standard dimension lever.

Double Rod Type

MODEL NO.		HGC-2502 D			HGC-3203 D			HGC-4005 D			HGC-5009 D			HGC-6315 D			HGC-8023 D		
Clamping force (kgf)	∅ 70 kgf/cm ²	157			244			457			785			1,406			2,198		
	∅ 150 kgf/cm ²	336			523			979			1,683			3,013			4,710		
Piston Diameter (mm)		∅25			∅32			∅40			∅50			∅63			∅80		
Effective area (cm ²)		3.37			6.03			10.55			16.49			28.02			47.1		
Stroke (mm)	Total	28			28			33			42			50			60		
	Clamp	26			26			31			38			46			56		
	Extra	2			2			2			4			4			4		
Oil Capacity (cm ³)	Clamp(PUSH)	9.4			16.8			34.8			69.2			140			282.6		
	Unclamp(PULL)	8.1			15.3			25.2			52.7			106.3			206		
Operating Pressure Range		15 ~ 150 kgf/cm ²																	
Operating Temperature Range		0 ~ 60°C																	
Weight (kg)		1.63			2.16			3.1			5.33			8.66			14.35		

Clamping Force Calculation Formula

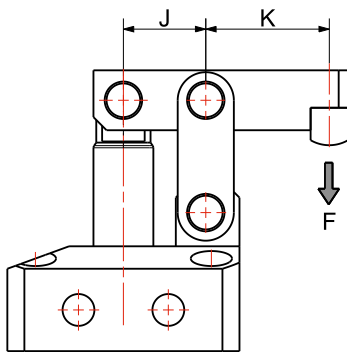

Hydraulic Clamp

클램핑력은 치수 K와 사용압력에 따라 변합니다.
 아래의 계산식을 통해 클램핑력을 구해 주십시오.

Clamping force varies depending on dimension K and operating pressure.
 Use below formula to calculate clamping force.

- > F = Clamping Force(kgf)
- > P = Hydraulic Pressure(kgf/cm²)
- > K = 옆의 도면 참조 Refer to Drawing (mm)

Note.

치수 K가 과도하게 짧을 경우, 최대 압력을 사용하면 클램프에 손상이 가거나 작동유가 새어 나올 수 있습니다.
 Using excessively short dimension of K at maximum operating pressure may cause oil leakage and damage.

STANDARD / GASKET / TUBE

- HGC-2502□ : F = 107.8 x P / K
- HGC-3203□ : F = 176.9 x P / K
- HGC-4005□ : F = 326.6 x P / K
- HGC-5009□ : F = 628.2 x P / K
- HGC-6315□ : F = 1,184.1 x P / K
- HGC-8023□ : F = 2,311.0 x P / K

DOUBLE RODS

- HGC-2502D : F = 73.9 x P / K
- HGC-3203D : F = 132.6 x P / K
- HGC-4005D : F = 274.3 x P / K
- HGC-5009D : F = 527.7 x P / K
- HGC-6315D : F = 1,064.8 x P / K
- HGC-8023D : F = 2,166.6 x P / K

* K 치수: 카탈로그 치수의 30% 이상 커지는 것은 권장 안함.
 K Dimension: It is not recommended to exceed 30% of the catalog dimension.



Hinge(Link) Clamp Standard Type

Features

1. 세방향 배관 포트
2. 쉬운 설치와 배관
3. 편리한 제품 장탈착
4. 내경범위 : $\phi 25 \sim 80$
5. 작동압력 : $15 \sim 150 \text{kgf/cm}^2$
6. 사용온도 : $0 \sim 60^\circ\text{C}$
7. 레버는 옵션
1. 3-direction piping port
2. Easy installation and piping
3. Easy loading and removal of workpiece
4. Piston Diameter : $\phi 25 \sim 80$
5. Operating Pressure : $15 \sim 150 \text{kgf/cm}^2$
6. Operating Temperature : $0 \sim 60^\circ\text{C}$
7. Lever is option item

> HGC - 25 02

- ① Piston Diameter ② Clamping Force at 70kgf/cm^2

Piping Method

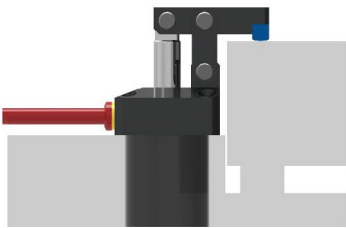

P : Clamp
R : Unclamp

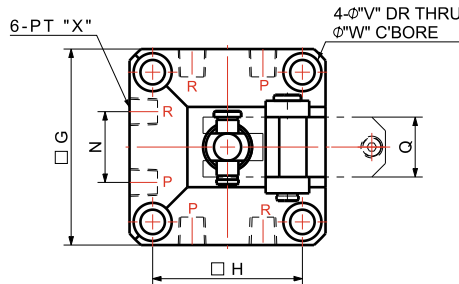

Dimensions

MODEL NO.	HGC-2502	HGC-3203	HGC-4005	HGC-5009	HGC-6315	HGC-8023
A	54	54	60	78	89	100
B	75	80	90	108	127	158
C	39	42.5	47.5	57.5	71	86
ϕD	48	55	65	80	95	115
ϕd	16	18	25	30	35.5	45
E	28	27.5	29.0	34.5	36	48
F	11	11	12	14	14	22.5
G	62	72	80	88	108	125
H	47	55	63	70	85	100
J	22	22	26	32	38	46
K	33	38	42	47	53	69
L	55	58	63	76	85	108
M	24	24	28	35	37	52.5
N	24	26	31	33	39	46
P	14	13.5	15	17.5	16	23
Q	19	22	25	32	40	44
R	2	2	2	4	4	4
S	155	163	180.4	220	252	306
T	15.2°	13.0°	14.3°	14.3°	14.0°	13.7°
V	7	9	9	9	11	14
W	11	14	14	14	17.5	20
X	1/8	1/8	1/4	1/4	3/8	3/8
Y	4.6	10.5	9.4	8.5	10	9.2
AA	68	74	85	100	118	147
AB	16	18	22	26	34	40
AC	8	9	11	13	17	20
AD	8	9	11	13	17	20
Ad	8	8	10	12	16	18
AE	10	10	12	16	20	24
AF	6	7	9	10	13	16
AH	20	22	26	32	40	46
AJ	4.5	4.5	6	6.6	9	11
AK	8	8	9.5	11	14	17.5
AL	4.4	4.4	6	7	8.6	11
AO	9	10	12	16	20	24
CA	14	14	16	20	25	28
CB	10	10	12	16	20	24
CC	10	10	12	13	18	24
CD	10	10	10	15	20	25
CE	M4	M4	M5	M6	M8	M10
CF	6	6	6	7	9	12

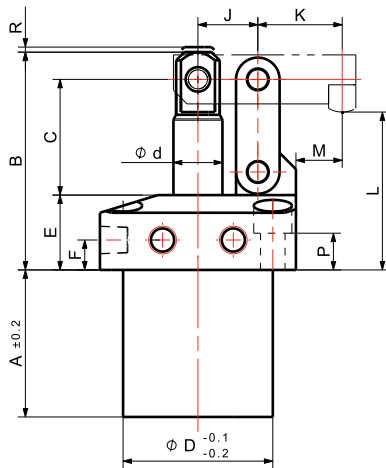
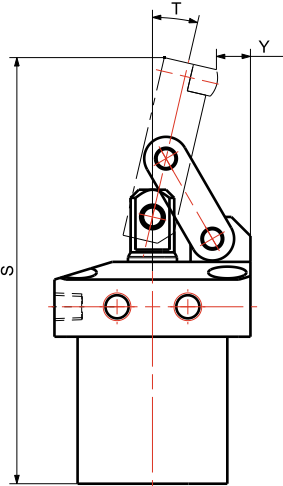

LEVER (OPTION)

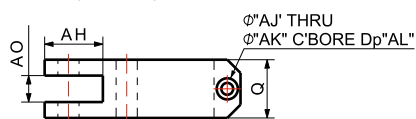

PAD (OPTION)

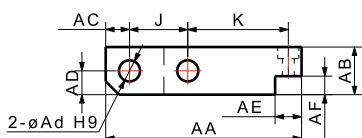
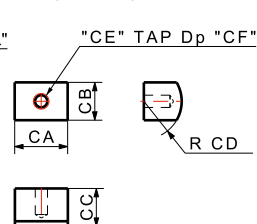

Hinge(Link) Clamp Double Rod Type

Features

- | | |
|---|---|
| 1. 리미트 센서 시스템에 적용 | 1. Applicable to limit sensor system |
| 2. 쉬운 설치와 배관 | 2. Easy installation and piping |
| 3. 편리한 제품 장탈착 | 3. Easy loading and removal of workpiece |
| 4. 내경범위 : $\phi 25 \sim 80$ | 4. Piston Diameter : $\phi 25 \sim 80$ |
| 5. 작동압력 : $15 \sim 150 \text{kgf/cm}^2$ | 5. Operating Pressure : $15 \sim 150 \text{kgf/cm}^2$ |
| 6. 사용온도 : $0 \sim 60^\circ\text{C}$ | 6. Operating Temperature : $0 \sim 60^\circ\text{C}$ |
| 7. 레버는 옵션 | 7. Lever is option item |

> HGC - 25 02 D

① ② ③

① Piston Diameter(mm) ② Clamping Force at 70kgf/cm^2 ③ Double Rod Type

Piping Method

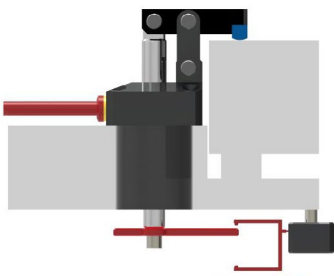

P : Clamp
R : Unclamp

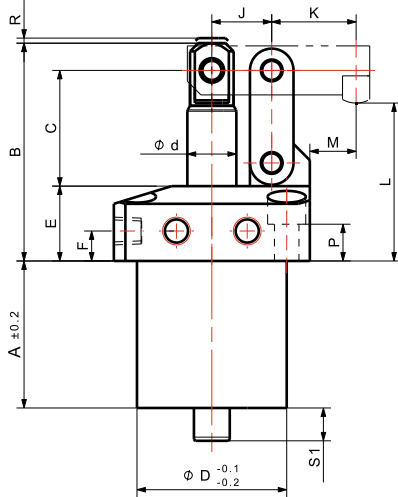
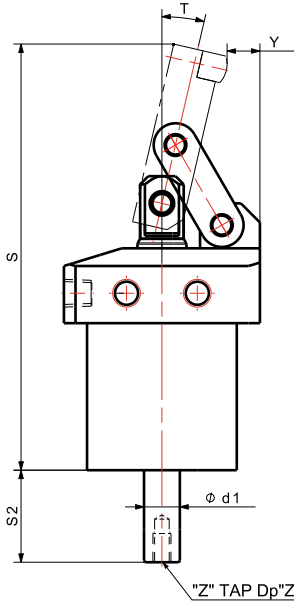
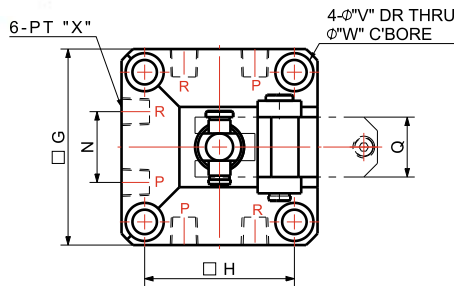

LEVER (OPTION)

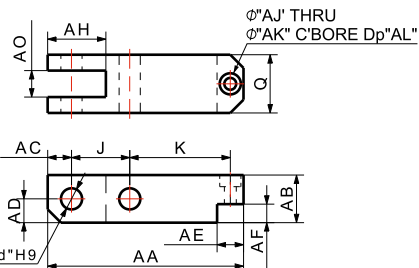

PAD (OPTION)

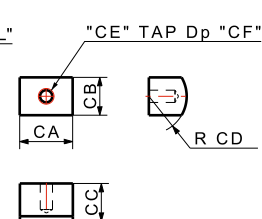

Dimensions

MODEL NO.	HGC-2502D	HGC-3203D	HGC-4005D	HGC-5009D	HGC-6315D	HGC-8023D
A	54	57	60	78	89	100
B	75	80	90	108	127	158
C	39	42.5	47.5	57.5	71	86
φD	48	55	65	80	95	115
φd	16	18	25	30	35.5	45
φd1	14	16	16	20	20	20
E	28	27.5	29.0	34.5	36	48
F	11	11	12	14	14	22.5
G	62	72	80	88	108	125
H	47	55	63	70	85	100
J	22	22	26	32	38	46
K	33	38	42	47	53	69
L	55	58	63	76	85	108
M	24	24	28	35	37	52.5
N	24	26	31	33	39	46
P	14	13.5	15.5	17.5	16	23
Q	19	22	25	32	40	44
R	2	2	2	4	4	4
S	155	166.4	180.4	220	252	306
S1	12	12	12	14	14	14
S2	38	38	43	52	60	70
T	15.2°	13.1°	14.3°	14.3°	14.0°	13.7°
V	7	9	9	9	11	14
W	11	14	14	14	17.5	20
X	1/8	1/8	1/4	1/4	3/8	3/8
Y	4.6	10.5	9.4	8.5	10	9.2
Z	M8	M8	M8	M12	M12	M12
Z1	12	15	15	20	20	20
AA	68	74	85	100	118	147
AB	16	18	22	26	34	40
AC	8	9	11	13	17	20
AD	8	9	11	13	17	20
Ad	8	8	10	12	16	18
AE	10	10	12	16	20	24
AF	6	7	9	10	13	16
AH	20	22	26	32	40	46
AJ	4.5	4.5	6	6.6	9	11
AK	8	8	9.5	11	14	17.5
AL	4.4	4.4	6	7	8.6	11
AO	9	10	12	16	20	24
CA	14	14	16	20	25	28
CB	10	10	12	16	20	24
CC	10	10	12	13	18	24
CD	10	10	10	15	20	25
CE	M4	M4	M5	M6	M8	M10
CF	6	6	6	7	9	12



Hinge(Link) Clamp Tube Type

Features

- | | |
|--|--|
| 1. 하우징 하부 배관 | 1. Piping on lower position of housing |
| 2. 쉬운 설치와 배관 | 2. Easy installation and piping |
| 3. 편리한 제품 장탈착 | 3. Easy loading and removal of workpiece |
| 4. 내경범위 : $\phi 25 \sim 80$ | 4. Piston Diameter : $\phi 25 \sim 80$ |
| 5. 작동압력 : $15 \sim 70 \text{kgf/cm}^2$ | 5. Operating Pressure : $15 \sim 70 \text{kgf/cm}^2$ |
| 6. 사용온도 : $0 \sim 60^\circ\text{C}$ | 6. Operating Temperature : $0 \sim 60^\circ\text{C}$ |
| 7. 레버는 옵션 | 7. Lever is option item |

> HGC - 25 02 T
① ② ③

① Piston Diameter(mm) ② Clamping Force at 70kgf/cm^2 ③ Tube Type

Piping Method

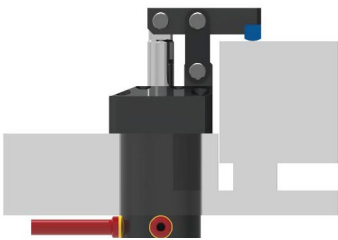

Dimensions

MODEL NO.	HGC-2502T	HGC-3203T	HGC-4005T	HGC-5009T	HGC-6315T	HGC-8023T
A	64	64	79	94	111	123
B	75	80	90	108	127	158
C	39	42.5	47.5	57.5	71	86
ϕD	48	55	65	80	95	115
ϕd	16	18	25	30	35.5	45
E	28(TV:30)	27.5	29.0	34.5	36	48
F	8	8	11	12	14	15.5
G	62	72	80	88	108	125
H	47	55	63	70	85	100
J	22	22	26	32	38	46
K	33	38	42	47	53	69
L	55(TV:57)	58	63	76	85	108
M	24	24	28	35	37	52.5
P	14	13.5	15	17.5	16	23
Q	19	22	25	32	40	44
R	2	2	2	4	4	4
S	155	163	180.4	220	252	306
T	15.2°	13.0°	14.3°	14.3°	14.0°	13.7°
V	7	9	9	9	11	14
W	11	14	14	14	17.5	20
X	1/8	1/8	1/4	1/4	3/8	3/8
Y	4.6	10.5	9.4	8.5	10	9.2
AA	68	74	85	100	118	147
AB	16	18	22	26	34	40
AC	8	9	11	13	17	20
AD	8	9	11	13	17	20
Ad	8	8	10	12	16	18
AE	10	10	12	16	20	24
AF	6	7	9	10	13	16
AH	20	22	26	32	40	46
AJ	4.5	4.5	6	6.6	9	11
AK	8	8	9.5	11	14	17.5
AL	4.4	4.4	6	7	8.6	11
AO	9	10	12	16	20	24
CA	14	14	16	20	25	28
CB	10	10	12	16	20	24
CC	10	10	12	13	18	22
CD	10	10	10	15	20	25
CE	M4	M4	M5	M6	M8	M10
CF	6	6	6	7	9	12

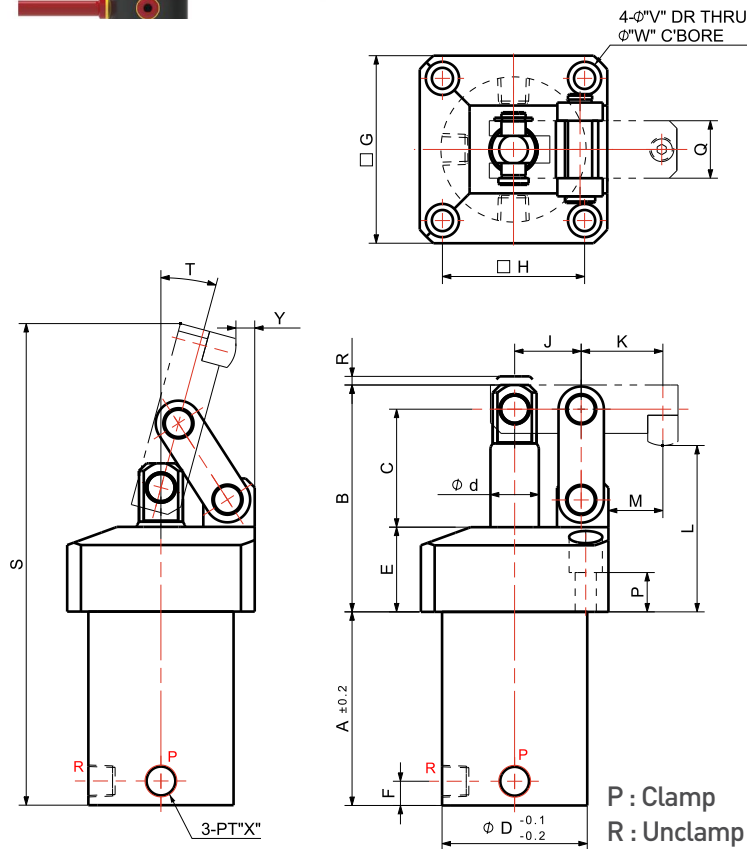

LEVER (OPTION)



PAD (OPTION)

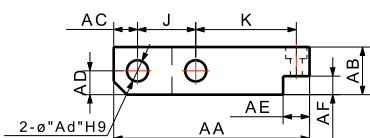
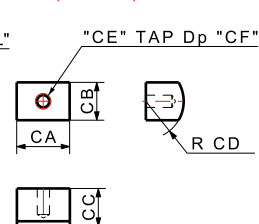



Hinge(Link) Clamp TV & TS Type

Features

- | | |
|--|--|
| 1. 하우징 밀면 배관 | 1. Piping on lower position of housing |
| 2. 플랜지 상면 밸브 장착(TV) | 2. Valve located on the top of flange |
| 3. 편리한 제품 장탈착 | 3. Easy loading and removal of workpiece |
| 4. 내경범위 : $\varnothing 25 \sim 40$ | 4. Piston Diameter : $\varnothing 25 \sim 40$ |
| 5. 작동압력 : $15 \sim 70 \text{kgf/cm}^2$ | 5. Operating Pressure : $15 \sim 70 \text{kgf/cm}^2$ |
| 6. 사용온도 : $0 \sim 60^\circ\text{C}$ | 6. Operating Temperature : $0 \sim 60^\circ\text{C}$ |
| 7. 레버는 옵션 | 7. Lever is option item |

> HGC - 25 02 TV

- ① Piston Diameter(mm)
 ② Clamping Force at 70kgf/cm^2
 ③ Bottom Tube + Valve Type

HGC - 25 02 TS

- ① Piston Diameter(mm)
 ② Clamping Force at 70kgf/cm^2
 ③ Bottom Tube Type

TV Type

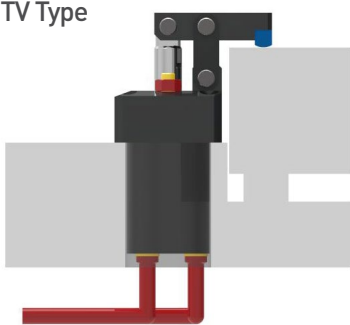

TS Type

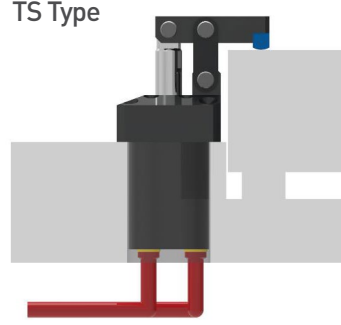

Dimensions

MODEL NO.	HGC-2502TV	HGC-3203TV	HGC-4005TV
DIMENSIONS (mm)	BA	8.5	8
	BB	13.5	13
	BD	15	18.5
	BE	15	18.5
	BF	18	21.5
	X	1/8	1/8

MODEL NO.	HGC-2502TS	HGC-3203TS	HGC-4005TS
DIMENSIONS (mm)	BJ	21	23
	BK	12	20
	X	1/8	1/8

TV Type

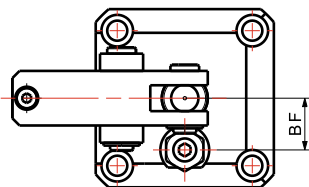

TS Type

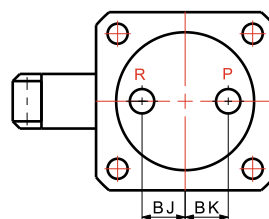
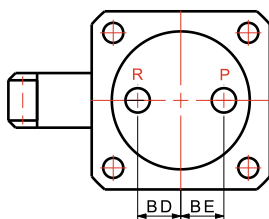
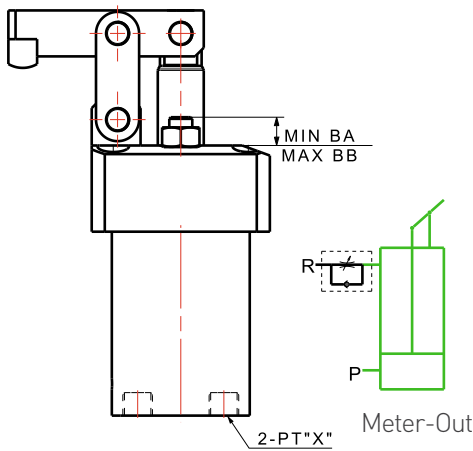
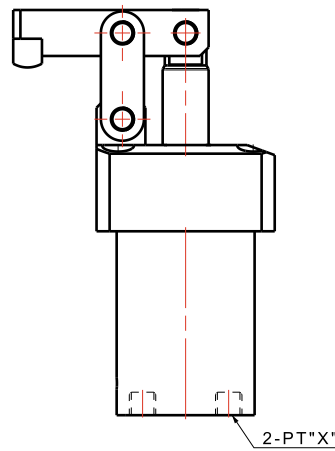

Mounting Detail

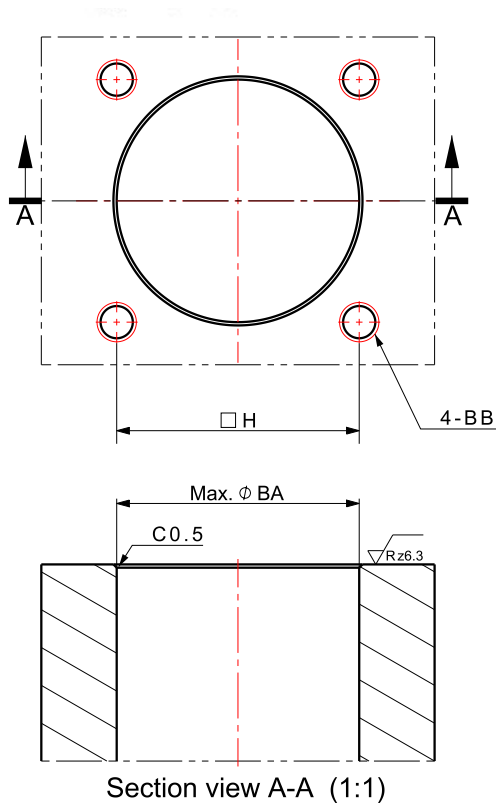

Dimensions

	MODEL NO.	H	ØBA	BB
DIMENSIONS (mm)	HGC-2502	47.0	49.0	M6
	HGC-3203	55.0	56.0	M8
	HGC-4005	63.0	66.0	M8
	HGC-5009	70.0	81.0	M8
	HGC-6315	85.0	96.0	M10
	HGC-8023	100.0	116.0	M12

설계시 주의 사항 Cautions for design

1. 사용 압력 범위는 15~150kgf/cm² 입니다.
(단, Compact Type과 Tube, TV, TS Type은 70kgf/cm² 이하에서만 사용)

The range of operating pressure is 15~150 kgf/cm².
[But, Compact, T, TV and TS types, use only under 70 kgf/cm²]

2. 그림에서 K가 J에 비하여 현격하게 짧을 때는 최고 사용 압력을 기준으로 비율에 맞춰 공급압력을 낮춰 주십시오.

As shown in the figure, when K is significantly shorter than J, the operating pressure should be lowered in proportion to the maximum working pressure.

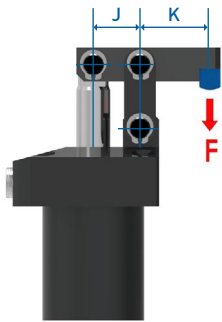

3. 클램프 할 때 레버가 취부면과 평행이 되도록 높이를 조절해서 클램핑 해 주십시오. (허용각도 ±3°)

When clamping, adjust the height to ensure the lever is parallel to the mounting surface. [Tolerance : ±3°]

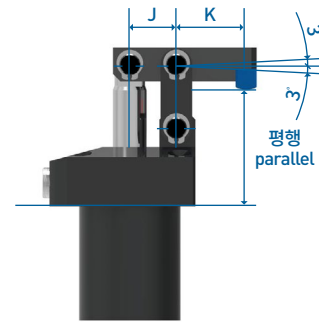

4. 피스톤 로드에는 축 방향 이외의 힘이 걸리지 않도록 하십시오.

Do not apply force to the piston rod other than in the axial direction.

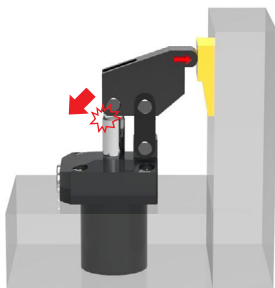

5. 경사면을 클램핑 할 때 클램프를 경사면과 평행이 되도록 설치 하십시오.

When clamping a slope, make sure the clamp surface is parallel to the slope.

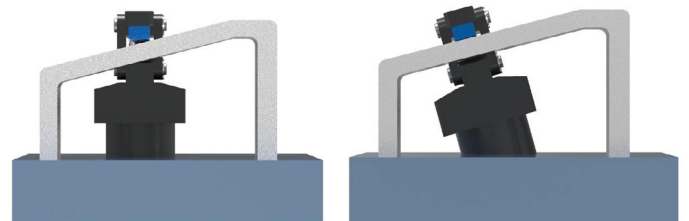

6. 용접지그 등에 사용할 때는 스파터(spatter)가 로드에는 달라 붙지 않게 조치하십시오.

When using on a welding jig, ensure the spatter does not stick to the rod.

설치시 주의사항 Cautions for installation

1. 유압유는 KIXX RD HD 32(GS 칼텍스-ISO VG 32)또는 동급을 사용하십시오.
Use hydraulic oil KIXX RD HD 32(GS Caltex-ISO VG 32) or equivalent.

3. 배관 후 초기에는 관로 내에 공기가 들어 있으므로 에어빼기를 하신 후 사용하십시오.
Air in the pipe or manifold must be removed before using it.

5. 테프론 테이프는 아래 그림과 같이 니플의 나사산을 1~2산 남겨 놓고 감아 주십시오.
As shown in the figure below, teflon tape should be wound, leaving one or two threads of the nipple.

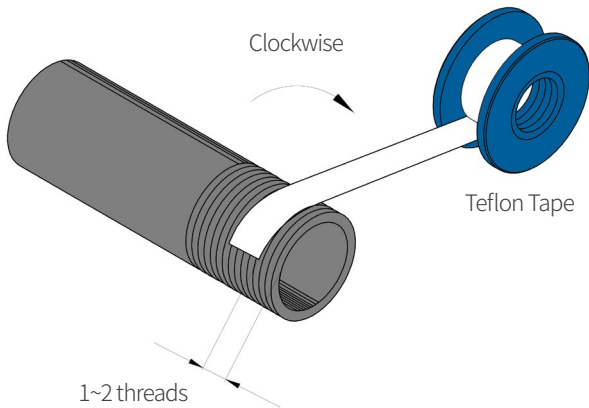

2. 배관 전에 파이프, 니플, 지그의 유로 등은 철저히 버(BURR)를 제거하고 깨끗이 청소한 후 사용하십시오.
Before piping, remove burr thoroughly and clean flow channels of pipe, nipple and jig.

4. 회로 안의 에어빼기를 한 후 속도 조정을 하십시오.
After removing air in the circuit, please adjust speed.

6. 힌지클램프의 취부는 강도 구분 12.9 볼트를 사용하고, 아래의 권장체결토크표를 참고로 체결해 주십시오.
Use bolts with ISO 898-1 class 12.9 to mount hinge clamp and tighten with reference to the recommended tightening torque table below.

[취부볼트 권장체결토크 (강도 구분 12.9)]

[Recommended screwing torque for attachment bolt(ISO 898-1 class)]

Bolt size	Torque
M4 x 0.7	29 kgf.cm
M5 x 0.8	71 kgf.cm
M6 x 1	112 kgf.cm
M8 x 1.25	255 kgf.cm
M10 x 1.5	499 kgf.cm
M12 x 1.75	612 kgf.cm

1kgf.cm = 0.0981N.m

취급시 주의사항 Cautions for operation

1. 완벽하게 안전이 확보 되었다고 확신이 왔을 때 전원을 차단하고 수리 점검 작업에 들어 가십시오.
When you are confident of safety, turn off the power and start troubleshooting.

3. 제품을 분해 또는 개조를 하면 보증기간 내에 있어도 보증수리가 불가하며, 내부 부품이 변형 또는 분실될 수 있습니다.
The product warranty will be void in cases of product modification or disassembly. Doing so may deform or lose internal parts.

5. 유압유의 상태를 정기적으로 확인하십시오.
Please check hydraulic oil regularly.

7. 공압용 클램프 사용시 유입되는 수분은 제품의 부식, 겨울철 동결로 성능저하 및 고장의 주요 원인이 될 수 있으므로 수분제거기를 필히 사용하십시오.
Moisture entering during pneumatic clamp operation can be a major cause of failure and performance decrease due to corrosion and freezing in winter.

2. 힌지클램프 작동 중 클램프 동작 범위 내에 신체를 넣지 마십시오.
Care should be taken to stay well clear of the clamping range during hinge clamp operation.

4. 고정된 부품들이 느슨한지 점검해 주십시오.
Check if all parts are fastened.

6. 장기간 가동하지 않았던 장비는 사전에 정상 작동을 확인하십시오.
The performance of equipment should be checked in advance in cases of extended downtime.

8. 피스톤 로드 주변을 정기적으로 청소하여 항상 청결을 유지하십시오.
Clean the area around the piston rod as part of regular maintenance.

Swing Clamp Introduction

스윙 클램프는 실린더 내부 리드 홈에 의해 회전 후 직진하도록 디자인된 제품으로 공작물을 로딩 / 언로딩할 때 간섭을 쉽게 회피하고 컴팩트한 사이즈는 설계자의 설계편의성을 최대로 고려한 디자인입니다. 클램프력이 공작물에 수직방향으로 작용하므로 안정된 클램프를 할 수 있습니다. 설치상황에 가장 적합한 제품을 선정할 수 있도록 다양한 타입과 사이즈가 있습니다.

Swing clamp is designed to straighten after being rotated by the led groove inside the cylinder.
Swing clamp dodges interference when loading a structure and its compact size is intended to maximize design convenience for the designer.
Clamping force is applied to a structure in a vertical direction to ensure stable clamping.
The products are available in various types and sizes to suit your installation environment.



Operation

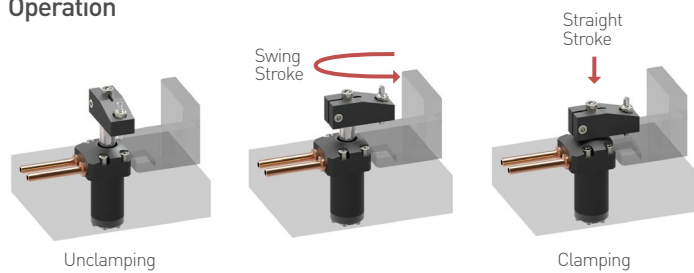

Installation

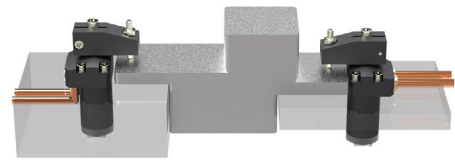

Swing direction (SDR & SDL)

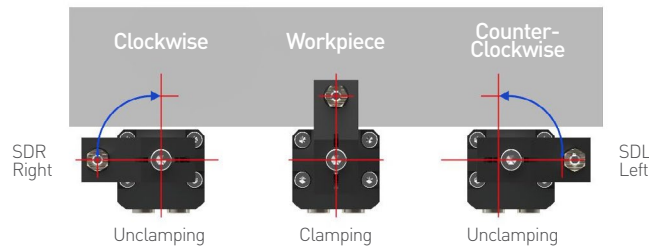

Clamp 높이 선정 방법

How to choose clamp height

반드시 직선 스트로크 구간 내에서 클램핑이 이루어지도록 설치해야 하며 가능한 언클램핑시 A의 치수를 아래 공식에 의해 세팅한다.

$$A = \text{Swing Stroke} + \text{Straight Stroke} - 2\text{mm}$$

Swing clamp must be installed to ensure clamping occurs within the straight stroke section. If possible, the dimension of A should be set by the following formula

$$A = \text{Swing Stroke} + \text{Straight Stroke} - 2\text{mm}$$

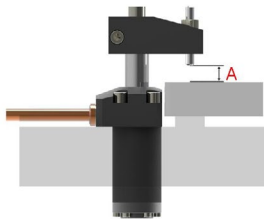

레버 고정시 주의 사항

Cautions for fixing lever

1. 레버를 고정할 때, 그림과 같이 클램핑한 위치에 렌치볼트, 'A'를 먼저 체결한다.
2. 렌치볼트(Wrench Bolt), 'B'를 살짝 체결한다. 그렇지 않으면 실린더핀 (Cylinder Pin)이 파손되므로 제품의 사용이 불가능하다. ('B'를 체결시 레버를 바이스 혹은 몽키스패너로 고정해야 한다) 위의 사항을 지키지 않아 생기는 손상에 대해서는 책임을 지지 않는다.

1. When fastening a lever, fasten the wrench bolt 'A' first on the clamped position as shown in figure.
2. Fasten lightly the wrench bolt 'B'. Otherwise, the product may be unusable due to cylinder pin damage. (When tightening 'B', the lever must be fixed with a vise or spanner.) We are not responsible for damage caused by failure to comply with the instructions aforementioned.

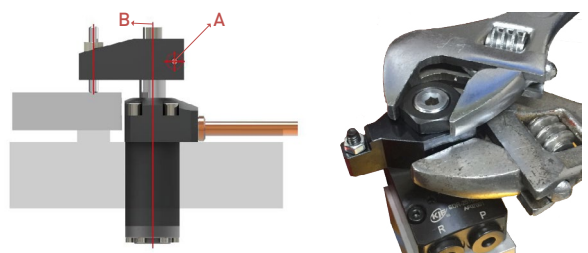

권고사항(106 페이지)을 반드시 숙지하십시오!
Please be well informed of Recommendations(Page 102).

Swing Clamp Applications

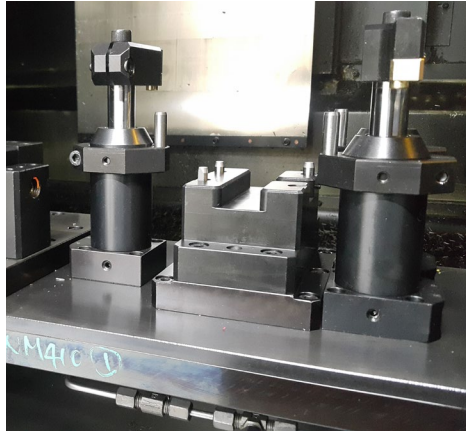
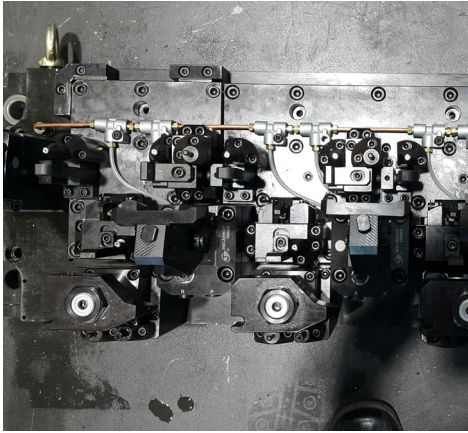

Swing Clamp Line Up



Cartridge Type
Model No. RSD□-□C

고압용/초소형사이즈
High Pressure
Subminiature Size

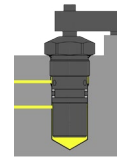

Compact Type
Model No. CSD□-□G

저압용/3종 로드타입
Low Pressure
Three Rod Types

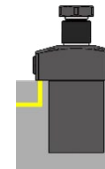

Bottom Flange Type
Model No. SD□-□F□

고압용/하부 배관방식
High Pressure
Bottom Piping Method

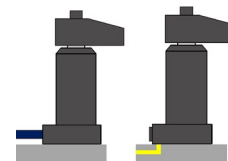

Top Flange Type
Model No. SD□-□

고압용/상부 배관방식
High Pressure
Top Piping Method

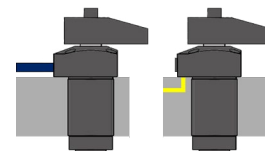

Model No. Explanation

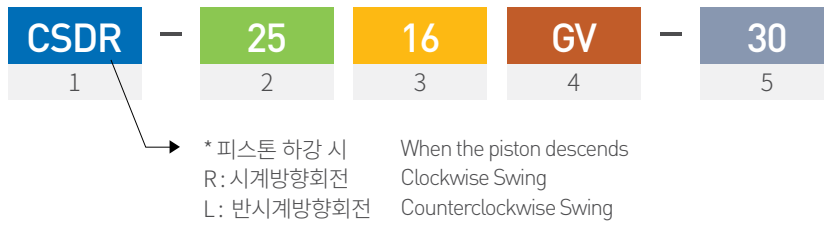

1 Clamp Type

RSD□: Swing Clamp(Cartridge Type/High Pressure)

CSD□: Compact Swing Clamp(Low Pressure)

SD□: Swing Clamp(High Pressure)

2 Cylinder Inner Diameter(∅)

RSD□
 10 = 10mm
 14 = 14mm

CSD□
 25 = 25mm
 30 = 30mm
 36 = 36mm
 42 = 42mm
 50 = 50mm
 60 = 60mm

SD□
 25 = 25mm
 32 = 32mm
 40 = 40mm
 55 = 55mm

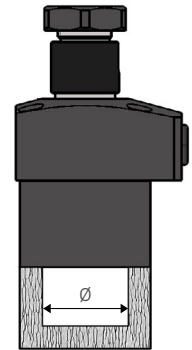

3 Piston Rod Stroke

RSD□
 18 = 18mm
 16 = 16mm

CSD□
 16 = 16mm
 17 = 17mm
 18 = 18mm
 20 = 20mm
 26 = 26mm
 28 = 28mm

SD□
 22 = 22mm
 30 = 30mm
 45 = 45mm
 55 = 55mm

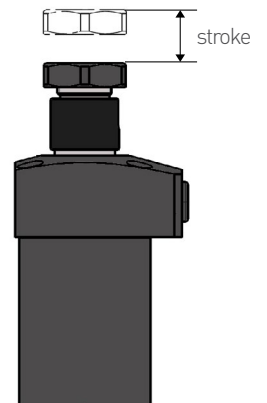

4 Piping Method & Function Type

No sign: Nipple Piping

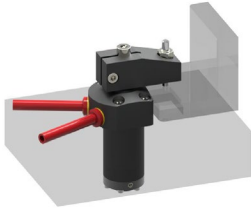

C : Cartridge Piping

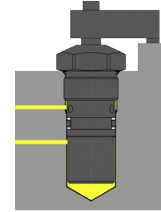

G : Manifold Piping

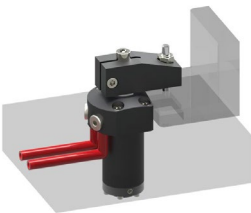

GV : Manifold Piping + Flow Control Valve



F : Bottom Nipple Piping



FG : Bottom Gaket Piping



FGV : Bottom Gaket Piping + Flow Control Valve



FGT : Bottom Gaket Top Piping

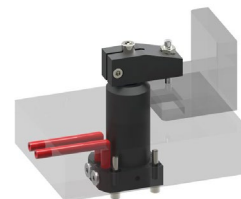

P : Pin Hole Piston Rod



5 Swing Angle

No sign: 90°

90도: 표준사양
그외 각도: 주문제작
ex) 30 = 30°

90 degree: Standard Spec.
Other angles: Customized Design
ex) 30 = 30°

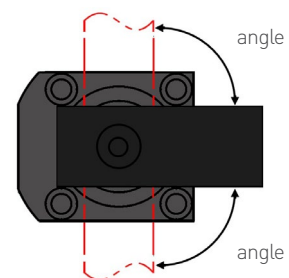

Swing Clamp Cartridge Type

Application

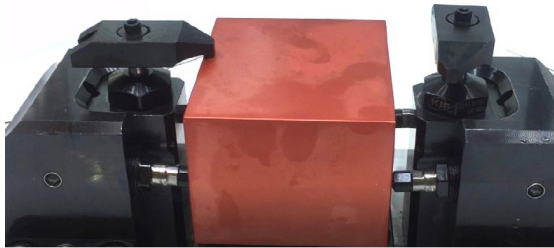

Cartridge Method

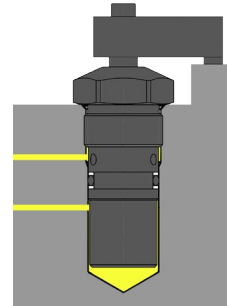

Model No.

RSDR-1018C



- 1** Swing Direction
For Clamping
SDR = Clockwise (시계방향)
SDL = Counter-Clockwise (반시계방향)
- 2** Piston Diameter
ex) 10 = $\phi 10$
- 3** Piston Rod Stroke
ex) 18 = 18
- 4** Type
> C = Cartridge
- 5** Swing Angle
No sign = 90°
ex) 30 = 30°

Specification

MODEL NO.		RSDR/L-1018C	RSDR/L-1416C
Weight (kg)		0.12	0.29
Clamping Cylinder Force (kgf) at 70kgf/cm ²		35	53
Piston Diameter (mm)		10	14
Effective Area (cm ²)		0.5	0.75
Stroke (mm)	Swing	10	8
	Straight	8	8
	Total	18	16
Oil Capacity (cm ³)	At Clamping	0.9	1.2
Swing Angle(Repeated Accuracy) Tolerance		$\pm 2^\circ (\pm 0.5^\circ)$	
Operating Pressure Range		15 ~ 150 kgf/cm ²	
Operating Temperature Range		0 ~ 60°C	

Swing Clamp Cartridge Type



Features

- | | |
|--|--|
| 1. 초소형 사이즈 | 1. Subminiature size |
| 2. 편리한 유로설계 | 2. Easy oil path design |
| 3. 견고한 스윙 메커니즘 | 3. Sturdy swing mechanism |
| 4. 내경범위 : $\phi 10 \sim 14$ | 4. Piston Diameter : $\phi 10 \sim 14$ |
| 5. 작동압력 : $15 \sim 150 \text{ kgf/cm}^2$ | 5. Operating Pressure : $15 \sim 150 \text{ kgf/cm}^2$ |
| 6. 사용온도 : $0 \sim 60^\circ\text{C}$ | 6. Operating Temperature : $0 \sim 60^\circ\text{C}$ |
| 7. 레버 조립 시 고정 상태에서 볼트 체결 | 7. When assembling the lever, the bolts should be fastened in a fixed state. |
| 8. 레버는 옵션 사항임 | 8. Lever is option item |

> RSDL - 10 18 C
① ② ③ ④

① R=Right, L=Left ② Piston Diameter(mm)
③ Total Stroke(mm) ④ Cartridge Type

> RSDx-1018C

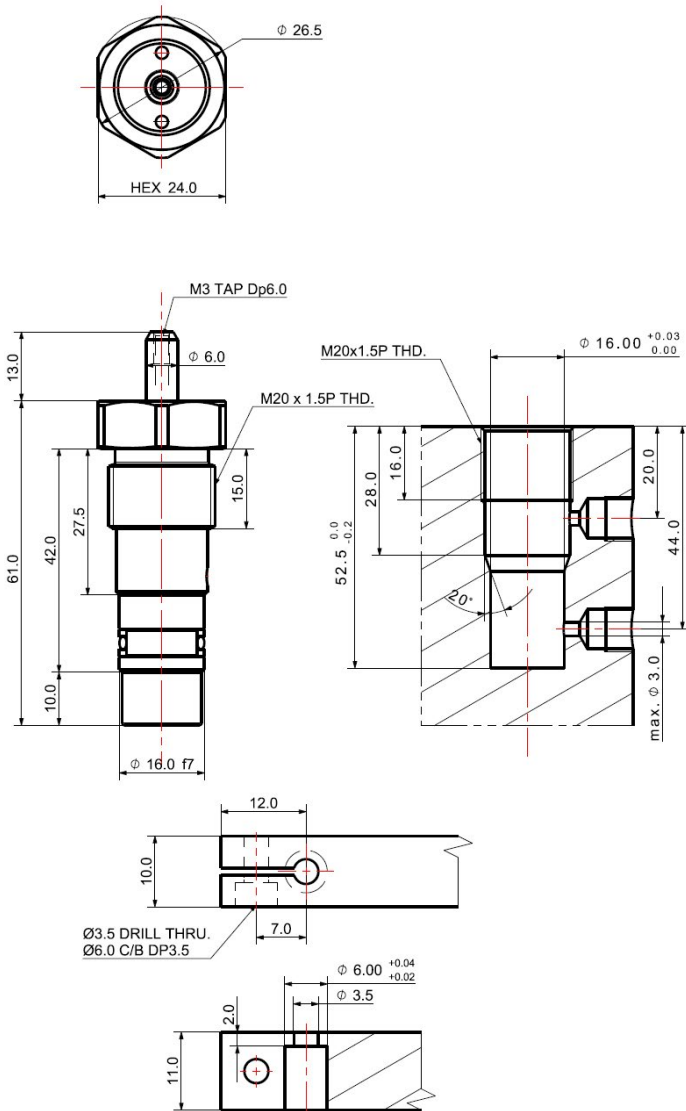

> RSDx-1416C

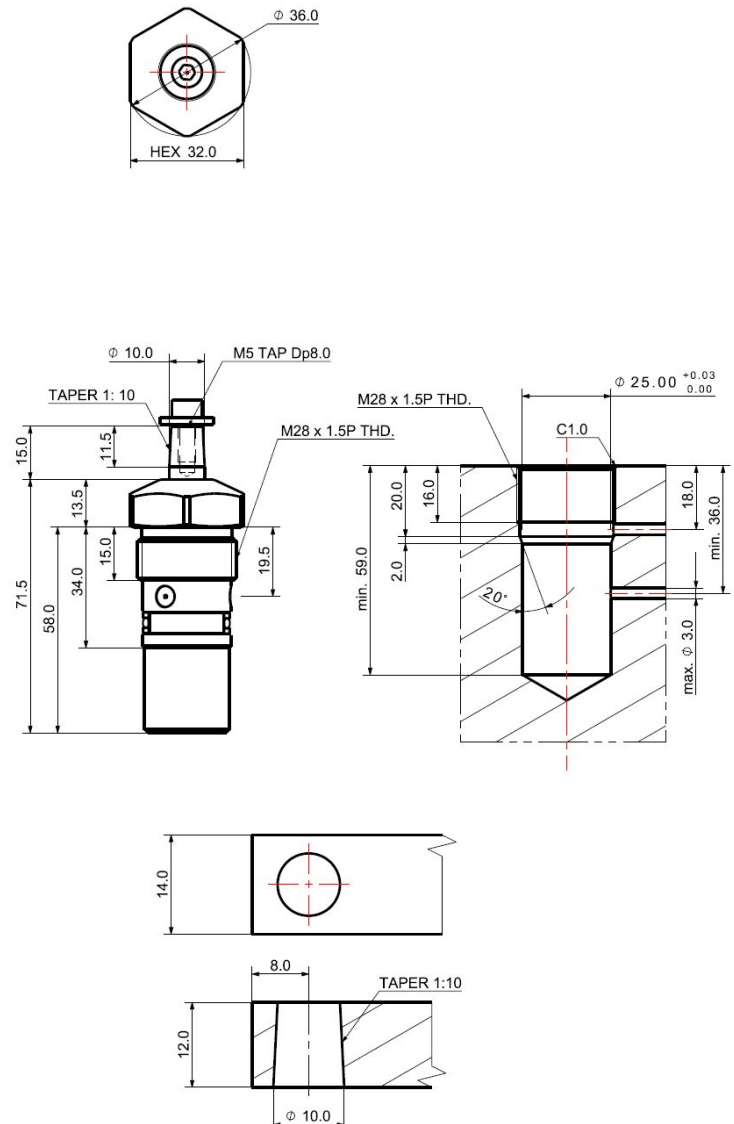

Compact Swing Clamp (Low Pressure)

Compact type vs Gasket type

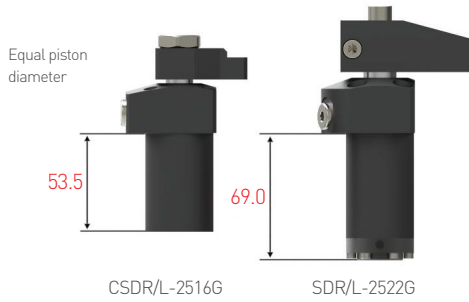

Manifold Method

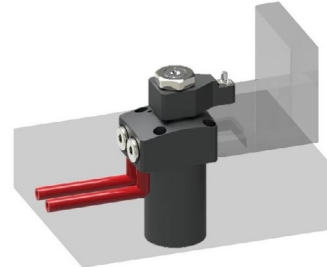

Rod Types



Model No.

CSDR-2516GV



1 Swing Direction
For Clamping
SDR = Clockwise (시계방향)
SDL = Counter-Clockwise (반시계방향)

2 Piston Diameter
ex) 25 = $\varnothing 25$

3 Piston Rod Stroke
ex) 16 = 16mm

4 Type

- > G = Gasket
- > GV = Gasket + Flow control valve
- > GP = Gasket + Pin Hole
- > GPV = Gasket + Pin Hole + Flow Control Valve
- > GQ = Gasket + Quick Change
- > GQV = Gasket + Quick Change + Flow Control Valve

5 Swing Angle
No sign = 90°
ex) 30 = 30°

* V: meter-in valve W: meter-out valve

Specification

MODEL NO.		CSDR / L-2516 □			CSDR / L-3017 □			CSDR / L-3618 □			CSDR / L-4220 □			CSDR / L-5026 □			CSDR / L-6028 □		
Type	Gasket	G	GP	GQ	G	GP	GQ	G	GP	GQ	G	GP	GQ	G	GP	GQ	G	GP	GQ
		GV	GPV	GQV	GV	GPV	GQV	GV	GPV	GQV	GV	GPV	GQV	GV	GPV	GQV	GV	GPV	GQV
Weight (kg)		0.90	0.73	0.75	1.33	1.05	1.09	1.52	1.36	1.44	1.78	1.66	1.76	3.21	3.01	3.19	5.80	4.28	4.41
		0.92	0.75	0.76	1.35	1.07	1.09	1.83	1.38	1.42	1.80	1.68	1.74	3.25	3.05	3.15	5.81	4.29	4.42
Clamping Cylinder Force (kgf) at 70kgf/cm ²		219			316			446			625			879			1,305		
Piston Diameter (mm)		ø25			ø30			ø36			ø42			ø50			ø60		
Effective Area (cm ²)		3.14			4.52			6.37			8.94			12.56			18.64		
Stroke (mm)	Swing	8			9			10			10			16			16		
	Straight	8			8			8			10			10			12		
	Total	16			17			18			20			26			28		
Oil Capacity (cm ³)	At Clamping	5.02			7.69			11.47			17.88			32.66			52.20		
Swing Angle (Repeated Accuracy) Tolerance		±3° (±0.5°)																	
Operating Pressure Range		20 ~ 70 kgf/cm ²																	
Operating Temperature Range		0 ~ 60°C																	

Air Sensor Type

클램프와 언클램프 감지용 에어센서 타입은 주문제작으로 공급해드립니다. 문의 바랍니다.

Air Sensor type for detecting clamp and unclamp is able to be provided as customized design. Please contact us.

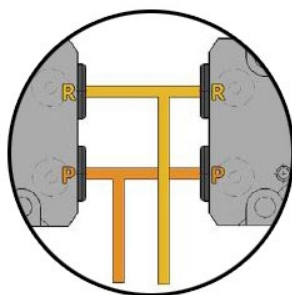
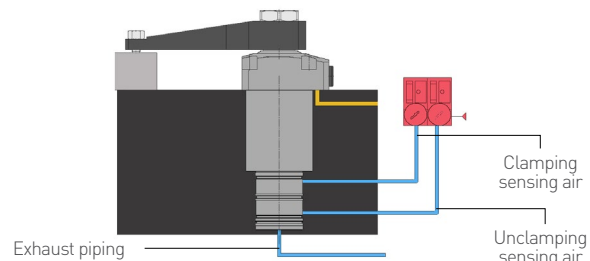

포트대칭방향 **Port Symmetry Direction** (주문제작)

- * 위의 구성으로 설치 시 유로구성의 편의성 제공
- * Providing convenience of making oil path



GV type 주문 가능합니다.
GV type is available.

P : Clamp
R : Unclamp

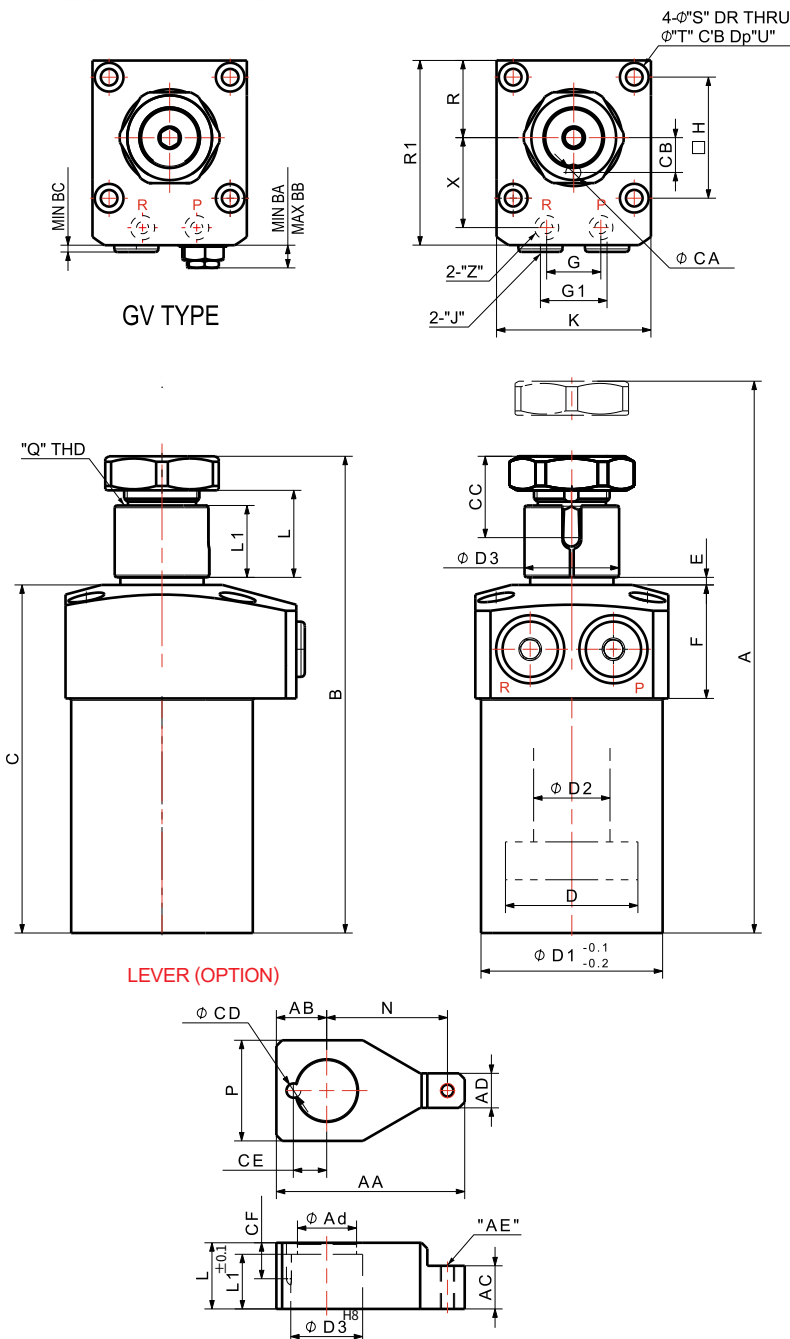

Compact Swing Clamp G / GV Type (Standard Rod)

Features

1. 콤팩트 디자인
 2. 레버 교환 가능
 3. 가스연질화 표면처리
 4. 내경범위 : $\phi 25\sim 60$
 5. 작동압력 : $20\sim 70\text{kgf/cm}^2$
 6. 사용온도 : $0\sim 60^\circ\text{C}$
 7. 레버 조립 시 고정 상태에서 볼트 체결
 8. 레버는 옵션 사항임
1. Compact design
 2. Lever exchangeable
 3. Gas Nitriding Surface
 4. Piston Diameter : $\phi 25\sim 60$
 5. Operating Pressure : $20\sim 70\text{kgf/cm}^2$
 6. Operating Temperature : $0\sim 60^\circ\text{C}$
 7. When assembling the lever, the bolts should be fastened in a fixed state.
 8. Lever is option item

> CSDR - 25 16 G

CSDR - 25 16 GV

① ② ③ ④

① ② ③ ④

- ① R=Right, L=Left ② Piston Diameter (mm) ③ Total Stroke(mm)
④ G=Gasket / GV=Gasket+Side Valve Type

Dimensions

MODEL NO.	CSDR/L-2516G	CSDR/L-3017G	CSDR/L-3618G	CSDR/L-4220G	CSDR/L-5026G	CSDR/L-6028G
A	122.5	134	144	146	182.5	198
B	106.5	117	126	126	156.5	170
C	80.5	88	92	88	114.5	122
ϕD	25	30	36	42	50	60
$\phi D1$	37	42	48	55	65	75
$\phi D2$	15	18	22	25	30	35
$\phi D3$	17	20	25	28	34	40
E	2	2	2	2	2	2
F	27	30	30	28	31	37
G	16	18	22	24	30	32
G1	18	21	22	24	30	32
H	31.5	36	40	47	55	63
J	G1/8	G1/8	G1/8	G1/8	G1/4	G1/4
K	40	47	51	60	70	80
L	17	19	23	26	29	35
L1	14	16	19	22	25	31
N	32	36.5	42	50	57	65
P	26	28	35	38	50	58
Q	M14x1.5P	M16x1.5P	M20x1.5P	M22x1.5P	M27x1.5P	M28x1.5P
R	20	23.5	25.5	30	35	40
R1	49	56	61	69	81	92
S	4.5	5.5	5.5	6.8	6.8	9
T	8	9.5	9.5	11	11	14
U	7	12	11	11.5	13	16
X	23.5	26	30	33.5	39.5	45
Z	P5-1B	P5-1B	P5-1B	P5-1B	P7-1B	P7-1B
AA	50	56.5	65.5	77	92	105
AB	13	14	17.5	19	25	29
AC	12	13	15	15	15	20
AD	10	12	12	17	20	22
ϕAd	15	17	21	23.5	29	33
AE	M5	M6	M6	M8	M10	M12
BA	7.1	7.1	6.6	7.1	7.65	7.15
BB	13.7	13.7	13.2	13.7	17.25	16.75
BC	3.9	3.9	3.4	3.9	3.8	3.3
ϕCA	4	4	5	6	6	8
CB	8	9	11.5	13	15.5	18
CC	17.4	18.5	21.5	24.5	27.5	28.5
ϕCD	4	4	5	6	6	8
CE	8	9	11.5	13	15.5	18
CF	10.4	10.5	12.5	14.5	16.5	17.5



Compact Swing Clamp GP / GPV Type (Pin Hole Rod)

Features

1. 핀 홀 로드형
 2. 천칭 레버 적용형
 3. 내경범위 : $\phi 25\sim 60$
 4. 작동압력 : $20\sim 70\text{kgf/cm}^2$
 5. 사용온도 : $0\sim 60^\circ\text{C}$
 6. 레버는 옵션 사항임
1. Pin hole rod type
 2. Balance lever application type
 3. Piston Diameter : $\phi 25\sim 60$
 4. Operating Pressure : $20\sim 70\text{kgf/cm}^2$
 5. Operating Temperature : $0\sim 60^\circ\text{C}$
 6. Lever is option item

> CSDR - 25 16 GP

CSDR - 25 16 GPV

① ② ③ ④

① ② ③ ④

① R=Right, L=Left ② Piston Diameter (mm) ③ Total Stroke(mm)

④ GP = Gasket + Pin Hole / GPV = Gasket + Pin Hole + Side Valve Type

GPV type 주문 가능합니다.
GPV type is available.

P : Clamp
R : Unclamp

Dimensions

MODEL NO.	CSDR/L-2516GP	CSDR/L-3017GP	CSDR/L-3618GP	CSDR/L-4220GP	CSDR/L-5026GP	CSDR/L-6028GP
A	120.5	132	142	144	183.5	198
B	104.5	115	124	124	157.5	170
C	80.5	88	92	88	114.5	122
ϕD	25	30	36	42	50	60
$\phi D1$	37	42	48	55	65	75
$\phi D2$	15	18	22	25	30	35
$\phi D3$	13.5	16	20	23	28	33.5
E	24	27	32	36	43	48
F	27	30	30	28	31	37
G	16	18	22	24	30	32
G1	18	21	22	24	30	32
H	31.5	36	40	47	55	63
J	G1/8	G1/8	G1/8	G1/8	G1/4	G1/4
K	40	47	51	60	70	80
L	21	24	27.5	31.5	38.5	43.5
L1	7	8	10	12	14	16
M	9	11	12	12.5	16.5	19
ϕQ	6	6	8	10	13	13
R	20	23.5	25.5	30	35	40
R1	49	56	61	69	81	92
S	4.5	5.5	5.5	6.8	6.8	9
T	8	9.5	9.5	11	11	14
U	7	12	11	11.5	13	16
X	23.5	26	30	33.5	39.5	45
Y	M3	M3	M4	M5	M6	M6
Z	P5-1B	P5-1B	P5-1B	P5-1B	P7-1B	P7-1B
AA	13	15	20	23	28	33
AC	11	12	14.5	18	21	23.5
AD	19	22	25.5	29.5	36.5	41.5
BA	7.1	7.1	6.6	7.1	7.65	7.15
BB	13.7	13.7	13.2	13.7	17.25	16.75
BC	3.9	3.9	3.4	3.9	3.8	3.3

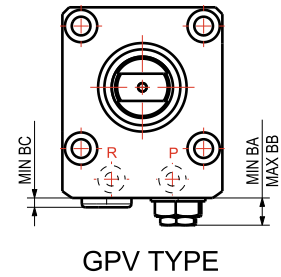

GPV TYPE

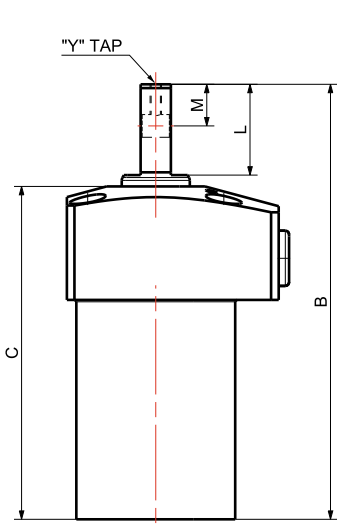
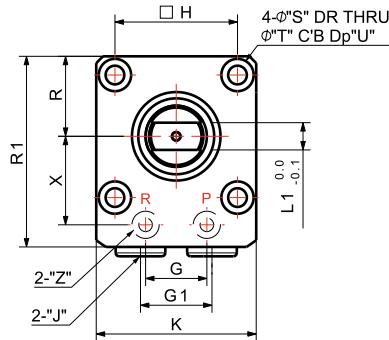

LEVER (OPTION)

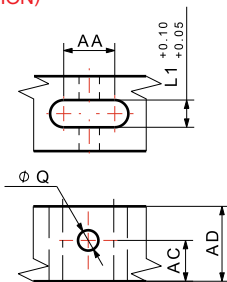
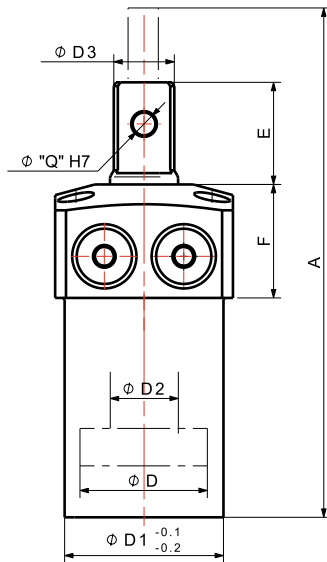



Compact Swing Clamp GQ / GQV Type (Quick Change Rod)

Features

1. 빠른 레버 교환
 2. 빠른 제품 장탈착
 3. 내경범위 : $\phi 25\sim 60$
 4. 작동압력 : $20\sim 70\text{kgf/cm}^2$
 5. 사용온도 : $0\sim 60^\circ\text{C}$
 6. 레버 조립 시 고정 상태에서 볼트 체결
 7. 레버는 옵션 사항임
1. Quick lever change
 2. Rapid installation and removal of workpiece
 3. Piston Diameter : $\phi 25\sim 60$
 4. Operating Pressure : $20\sim 70\text{kgf/cm}^2$
 5. Operating Temperature : $0\sim 60^\circ\text{C}$
 6. When assembling the lever, the bolts should be fastened in a fixed state.
 7. Lever is option item

GQV type 주문 가능합니다.
GQV type is available.

P : Clamp
R : Unclamp

> CSDR - 25 16 GQ CSDR - 25 16 GQV

① ② ③ ④ ① ② ③ ④

① R=Right, L=Left ② Piston Diameter (mm) ③ Total Stroke(mm)
④ GQ=Gasket+Quick change / GQV=Gasket+Quick change+Side Valve Type

Dimensions

MODEL NO.	CSDR/L-2516GQ	CSDR/L-3017GQ	CSDR/L-3618GQ	CSDR/L-4220GQ	CSDR/L-5026GQ	CSDR/L-6028GQ
A	120.5	132	142	144	183.5	198
B	104.5	115	124	124	157.5	170
C	80.5	88	92	88	114.5	122
ϕD	25	30	36	42	50	60
$\phi D1$	37	42	48	55	65	75
$\phi D2$	15	18	22	25	30	35
$\phi D3$	12.9	16	18.9	22	26	31
E	24	27	32	36	43	48
F	27	30	30	28	31	37
G	16	18	22	24	30	32
G1	18	21	22	24	30	32
H	31.5	36	40	47	55	63
J	G1/8	G1/8	G1/8	G1/8	G1/4	G1/4
K	40	47	51	60	70	80
L	22	25	30	34	40	46
L1	11	12.5	15	17	20	23
P	22	26	32	36	45	53
R	20	23.5	25.5	30	35	40
R1	49	56	61	69	81	92
S	4.5	5.5	5.5	6.8	6.8	9
T	8	9.5	9.5	11	11	14
U	7	12	11	11.5	13	16
X	23.5	26	30	33.5	39.5	45
Z	P5-1B	P5-1B	P5-1B	P5-1B	P7-1B	P7-1B
AA	9.5	11.6	14.5	16.5	20	23.5
AB	15	19	23	26.5	31.5	36.5
AI	15.5	19	22	26	31.5	38
AJ	6.5	8.5	11	12.5	14.5	16.5
AK	11	14	18	20	23	26
AL	2	3	4	4	5	7
AZ	M6	M8	M10	M12	M14	M16
BA	7.1	7.1	6.6	7.1	7.65	7.15
BB	13.7	13.7	13.2	13.7	17.25	16.75
BC	3.9	3.9	3.4	3.9	3.8	3.3

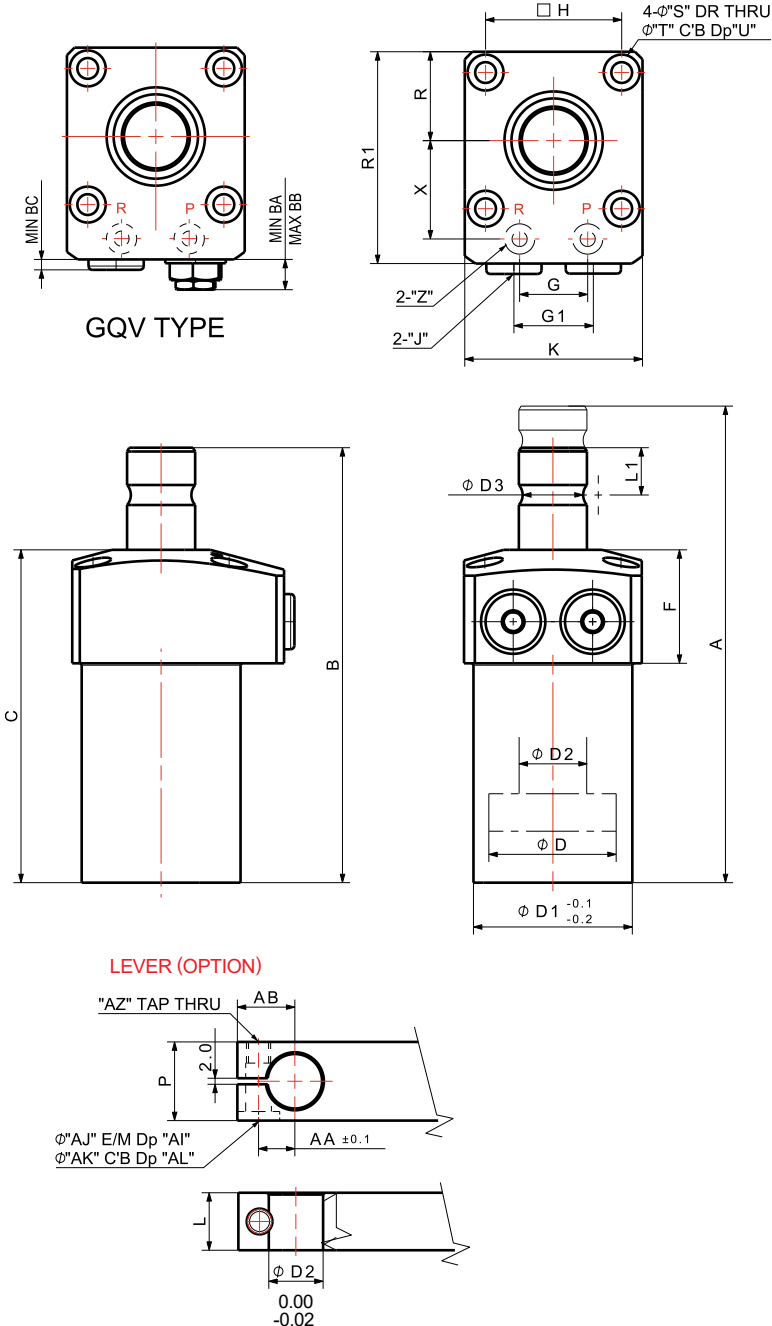

Mounting Detail

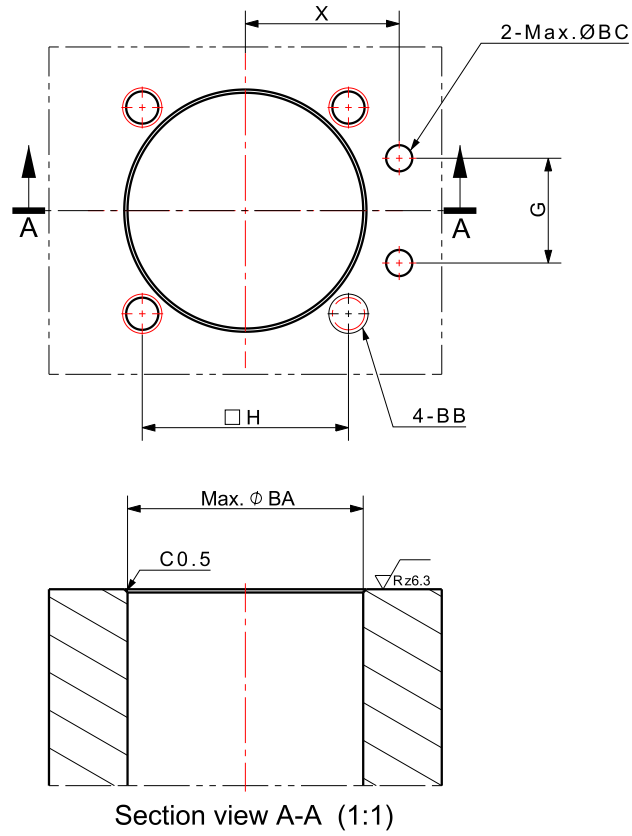

Dimensions

	MODEL NO.	G	H	X	ØBA	BB	ØBC
DIMENSIONS (mm)	CSDx-2516G	16.0	31.5	23.5	38.0	M4	4.0
	CSDx-3017G	18.0	36.0	26.0	43.0	M5	4.0
	CSDx-3618G	22.0	40.0	30.0	49.0	M5	4.0
	CSDx-4220G	24.0	47.0	33.5	56.0	M6	4.0
	CSDx-5026G	30.0	55.0	39.5	66.0	M6	6.0
	CSDx-6028G	32.0	63.0	45.0	76.0	M8	6.0

Bottom Flange Swing Clamp

Piping Method



F type 1

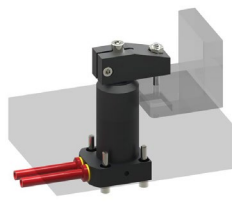

F type 2

Manifold Method

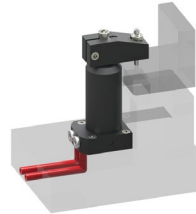

FG type

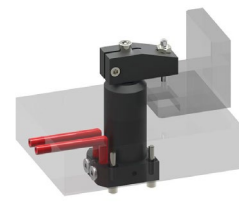

FGT type

Rod Shape



Standard



Pin Hole

Model No.

SDR-2522F



- 1** Swing Direction
For Clamping
SDR = Clockwise (시계방향)
SDL = Counter-Clockwise (반시계방향)
- 2** Piston Diameter
ex) 25 = $\phi 25$
- 3** Piston Rod Stroke
ex) 22 = 22mm
- 4** Type
 - > F = Bottom Flange
 - > FP = Bottom Flange + Pin Hole Rod
 - > FG = Bottom Flange + Gasket
 - > FGP = Bottom Flange + Gasket + Pin Hole Rod
 - * V: meter-in valve W: meter-out valve
 - > FGV = Bottom Flange + Gasket + Flow Control Valve
 - > FGPV = Bottom Flange + Gasket + Pin Hole Rod + Flow Control Valve
 - > FGT = Bottom Flange + Gasket Top
 - > FGPT = Bottom Flange + Gasket Top + Pin Hole Rod
 - > FGVT = Bottom Flange + Gasket Top + Flow Control Valve
 - > FGPVT = Bottom Flange + Gasket Top + Pin Hole Rod + Flow Control Valve
- 5** Swing Angle
No sign = 90°
ex) 30 = 30°

Specification

MODEL NO.	SDR / L-2522 □					SDR / L-3030 □					SDR / L-4045 □					SDR / L-5555 □				
Type	F	FG	FGV	FGT	FGVT	F	FG	FGV	FGT	FGVT	F	FG	FGV	FGT	FGVT	F	FG	FGV	FGT	FGVT
	FP	FGP	FGPV	FGPT	FGPVT	FP	FGP	FGPV	FGPT	FGPVT	FP	FGP	FGPV	FGPT	FGPVT	FP	FGP	FGPV	FGPT	FGPVT
Weight (kg)	1.23	1.24	1.25	1.24	1.25	2.21	2.25	2.26	2.24	2.25	3.97	4.02	4.03	4.02	4.03	8.27	8.34	8.36	8.34	8.36
	1.22	1.23	1.24	1.23	1.24	2.18	2.22	2.23	2.22	2.23	3.93	3.98	3.99	3.98	3.99	8.23	8.30	8.32	8.29	8.31
Clamping Cylinder Force (kgf) at 150kgf/cm ²	354					470					962					2,120				
Piston Diameter (mm)	$\phi 25$					$\phi 30$					$\phi 40$					$\phi 55$				
Effective Area (cm ²)	2.36					3.13					6.41					14.13				
Stroke (mm)	Swing		12			16					16					25				
	Straight		10			14					29					30				
	Total		22			30					45					55				
Oil Capacity (cm ³)	At Clamping		5.20			9.38					28.83					77.72				
Operating Pressure Range	20 - 150 kgf/cm ²																			
Operating Temperature Range	0 - 60°C																			



Bottom Flange Swing Clamp Standard Type

Features

1. 하부 플랜지
 2. 레버 교환 용이
 3. 빠른 제품 장탈착
 4. 내경범위 : $\phi 25 \sim 55$
 5. 작동압력 : $20 \sim 150 \text{ kgf/cm}^2$
 6. 사용온도 : $0 \sim 60^\circ\text{C}$
 7. 레버 조립 시 고정 상태에서 볼트 체결
 8. 레버는 옵션 사항임
1. Bottom flange
 2. Easy lever exchange
 3. Rapid installation and removal of workpiece
 4. Piston Diameter : $\phi 25 \sim 55$
 5. Operating Pressure : $20 \sim 150 \text{ kgf/cm}^2$
 6. Operating Temperature : $0 \sim 60^\circ\text{C}$
 7. When assembling the lever, the bolts should be fastened in a fixed state.
 8. Lever is option item

> SDR - 25 22 F

① ② ③ ④

- ① R=Right, L=Left ② Piston Diameter (mm) ③ Total Stroke(mm)
④ Bottom Flange Type

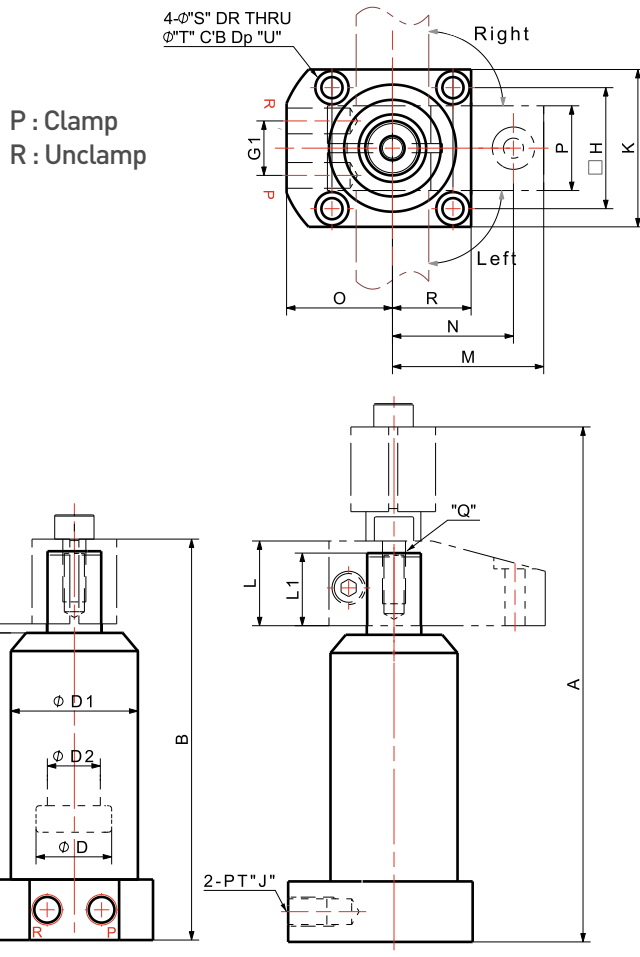

Dimensions

MODEL NO.	SDR/L- 2522F	SDR/L- 3030F	SDR/L- 4045F	SDR/L- 5555F
A	154.5	188	223	288
B	132.5	158	178	233
C	81.5	98	112	160
ϕ D	25	30	40	55
ϕ D1	42	52	65	85
ϕ D2	18	22.4	28	35
E	3	3	3	3
F	20	25	28	30
G1	18	22	24	30
H	40	46	64	76
J	PT 1/8	PT 1/4	PT 1/4	PT 3/8
K	52	60	80	97
L	28	32	35	40
L1	24	27	29	34
M	50	60	75	90
N	40	50	60	70
O	35	40	50	59
P	28	32	38	60
Q	M8 x 1.25P	M10 x 1.5P	M12 x 1.75P	M16 x 2.0P
R	26	30	40	48.5
S	7	7	9	11
T	11	11	14	17
U	7	7	9	11
V	40	46	64	76
AA	71.5	88	110	130
AB	21.5	28	35	40
AC	15	19	24.5	28
AD	12.5	14	15	17
ϕ Ad	9	11	13	17
AJ	6.5	9	11	11
AK	11	14	17	17
AL	7	9	11	20
AZ	M6	M8	M12	M16

LEVER (OPTION)

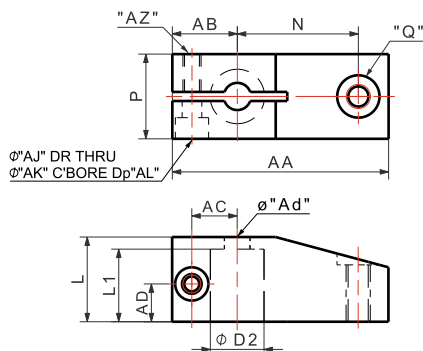



Bottom Flange Swing Clamp Gasket Type

Features

1. 가스켓 타입
 2. 레버 교환 용이
 3. 빠른 제품 장탈착
 4. 내경범위 : $\phi 25 \sim 55$
 5. 작동압력 : $20 \sim 150 \text{kgf/cm}^2$
 6. 사용온도 : $0 \sim 60^\circ\text{C}$
 7. 레버 조립 시 고정 상태에서 볼트 체결
 8. 레버는 옵션 사항임
1. Gasket type
 2. Easy lever exchange
 3. Rapid installation and removal of workpiece
 4. Piston Diameter : $\phi 25 \sim 55$
 5. Operating Pressure : $20 \sim 150 \text{kgf/cm}^2$
 6. Operating Temperature : $0 \sim 60^\circ\text{C}$
 7. When assembling the lever, the bolts should be fastened in a fixed state.
 8. Lever is option item

> SDR - 25 22 FG

SDR - 25 22 FGV

① ② ③ ④

① ② ③ ④

① R=Right, L=Left ② Piston Diameter (mm) ③ Total Stroke(mm)

④ FG = Bottom Flange Gasket / FGV = Bottom Flange Gasket + Side Valve Type

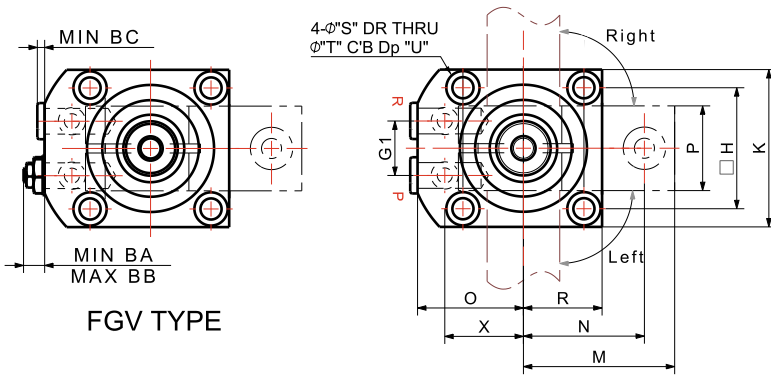

FGV TYPE

P : Clamp
R : Unclamp

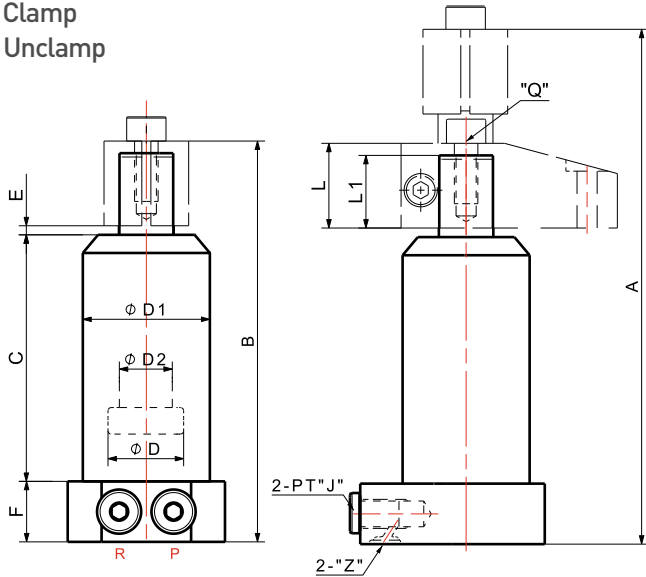

LEVER (OPTION)

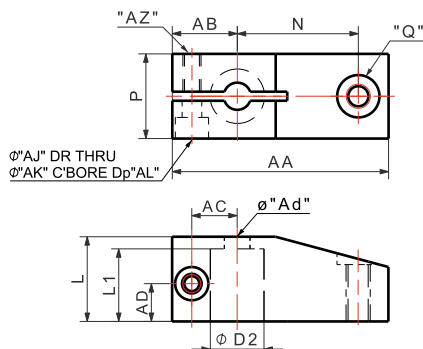

Dimensions

MODEL NO. SDR/L- 2522FG SDR/L- 3030FG SDR/L- 4045FG SDR/L- 5555FG

MODEL NO.	SDR/L- 2522FG	SDR/L- 3030FG	SDR/L- 4045FG	SDR/L- 5555FG
A	154.5	188	223	288
B	132.5	158	178	233
C	81.5	98	112	160
φD	25	30	40	55
φD1	42	52	65	85
φD2	18	22.4	28	35
E	3	3	3	3
F	20	25	28	30
G1	18	20	24	30
H	40	46	64	76
J	PT 1/8	PT 1/4	PT 1/4	PT 3/8
K	52	60	80	97
L	28	32	35	40
L1	24	27	29	34
M	50	60	75	90
N	40	50	60	70
O	35	40	50	59
P	28	32	38	60
Q	M8 x 1.25P	M10 x 1.5P	M12 x 1.75P	M16 x 2.0P
R	26	30	40	48.5
S	7	7	9	11
T	11	11	14	17
U	7	7	9	11
V	40	46	64	76
X	26	31	38	47
Z	P6	P6	P6	P7
AA	71.5	88	110	130
AB	21.5	28	35	40
AC	15	19	24.5	28
AD	12.5	14	15	17
φAd	9	11	13	17
AJ	6.5	9	11	11
AK	11	14	17	17
AL	7	9	11	20
AZ	M6	M8	M12	M16
BA	7.1	7.2	7.2	5.7
BB	13.7	16.8	16.8	15.3
BC	3.9	3.3	3.3	1.8



Bottom Flange Swing Clamp Gasket Top Type

Features

- 플랜지 상부 가스켓
- 레버 교환 용이
- 빠른 제품 장탈착
- 내경범위 : $\phi 25 \sim 55$
- 작동압력 : $20 \sim 150 \text{ kgf/cm}^2$
- 사용온도 : $0 \sim 60^\circ\text{C}$
- 레버 조립 시 고정 상태에서 볼트 체결
- 레버는 옵션 사항임
- Gasket located on the top of flange
- Easy lever exchange
- Rapid installation and removal of workpiece
- Piston Diameter : $\phi 25 \sim 55$
- Operating Pressure : $20 \sim 150 \text{ kgf/cm}^2$
- Operating Temperature : $0 \sim 60^\circ\text{C}$
- When assembling the lever, the bolts should be fastened in a fixed state.
- Lever is option item

> SDR - 25 22 FGT SDR - 25 22 FGVT

① ② ③ ④ ① ② ③ ④

① R=Right, L=Left ② Piston Diameter (mm) ③ Total stroke(mm)

④ FGT = Bottom Flange Gasket Top / FGVT = Bottom Flange Gasket Top + Side Valve Type

Dimensions

MODEL NO. SDR/L- 2522FGT SDR/L- 3030FGT SDR/L- 4045FGT SDR/L- 5555FGT

	SDR/L- 2522FGT	SDR/L- 3030FGT	SDR/L- 4045FGT	SDR/L- 5555FGT
A	154.5	188	223	288
B	132.5	158	178	233
C	81.5	98	112	160
ϕD	25	30	40	55
$\phi D1$	42	52	65	85
$\phi D2$	18	22.4	28	35
E	3	3	3	3
F	20	25	28	30
G1	18	20	24	30
H	40	46	64	76
J	PT 1/8	PT 1/4	PT 1/4	PT 3/8
K	52	60	80	97
L	28	32	35	40
L1	24	27	29	34
M	50	60	75	90
N	40	50	60	70
O	35	40	50	59
P	28	32	38	60
Q	M8 x 1.25P	M10 x 1.5P	M12 x 1.75P	M16 x 2.0P
R	26	30	40	48.5
S	7	7	9	11
T	11	11	14	17
U	7	7	9	11
V	40	46	64	76
X	26	31	38	47
Z	P6	P6	P6	P7
AA	71.5	88	110	130
AB	21.5	28	35	40
AC	15	19	24.5	28
AD	12.5	14	15	17
ϕAd	9	11	13	17
AJ	6.5	9	11	11
AK	11	14	17	17
AL	7	9	11	20
AZ	M6	M8	M12	M16
BA	7.1	7.2	7.2	5.7
BB	13.7	16.8	16.8	15.3
BC	3.9	3.3	3.3	1.8

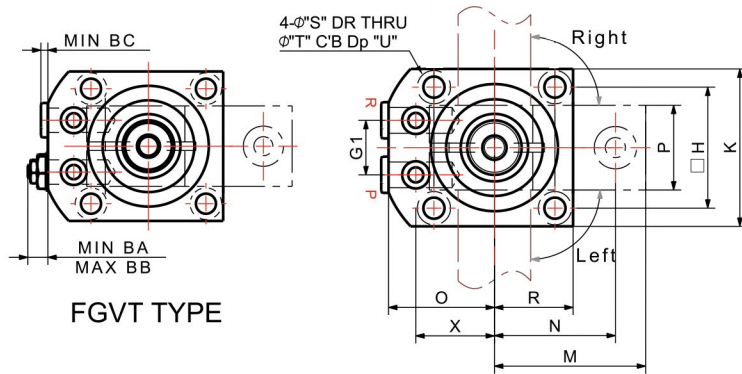

FGVT TYPE

P : Clamp
R : Unclamp

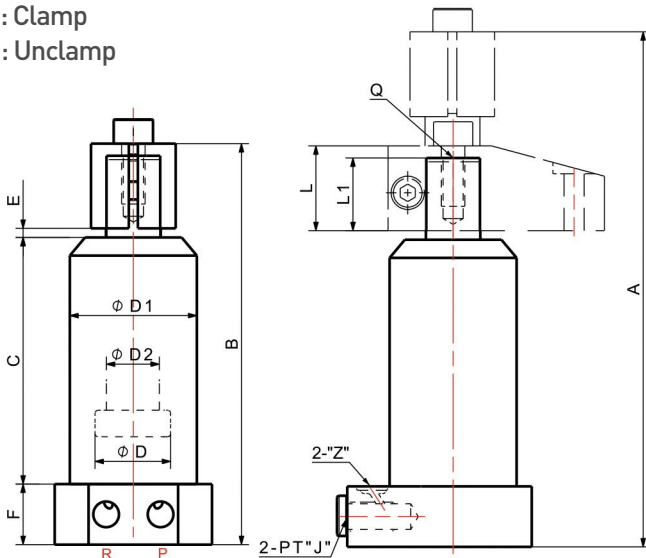

LEVER (OPTION)

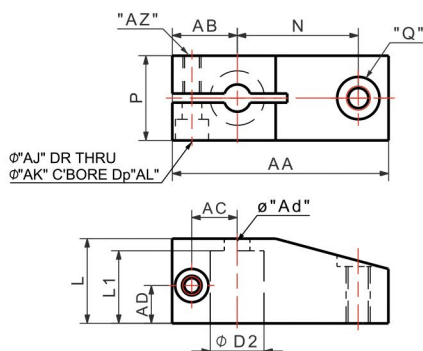

Mounting Detail

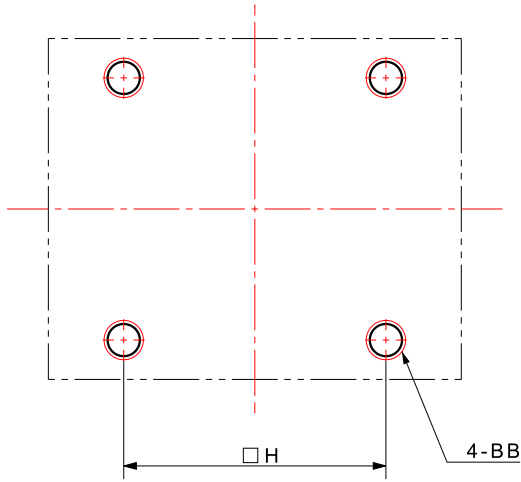

Dimensions

	MODEL NO.	H	BB
DIMENSIONS (mm)	SDx-2522F	40.0	M6
	SDx-3030F	46.0	M6
	SDx-4045F	64.0	M8
	SDx-5555F	76.0	M10

Gasket type

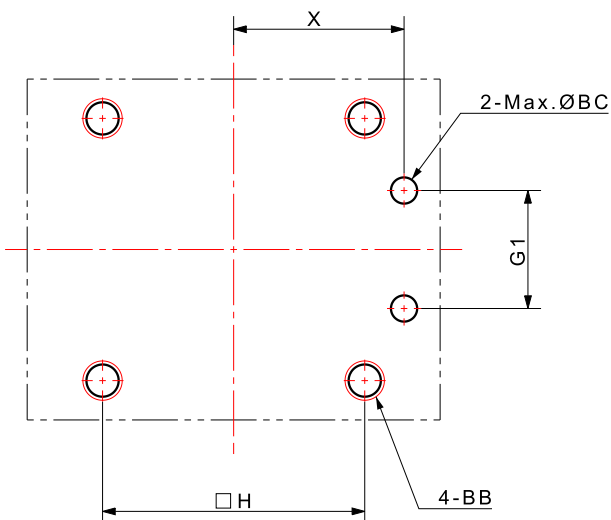

Dimensions

	MODEL NO.	G1	H	X	BB	ØBC
DIMENSIONS (mm)	SDx-2522FG	18.0	40.0	26.0	M6	5.0
	SDx-3030FG	20.0	46.0	31.0	M6	5.0
	SDx-4045FG	24.0	64.0	38.0	M8	5.0
	SDx-5555FG	30.0	76.0	47.0	M10	6.0

Gasket Top type

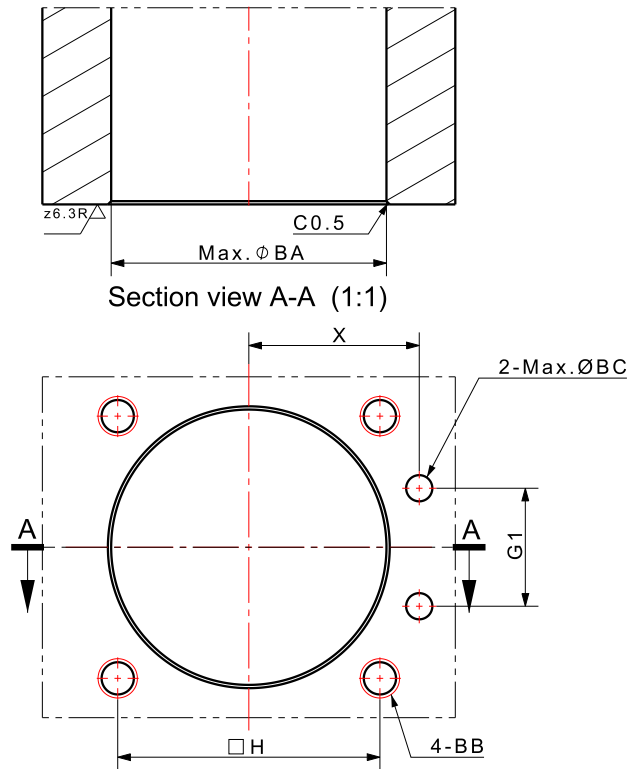

Dimensions

	MODEL NO.	G	H	X	ØBA	BB	ØBC
DIMENSIONS (mm)	SDx-2522FGT	18.0	40.0	26.0	43.0	M6	5.0
	SDx-3030FGT	20.0	46.0	31.0	53.0	M6	5.0
	SDx-4045FGT	24.0	64.0	38.0	66.0	M8	5.0
	SDx-5555FGT	30.0	76.0	47.0	86.0	M10	6.0

Top Flange Swing Clamp

Piping Method



Standard

Manifold Method

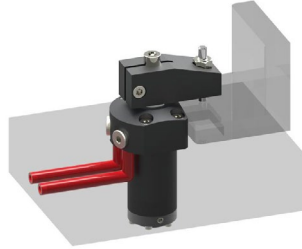

G type

Rod Shape



Standard



Pin Hole

Model No.

SDR-2522GV



1 Swing Direction
For Clamping
SDR = Clockwise (시계방향) SDL = Counter-Clockwise (반시계방향)

3 Piston Rod Stroke
ex) 22 = 22mm

5 Swing Angle
No sign = 90°
ex) 30 = 30°

2 Piston Diameter
ex) 25 = ø25

4 Type
 > No Sign = Standard
 > P = Pin Hole Rod
 > G = Gasket
 > GP = Gasket + Pin Hole Rod
 > GV = Gasket + Flow Control Valve
 > GPV = Gasket + Pin Hole Rod + Flow Control Valve
 * V: meter-in valve W: meter-out valve

Specification

MODEL NO.		SDR / L-2522 □			SDR / L-3030 □			SDR / L-4045 □			SDR / L-5555 □		
Type		No Sign	G	GV	No Sign	G	GV	No Sign	G	GV	No Sign	G	GV
		P	GP	GPV	P	GP	GPV	P	GP	GPV	P	GP	GPV
Weight (kg)		1.08	1.01	1.02	1.85	1.79	1.80	3.29	3.16	3.17	6.89	6.51	6.53
		1.06	1.00	1.01	1.83	1.77	1.78	3.25	3.12	3.13	6.85	6.48	6.50
Clamping Cylinder Force (kgf) at 150kgf/cm ²		354			470			962			2,120		
Piston Diameter (mm)		ø25			ø30			ø40			ø55		
Effective Area (cm ²)		2.36			3.13			6.41			14.13		
Stroke (mm)	Swing	12			16			16			25		
	Straight	10			14			29			30		
	Total	22			30			45			55		
Oil Capacity (cm ³)	At Clamping	5.20			9.38			28.83			77.72		
Operating Pressure Range		20 ~ 150 kgf/cm ²											
Operating Temperature Range		0 ~ 60 °C											



Top Flange Swing Clamp Standard Type

Features

- | | |
|---------------------------------------|--|
| 1. 나사산 하우징 | 1. Threaded housing |
| 2. 레버 교환 용이 | 2. Easy lever exchange |
| 3. 니플 배관 | 3. Nipple piping |
| 4. 내경범위 : $\phi 25\sim 55$ | 4. Piston Diameter : $\phi 25\sim 55$ |
| 5. 작동압력 : $20\sim 150\text{kgf/cm}^2$ | 5. Operating Pressure : $20\sim 150\text{kgf/cm}^2$ |
| 6. 사용온도 : $0\sim 60^\circ\text{C}$ | 6. Operating Temperature : $0\sim 60^\circ\text{C}$ |
| 7. 레버 조립 시 고정 상태에서 볼트 체결 | 7. When assembling the lever, the bolts should be fastened in a fixed state. |
| 8. 레버는 옵션 사항임 | 8. Lever is option item |

> SDR - 25 22

① ② ③

① R=Right, L=Left ② Piston Diameter (mm) ③ Total Stroke(mm)

Dimensions

MODEL NO.	SDR/L- 2522	SDR/L- 3030	SDR/L- 4045	SDR/L- 5555
A	152	188	223	280
B	130	158	178	225
C	99	123	140	182
ϕD	25	30	40	55
$\phi D1$	37	45.5	57	76
$\phi D2$	18	22.4	28	35
E	3	3	3	3
F	30	35	40	45
G	21	22	26	30
H	42	42	54	70
J	PT 1/8	PT 1/4	PT 1/4	PT 3/8
K	55	54	70	89
L	28	32	35	40
L1	24	27	29	34
M	50	60	75	90
N	40	50	60	70
O	32	36.5	48.5	59
P	28	32	38	60
Q	M8 x 1.25P	M10 x 1.5P	M12 x 1.75P	M16 x 2.0P
R	19	27	35	44.5
S	6.5	6.5	9	11
T	11	11	14	17
U	15	15	20	25
V	25	42	54	70
W	M40 x 1.5P	M48 x 1.5P	M60 x 1.5P	M80 x 2.0P
AA	71.5	88	110	130
AB	21.5	28	35	40
AC	15	19	24.5	28
AD	12.5	14	15	17
ϕAd	9	11	13	17
AJ	6.5	9	11	11
AK	11	14	17	17
AL	7	9	11	20
AZ	M6	M8	M12	M16

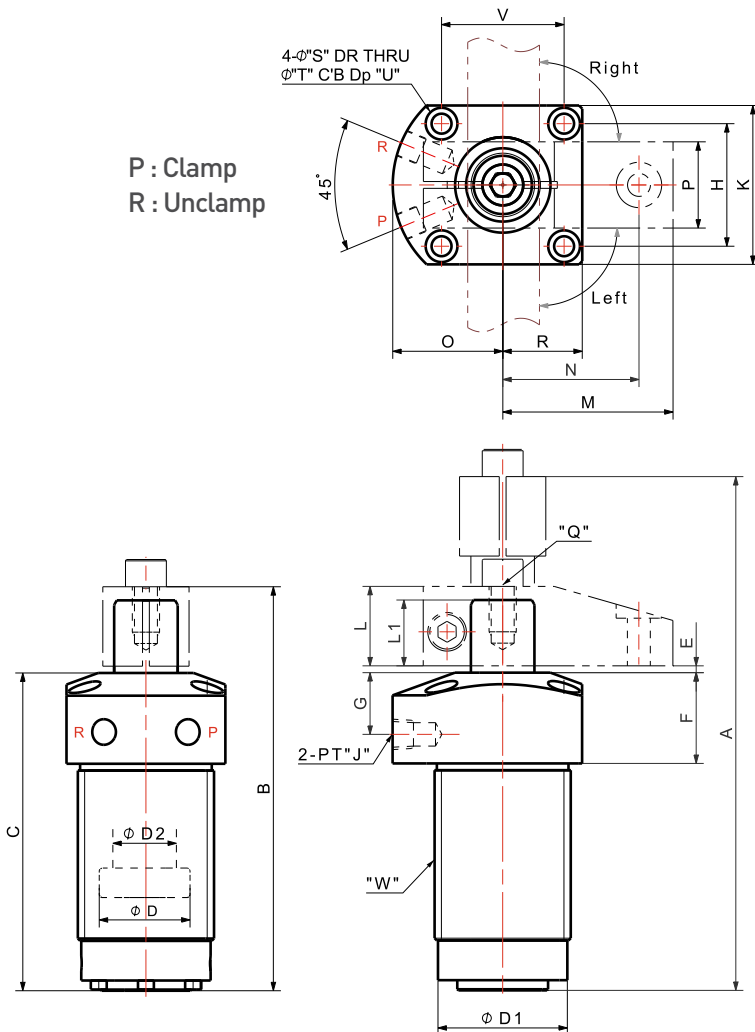

LEVER (OPTION)

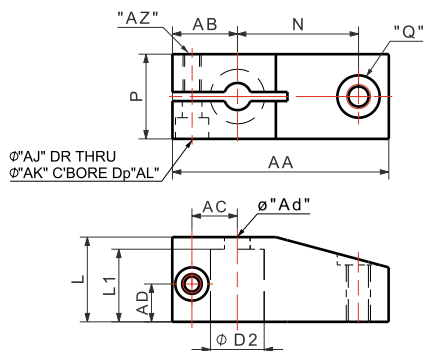



Top Flange Swing Clamp Gasket Type

Features

1. 가스켓 배관형
 2. 레버 교환 용이
 3. 내경범위 : $\phi 25 \sim 55$
 4. 작동압력 : $20 \sim 150 \text{ kgf/cm}^2$
 5. 사용온도 : $0 \sim 60^\circ\text{C}$
 6. 레버 조립 시 고정 상태에서 볼트 체결
 7. 레버는 옵션 사항임
1. Gasket manifold
 2. Easy lever exchange
 3. Piston Diameter : $\phi 25 \sim 55$
 4. Operating Pressure : $20 \sim 150 \text{ kgf/cm}^2$
 5. Operating Temperature : $0 \sim 60^\circ\text{C}$
 6. When assembling the lever, the bolts should be fastened in a fixed state.
 7. Lever is option item

> SDR - 25 22 G

SDR - 25 22 GV

① ② ③ ④

① ② ③ ④

① R=Right, L=Left ② Piston Diameter (mm) ③ Total Stroke(mm)

④ G = Gasket / GV = Gasket + Valve Type

Dimensions

MODEL NO.	SDR/L- 2522G	SDR/L- 3030G	SDR/L- 4045G	SDR/L- 5555G
A	152	188	223	280
B	130	158	178	225
C	99	123	140	182
ϕD	25	30	40	55
$\phi D1$	37	45.5	57	76
$\phi D2$	18	22.4	28	35
E	3	3	3	3
F	30	35	40	45
G1	20	23	31	35
H	42	42	54	70
J	PT 1/8	PT 1/4	PT 1/4	PT 3/8
K	55	54	70	89
L	28	32	35	40
L1	24	27	29	34
M	50	60	75	90
N	40	50	60	70
O	32	36.5	48.5	59
P	28	32	38	60
Q	M8 x 1.25P	M10 x 1.5P	M12 x 1.75P	M16 x 2.0P
R	19	27	35	44.5
S	6.5	6.5	9	11
T	11	11	14	17
U	15	15	20	25
V	25	42	54	70
X	23	25.5	35	43
Z	P6	P6	P6	P10
AA	71.5	88	110	130
AB	21.5	28	35	40
AC	15	19	24.5	28
AD	12.5	14	15	17
ϕAd	9	11	13	17
AJ	6.5	9	11	11
AK	11	14	17	17
AL	7	9	11	20
AZ	M6	M8	M12	M16
BA	7.2	7.2	7.2	5.7
BB	13.7	16.8	16.8	15.3
BC	3.9	3.3	3.3	1.8

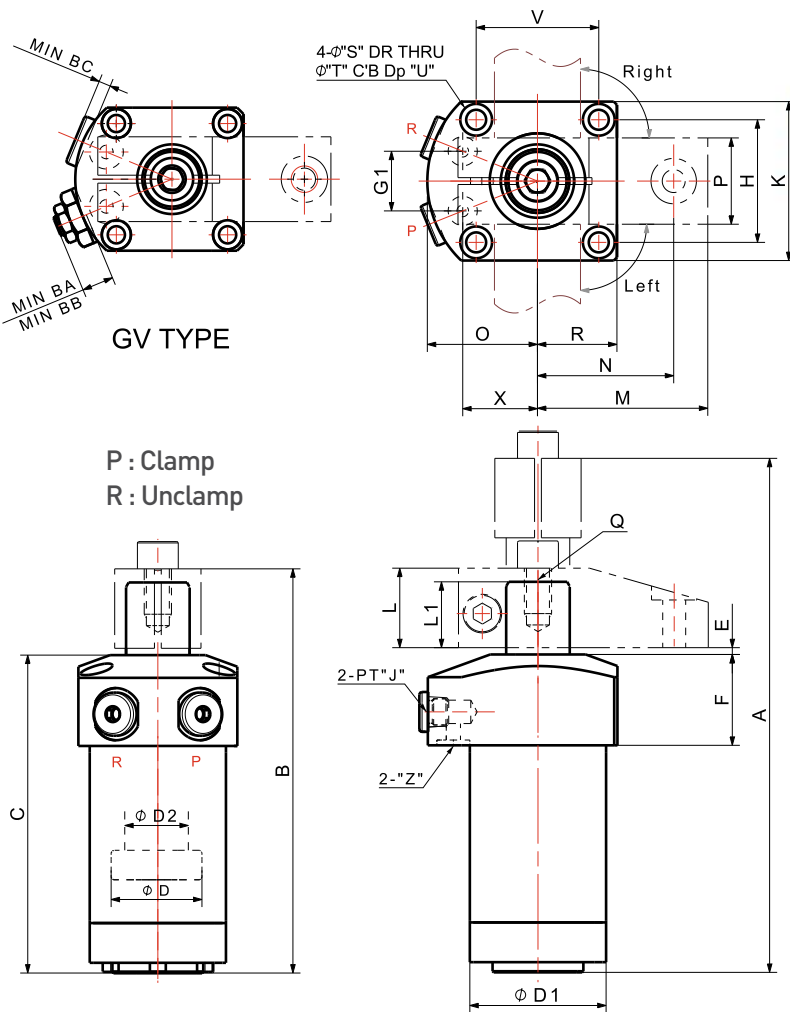

LEVER (OPTION)

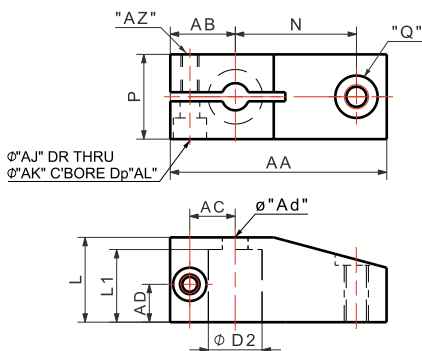

Pin Hole Rod

P/GP/GPV Type

FP/FGP/FGPV/FGPT/FGPVT Type



Top Flange



Bottom Flange

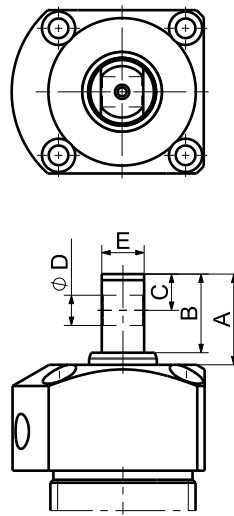

Top Flange Type

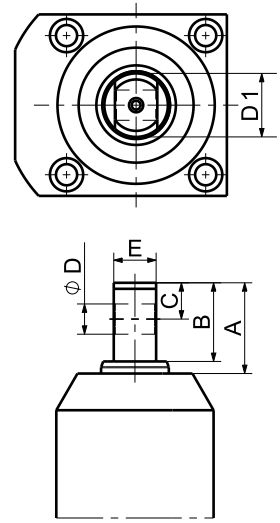

Bottom Flange Type

MODEL NO.	DIMENSIONS (mm)					
	A	B	C	ϕD	$\phi D1$	E
SDR/L-2522□P□	27	22.5	10	8	17	12
SDR/L-3030□P□	30	26	12	10	21	14
SDR/L-4045□P□	34	31	14	12	26.5	18
SDR/L-5555□P□	43	38	18	16	33	22

Lever (Option)

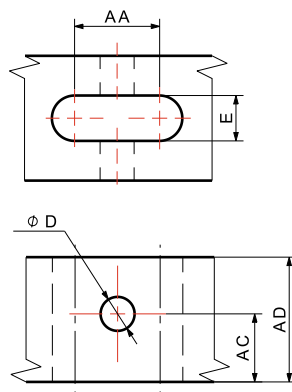

MODEL NO.	DIMENSIONS (mm)				
	AA	AC	ϕD	AD	E
SDR/L-2522□P□	17	11.5	8	20.5	12
SDR/L-3030□P□	21	13	10	24	14
SDR/L-4045□P□	26	16	12	29	18
SDR/L-5555□P□	33	19	16	36	22

클램프 능력 Clamp Capability

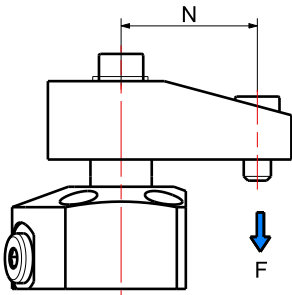

Standard Lever

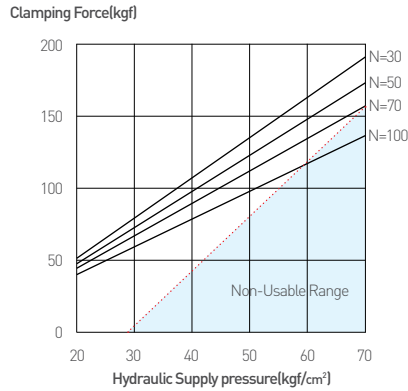

CSDR/L-2516□

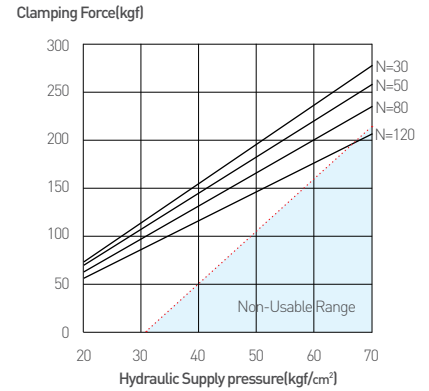

CSDR/L-3017□

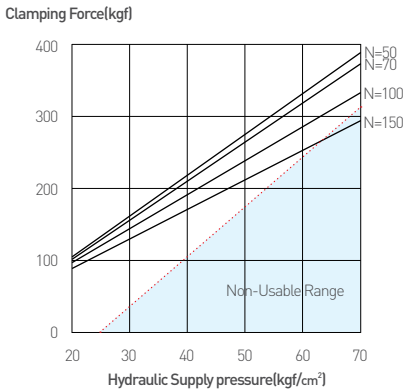

CSDR/L-3618□

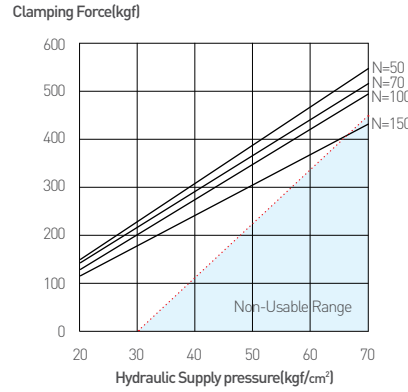

CSDR/L-4220□

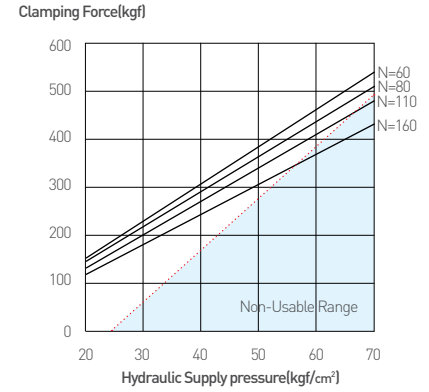

CSDR/L-5026□

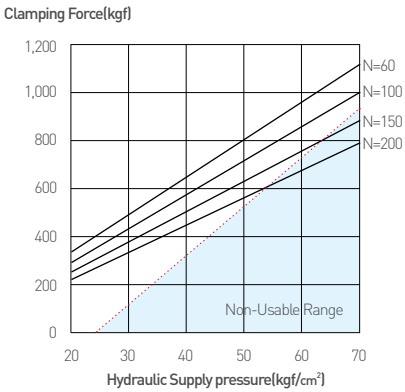

CSDR/L-6028□

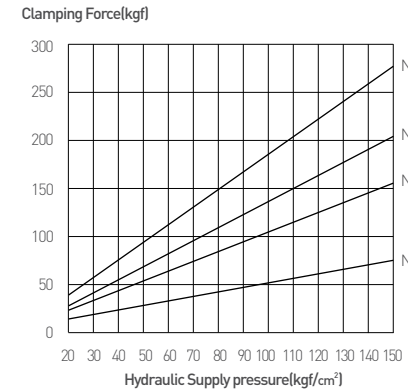

SDR/L-2522□

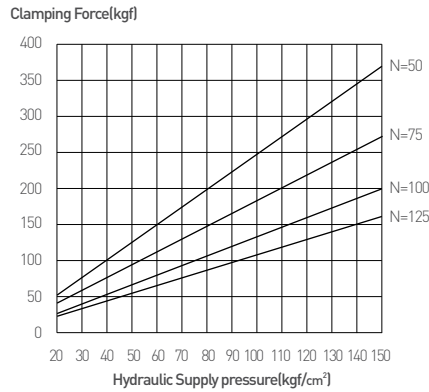

SDR/L-3030□

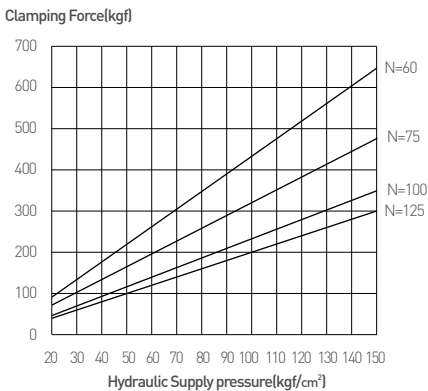

SDR/L-4045□

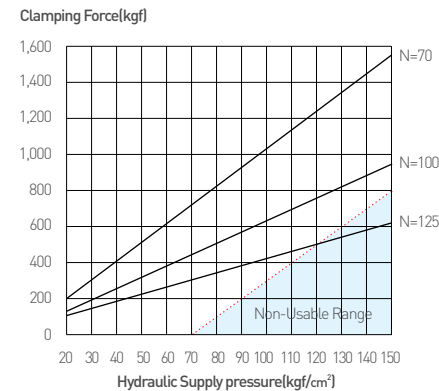

SDR/L-5555□

Balance Lever

Clamping Force Formula

CSDR/L-2516GP□

$$F1 = \frac{N1}{N} \times 3.14 \times P$$

$$F2 = \frac{N2}{N} \times 3.14 \times P$$

CSDR/L-3017GP□

$$F1 = \frac{N1}{N} \times 4.52 \times P$$

$$F2 = \frac{N2}{N} \times 4.52 \times P$$

CSDR/L-3618GP□

$$F1 = \frac{N1}{N} \times 6.37 \times P$$

$$F2 = \frac{N2}{N} \times 6.37 \times P$$

CSDR/L-4220GP□

$$F1 = \frac{N1}{N} \times 8.94 \times P$$

$$F2 = \frac{N2}{N} \times 8.94 \times P$$

CSDR/L-5026GP□

$$F1 = \frac{N1}{N} \times 12.56 \times P$$

$$F2 = \frac{N2}{N} \times 12.56 \times P$$

CSDR/L-6028GP□

$$F1 = \frac{N1}{N} \times 18.64 \times P$$

$$F2 = \frac{N2}{N} \times 18.64 \times P$$

권고사항 Recommendations

1. 보조 가이드 핀 설치

포인트를 클램핑 하려면 보조 가이드 핀을 설치하십시오.

1. Assist Guide Pin Installation

If you want to clamp at specific point, please install the assist guide pin.

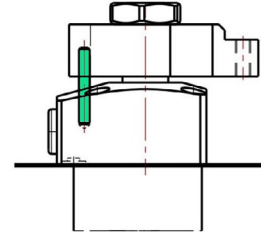
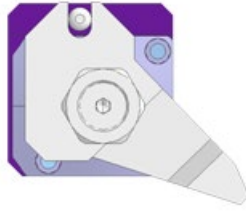

측면 부하 방지 효과도 있음.

It also has an effect of preventing lateral load.

2. 레버 길이

레버의 길이가 길거나 무거우면, 속도조절밸브와 보조가이드 핀 설치가 꼭 필요합니다.

2. Lever Length

If lever is long or heavy, speed control valve and assist guide pin must be installed.

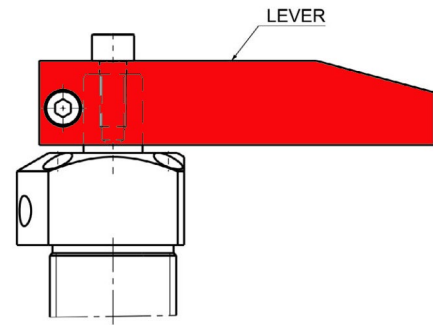

3. 작동속도 조절

스윙클램프는 작동속도가 빠르면 관성 모멘트로 인하여 클램프 손상요인이 됨으로 작동속도를 적절하게 조절 하십시오. 클램핑 속도 뿐만 아니라 언클램핑 속도도 조절하십시오.

3. Operating Speed Control

Please control both clamping and unclamping speed of swing clamp properly to prevent damage due to moment of inertia by fast operation.

4. 스피드 컨트롤 밸브 사용을 권장합니다.

4. Using Speed Control Valve is recommended.

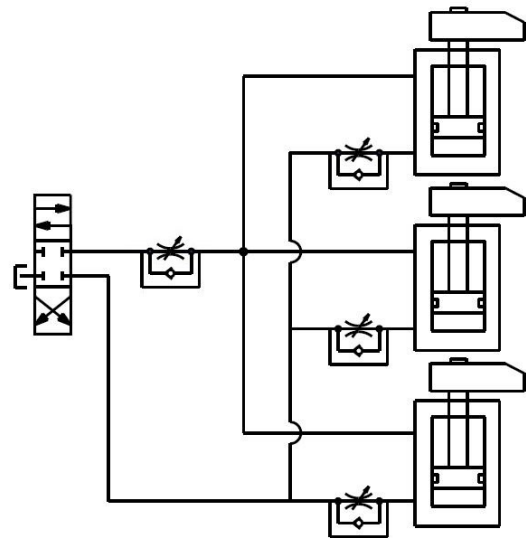

Block Clamp Introduction

블럭 클램프는 일반 유압실린더와 비교하면 80mm가 짧습니다. 심플하고 컴팩트한 디자인은 좁은 공간에 설치하기 쉽습니다. 케이제이에프는 다양한 사이즈의 블럭 클램프를 구비하고 있습니다.

Block clamp is shorter than a normal hydraulic cylinder by 80 mm. It is simple and compact, and easy to install in a crawlspace. KJF provides various sizes of block clamps.



Mounting Method

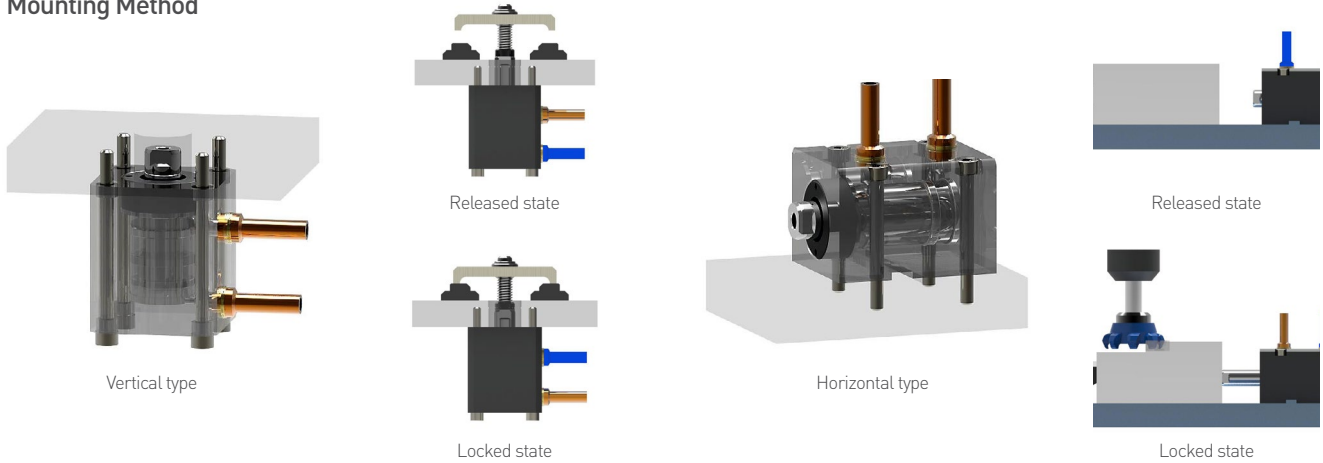

규격품 외 변형제품 Change of design

- 카다로그 외 SIZE Size besides catalogue
- Stroke 5mm, 35mm, 75mm, 100mm, 125mm 등
- Stroke 5mm, 35mm, 75mm, 100mm, 125mm etc.

- 회전 방지 및 밸브 장착 가능.
- Rotation prevention and installing valve are possible.
- 주의: 렌치로 로드헤드를 고정 후 부품을 조립 하십시오.
- Caution: Assemble the parts after fixing the load head with a wrench.

Port의 위치를 변경하고자 할 때 Changing Port location

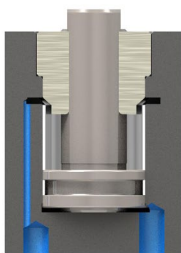

Gasket Type을 원할 경우 Case of Gasket type

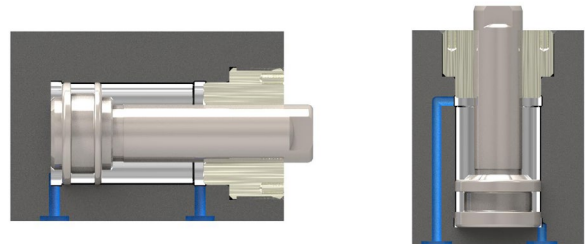

Piston Rod를 변경하고자 할 때 Changing Piston rod



Block Clamp Applications



Block Clamp Line Up

	<p>Vertical Push/Pull type Model No. BDV-□</p>	<p>니플 배관방식 Nipple Piping Method</p>	
	<p>Vertical Push/Pull Gasket type Model No. BDV-□G</p>	<p>매니폴더 배관방식 Manifold Piping Method</p>	
	<p>Vertical Push/Pull Double Rod Type Model No. BDV-□D</p>	<p>니플 배관방식 Nipple Piping Method</p>	
	<p>Vertical Push Type Model No. BPV-□</p>	<p>니플 배관방식 Nipple Piping Method</p>	
	<p>Horizontal Push/Pull Type Model No. BDH-□</p>	<p>니플 배관방식 Nipple Piping Method</p>	
	<p>Horizontal Push/Pull Gasket Type Model No. BDH-□G</p>	<p>매니폴더 배관방식 Manifold Piping Method</p>	
	<p>Horizontal Push/Pull Double Rod Type Model No. BDH-□D</p>	<p>니플 배관방식 Nipple Piping Method</p>	
	<p>Horizontal Push Type Model No. BPH-□</p>	<p>니플 배관방식 Nipple Piping Method</p>	

Model No. Explanation

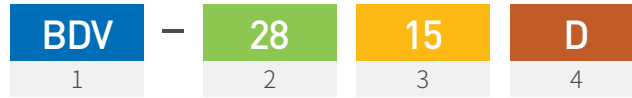

1 Clamp Type

- BDV:** Block Clamp/Double-Acting(Push & Pull)/Vertical Type
- BPV:** Block Clamp/Single-Acting(Push)/Vertical Type
- BDH:** Block Clamp/Double-Acting(Push & Pull)/Horizontal Type
- BPH:** Block Clamp/Single-Acting(Push)/Horizontal Type

2 Cylinder Inner Diameter(∅)

<p>BDV/BDH</p> <p>20 = 20mm</p> <p>25 = 25mm</p> <p>28 = 28mm</p> <p>32 = 32mm</p> <p>40 = 40mm</p> <p>50 = 50mm</p> <p>63 = 63mm</p> <p>80 = 80mm</p> <p>100 = 100mm</p> <p>125 = 125mm</p>	<p>BDV/BDH-□D</p> <p>28 = 28mm</p> <p>32 = 32mm</p> <p>40 = 40mm</p> <p>50 = 50mm</p> <p>63 = 63mm</p> <p>80 = 80mm</p>	<p>BPV/BPH</p> <p>28 = 28mm</p> <p>32 = 32mm</p> <p>40 = 40mm</p> <p>50 = 50mm</p> <p>63 = 63mm</p>
--	---	---

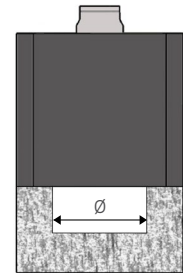

3 Piston Rod Stroke

<p>BDV/BDH</p> <p>10 = 10mm</p> <p>15 = 15mm</p> <p>20 = 20mm</p> <p>25 = 25mm</p> <p>30 = 30mm</p> <p>50 = 50mm</p> <p>75 = 75mm</p> <p>100 = 100mm</p>	<p>BDV/BDH-□D</p> <p>15 = 15mm</p> <p>25 = 25mm</p> <p>50 = 50mm</p>	<p>BPV/BPH</p> <p>15 = 15mm</p> <p>25 = 25mm</p>
--	--	--

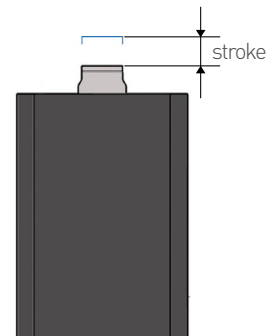

4 Piping Method & Function Type

No sign: Nipple Piping

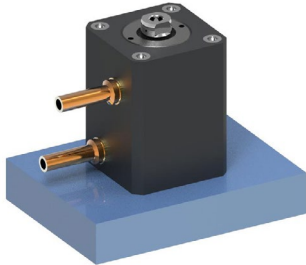

G : Manifold Piping

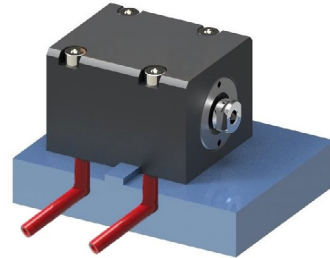

GU : Upper Manifold Piping

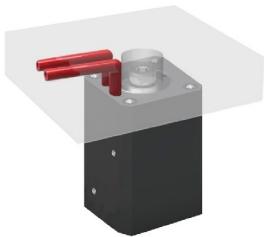

D : Double Rod

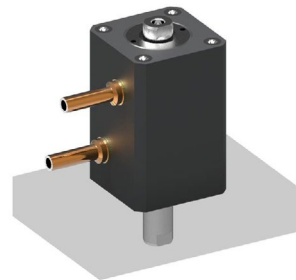

C : Threaded Rod



P : Pin Hole Rod



Vertical Block Clamp

Piping Method

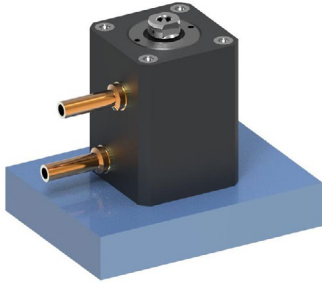

Push / Pull Type

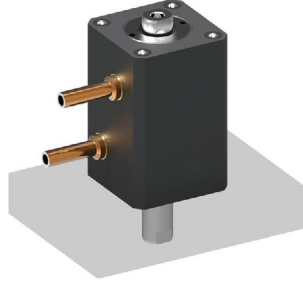

Double Rod Type



Push Type

Manifold Method

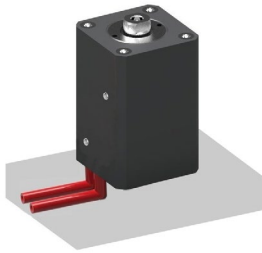

Gasket Type

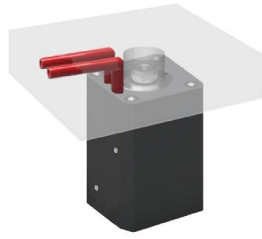

Gasket Upper Type

Rod Shape (재고문의 바랍니다)



Threaded



Pin Hole

Model No.

BDV-2815D

BDV	-	28	15	D
1		2	3	4

1 Clamp Type

BDV = Block Clamp, Double(Push/Pull)-acting, Vertical type
BPV = Block Clamp, Single(Push)-acting, Vertical type

2 Piston Diameter

ex) 28 = $\varnothing 28$

3 Piston Rod Stroke

ex) 15 = 15mm

4 Type

- > No Sign = Standard
- > C = Threaded Rod
- > P = Pin Hole Rod
- > D = Double Rod
- > DC = Threaded Double Rod
- > G = Gasket
- > GU = Gasket Upper
- > GC = Gasket + Threaded Rod
- > GCU = Gasket Upper + Threaded Rod
- > GP = Gasket + Pin Hole Rod
- > GPU = Gasket Upper + Pin Hole Rod

Specification

Push/Pull Type

* C/P, G/GU, GC/GCU, GP/GPU type도 아래표에 적용됩니다.
 * C/P, G/GU, GC/GCU and GP/GPU types are applied to below specification.

MODEL NO.	Weight (kg)	Max. Clamping Force(kgf)		Effective Area (cm ²)		Oil Capacity (cm ³)		Operating Pressure Range	Operating Temperature Range
		Push	Pull	Push	Pull	Push	Pull		
BDV-2010	0.69	790	500	3.1	2.0	3.1	2.0	15~250 kgf/cm ²	0~60°C
BDV-2015	0.76					4.7	3.0		
BDV-2020	0.82					6.3	4.0		
BDV-2025	0.88					7.9	5.0		
BDV-2030	0.95	9.4	6.0						
BDV-2510	0.94	1,230	840	4.9	3.4	4.9	3.4		
BDV-2515	1.02					7.4	5.1		
BDV-2520	1.09					9.8	6.7		
BDV-2525	1.18					12.3	8.4		
BDV-2530	1.26	14.7	10.1						
BDV-2815	1.5	1,520	1,020	6.1	4.1	9.3	6.2		
BDV-2825	1.7					15.4	10.4		
BDV-2850	2.3					30.8	20.7		
BDV-3215	1.8					12.0	8.2		
BDV-3225	2.1	2,000	1,370	8.0	5.5	20.1	13.7		
BDV-3250	2.8					40.2	27.5		
BDV-4015	2.3	3,120	2,150	12.5	8.6	18.9	12.9		
BDV-4025	2.5					31.4	21.6		
BDV-4050	3.3					62.8	43.1		

MODEL NO.	Weight (kg)	Max. Clamping Force(kgf)		Effective Area (cm ²)		Oil Capacity (cm ³)		Operating Pressure Range	Operating Temperature Range
		Push	Pull	Push	Pull	Push	Pull		
BDV-5015	3.3	4,950	3,400	19.6	13.4	29.4	20.2	15~250 kgf/cm ²	0~60°C
BDV-5025	3.6					49.1	33.7		
BDV-5050	4.5					98.2	67.4		
BDV-6315	4.7					46.8	31.8		
BDV-6325	5.2	7,770	5,320	31.1	21.3	78.0	53.2		
BDV-6350	6.3					155.9	106.4		
BDV-8015	10.5	12,550	8,600	50.2	34.4	75.4	51.5		
BDV-8025	11.5					125.7	85.9		
BDV-8050	14.3					251.4	171.8		
BDV-10050	15.5					392.5	269.5		
BDV-10075	17.8	19,630	13,470	78.5	53.9	588.8	404.3		
BDV-100100	20.1					785.0	539.0		
BDV-12550	25.2	30,670	22,380	122.7	89.5	613.5	447.5		
BDV-12575	28.3					920.3	671.3		
BDV-125100	31.5					1,277.0	895.0		

Push/Pull Double Rod Type

* DC type도 아래표에 적용됩니다.
 * DC type is applied to below specification.

MODEL NO.	Max. Clamping Force(kgf)		Effective Area (cm ²)		Oil Capacity (cm ³)		Weight (kg)	Operating Pressure Range	Operating Temperature Range
	Push	Pull	Push	Pull	Push	Pull			
BDV-2815D	1,020		4.1		6.2	1.7	15~250 kgf/cm ²	0~60°C	
BDV-2825D					10.4	1.9			
BDV-2850D					20.7	2.7			
BDV-3215D	1,370		5.5		8.2	2.0			
BDV-3225D					13.7	2.5			
BDV-3250D					27.5	3.2			
BDV-4015D	2,150		8.6		12.9	2.7			
BDV-4025D					21.6	2.9			
BDV-4050D					43.1	3.9			
BDV-5015D	3,400		13.6		20.2	3.9			
BDV-5025D					33.7	4.2			
BDV-5050D					67.4	5.3			
BDV-6315D	5,320		21.3		31.8	5.7			
BDV-6325D					53.2	6.2			
BDV-6350D					106.4	7.6			
BDV-8015D	8,600		34.4		51.5	12.5			
BDV-8025D					85.9	12.6			
BDV-8050D					171.8	15.7			

Push Type

MODEL NO.	Max. Clamping Force(kgf)	Effective Area (cm ²)	Oil Capacity (cm ³)	Weight (kg)	Operating Pressure Range	Operating Temperature Range
	Push	Push	Push			
BPV-2815	1,520	6.1	9.3	1.4	15~250 kgf/cm ²	0~60°C
BPV-2825			15.4	1.9		
BPV-3215	2,000	8.0	12.0	1.9		
BPV-3225			20.1	2.4		
BPV-4015	3,120	12.5	18.9	2.4		
BPV-4025			31.4	2.9		
BPV-5015	4,950	19.8	29.5	3.3		
BPV-5025			49.1	4.1		
BPV-6315	7,770	31.1	46.8	4.9		
BPV-6325			78.0	5.4		



Vertical Block Clamp Push/Pull Type

Features

- | | |
|-------------------------------------|---|
| 1. 복동으로 작동 | 1. Double-acting |
| 2. 다양한 사이즈 | 2. Various sizes |
| 3. 설치 용이 | 3. Easy installation |
| 4. 작동압력 : 15~250kgf/cm ² | 4. Operating Pressure : 15~250kgf/cm ² |
| 5. 피스톤 속도 : 8~100mm/s | 5. Piston Speed : 8~100mm/s |
| 6. 사용온도 : 0~60°C | 6. Operating Temperature : 0~60°C |

- > **BDV - 20 10** **BDV - 20 10 C** **BDV - 20 10 P**
 ① ② ③ ① ② ③ ④ ① ② ③ ④

- ① Vertical Type ② Piston Diameter(mm) ③ Stroke(mm)
 ④ Threaded Rod, Pin Hole Rod

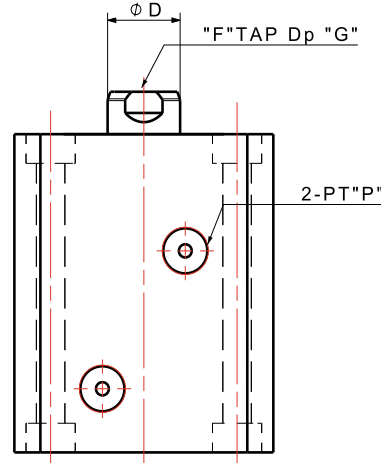
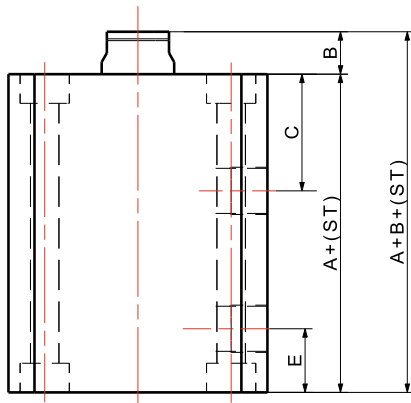
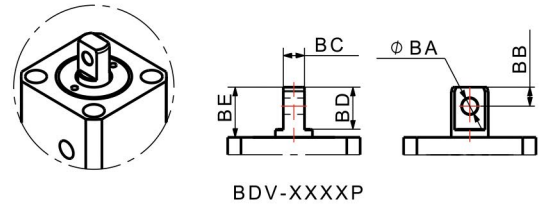
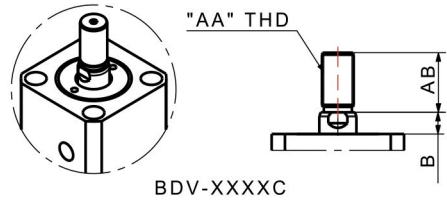
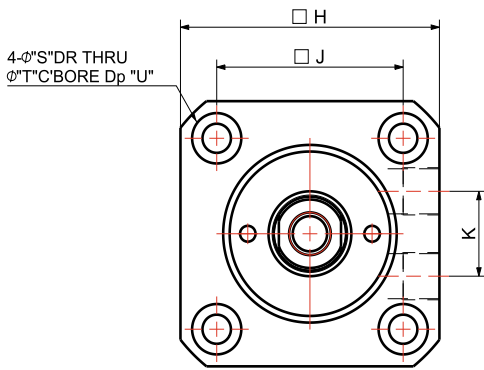

* BDV-20□□ 제품들은 경우에 따라 K치수가 0인 제품이 출고될 수 있음. 배관 시 문제가 된다면 발주 전에 확인바랍니다.

BDV-20□□ products may sometimes be shipped with a "K" dimension of 0. If this could cause issues with piping, please check before placing an order.

Dimensions

MODEL NO.	DIMENSIONS (mm)																				Piston dia.	
	A	B	C	øD	E	F	G	H	J	K	P	S	T	U	AA	AB	BA	BB	BC	BD		BE
BDV-20xx	43	8	21	12	12	M8 x 1.25P	16	44	30	12	1/8	5.5	9.5	7	M10 x 1.25P	20	ø6	7	8	15.5	18.5	ø20
BDV-25xx	45	8	22	14	12	M8 x 1.25P	16	50	36	16	1/8	5.5	9.5	5.5	M12 x 1.25P	22	ø6	7	8	15.5	18.5	ø25
BDV-28xx	50	8	23	16	12	M8 x 1.25P	12	56	42	16	1/8	5.5	9.5	5.5	M14 x 1.5P	25	ø8	8	12	20.5	23.5	ø28
BDV-32xx	54	10	26	18	12	M10 x 1.5P	15	62	47	20	1/4	6.6	11	7	M16 x 1.5P	25	ø8	9	14	21.5	24.5	ø32
BDV-40xx	55	10	27	22.4	12	M12 x 1.75P	20	70	52	20	1/4	9	14	9	M20 x 1.5P	30	ø10	11	16	25.5	28.5	ø40
BDV-50xx	60	10	29	28	13	M16 x 2.0P	25	80	58	20	1/4	11	17.5	11	M24 x 1.5P	35	ø12	13	20	29.5	32.5	ø50
BDV-63xx	67	13	31.5	35.5	15	M20 x 2.5P	33	94	69	20	1/4	14	20	13	M30 x 1.5P	45	ø16	17	25	35.5	38.5	ø63
BDV-80xx	78	17	33	45	20	M24 x 3.0P	33	114	86	30	3/8	16	23	16	M39 x 1.5P	60	ø18	20	32	42.5	45.5	ø80
BDV-100xx	88	20	41.5	56	22.5	M36 x 4.0P	40	136	102	46	3/8	20	29	20								ø100
BDV-125xx	102	25	43	65	25	M42 x 4.5P	45	163	124	52	1/2	21	31	22								ø125



G Type



GU Type

* Threaded Rod와 Pin Hole Rod Type 가능합니다.
* Threaded Rod and Pin Hole Rod Type are available.

Vertical Block Clamp Push/Pull Gasket Type

Features

- | | |
|-------------------------------------|---|
| 1. 복동으로 작동 | 1. Double-acting |
| 2. 가스켓 타입 포트 | 2. Gasket type ports |
| 3. 설치 용이 | 3. Easy installation |
| 4. 작동압력 : 15~250kgf/cm ² | 4. Operating Pressure : 15~250kgf/cm ² |
| 5. 피스톤 속도 : 8~100mm/s | 5. Piston Speed : 8~100mm/s |
| 6. 사용온도 : 0~60°C | 6. Operating Temperature : 0~60°C |

> BDV-20 10 G BDV-20 10 GU BDV-20 10 GC BDV-20 10 GP
 ① ② ③ ④ ① ② ③ ④ ① ② ③ ④ ① ② ③ ④

BDV-20 10 GCU BDV-20 10 GPU
 ① ② ③ ④ ① ② ③ ④

① Vertical Type ② Piston Diameter(mm) ③ Stroke(mm)
 ④ Gasket, Gasket Upper, Gasket + Threaded Rod, Gasket Upper + Pin Hole Rod

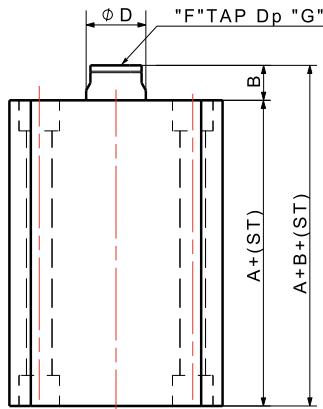
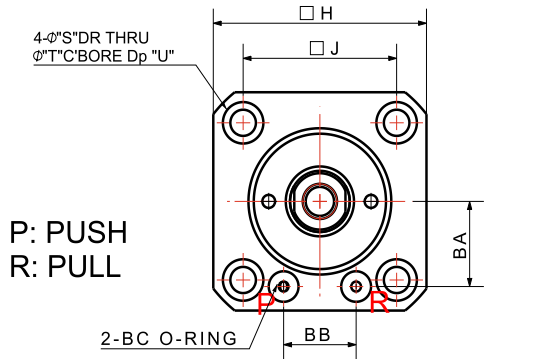
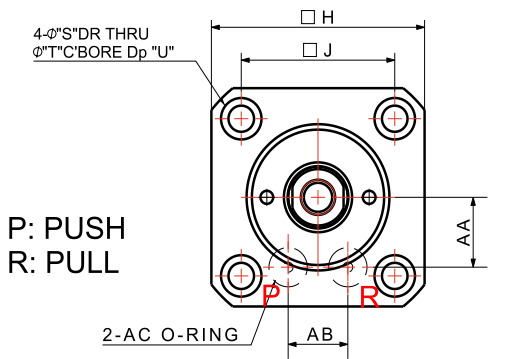

G TYPE

유량조절밸브 장착타입은
주문제작으로 가능함.
Flow Control Valve Type is
available as customized.

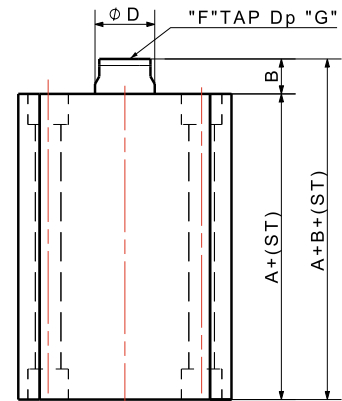
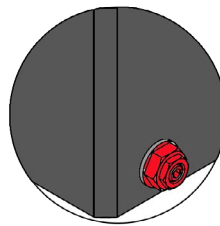

GU TYPE

Dimensions

MODEL NO.	DIMENSIONS [mm]																	
	A	B	øD	F	G	H	J	S	T	U	AA	AB	AC	BA	BB	BC	Piston dia.	
BDV-20xxGx	43	8	12	M8 x 1.25P	16	44	30	5.5	9.5	7	13	10	P5	16.5	11	P4	ø20	
BDV-25xxGx	45	8	14	M8 x 1.25P	16	50	36	5.5	9.5	5.5	16	14	P6	19.5	17	P4	ø25	
BDV-28xxGx	50	8	16	M8 x 1.25P	12	56	42	5.5	9.5	5.5	17	16	P7	21	20	P5	ø28	
BDV-32xxGx	54	10	18	M10 x 1.5P	15	62	47	6.6	11	7	20	20	P8	24	24	P6	ø32	
BDV-40xxGx	55	10	22.4	M12 x 1.75P	20	70	52	9	14	9	24	20	P9	27.5	25	P6	ø40	
BDV-50xxGx	60	10	28	M16 x 2.0P	25	80	58	11	17.5	11	28	20	P9	31.5	27	P6	ø50	



Vertical Block Clamp Push/Pull Double Rod Type

Features

- | | |
|-------------------------------------|---|
| 1. 양로드형 | 1. Double rod type |
| 2. 다양한 사이즈 | 2. Various sizes |
| 3. 복동으로 작동 | 3. Double-acting |
| 4. 작동압력 : 15~250kgf/cm ² | 4. Operating Pressure : 15~250kgf/cm ² |
| 5. 피스톤 속도 : 8~100mm/s | 5. Piston Speed : 8~100mm/s |
| 6. 사용온도 : 0~60°C | 6. Operating Temperature : 0~60°C |

> **BDV - 28 15 D** **BDV - 28 15 DC**

① ② ③ ④ ① ② ③ ④

- ① Vertical Type ② Piston Diameter(mm) ③ Stroke(mm)
④ Double Rod Type, Double + Threaded Rod

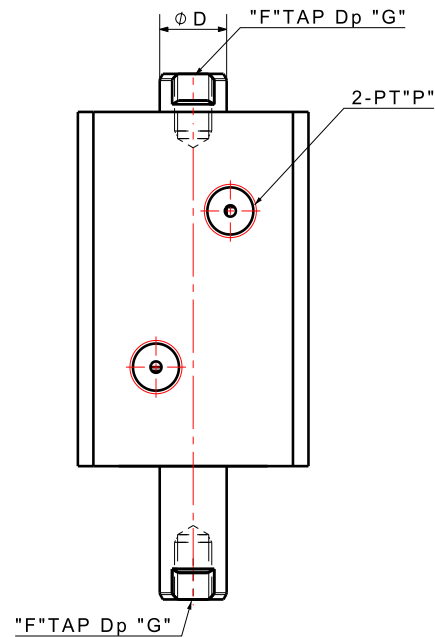
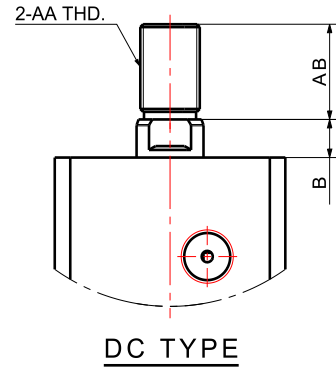
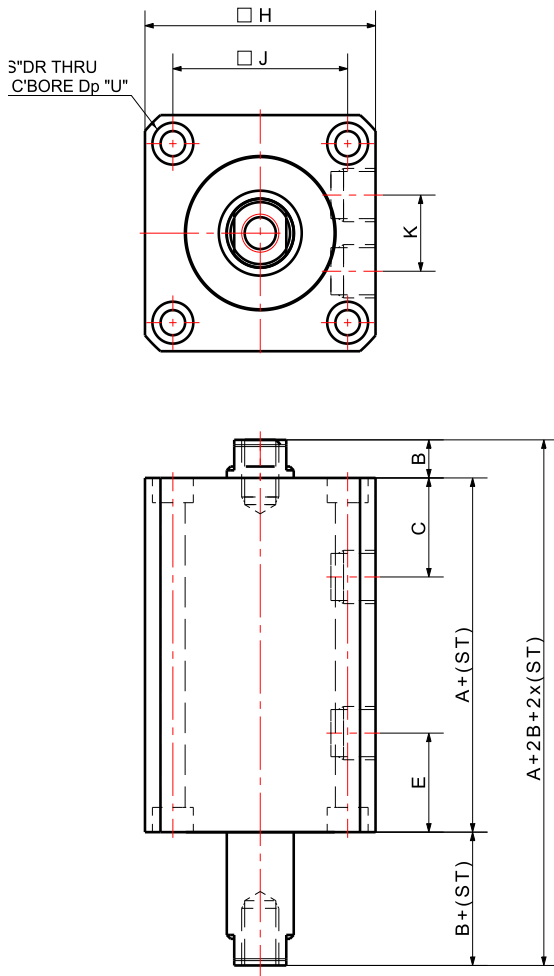

Dimensions

MODEL NO.	DIMENSIONS (mm)																	
	A	B	C	φD	E	F	G	H	J	K	P	φS	φT	U	AA	AB	U	Piston dia.
BDV-28xxD	61	8	23	16	23	M8 x 1.25P	12	56	42	16	1/8	5.5	9.5	5.5	M14 x 1.5P	25	25	φ28
BDV-32xxD	68	10	26	18	26	M10 x 1.5P	15	62	47	20	1/4	5.6	11	7	M16 x 1.5P	25	25	φ32
BDV-40xxD	70	10	27	22.4	27	M12 x 1.75P	20	70	52	20	1/4	9	14	9	M20 x 1.5P	30	30	φ40
BDV-50xxD	75	10	29	28	29	M16 x 2.0P	25	80	58	20	1/4	11	17.5	11	M24 x 1.5P	35	35	φ50
BDV-63xxD	82	13	31.5	35.5	31.5	M20 x 2.5P	33	94	69	20	1/4	14	20	13	M30 x 1.5P	45	45	φ63
BDV-80xxD	92	17	33	45	33	M24 x 3.0P	33	114	86	30	3/8	16	23	16	M39 x 1.5P	60	60	φ80

Vertical Block Clamp Push Type



Features

- | | |
|-------------------------------------|---|
| 1. 단동으로 작동 | 1. Single-acting |
| 2. 스프링 복귀방식 | 2. Spring return method |
| 3. 설치 용이 | 3. Easy installation |
| 4. 작동압력 : 15~250kgf/cm ² | 4. Operating Pressure : 15~250kgf/cm ² |
| 5. 피스톤 속도 : 8~100mm/s | 5. Piston Speed : 8~100mm/s |
| 6. 사용온도 : 0~60°C | 6. Operating Temperature : 0~60°C |
| 7. 유로를 가능한 크게 하시오. | 7. Make piping size as big as possible |

> BPV - 28 15

① ② ③

① Vertical Type ② Piston Diameter(mm) ③ Stroke(mm)

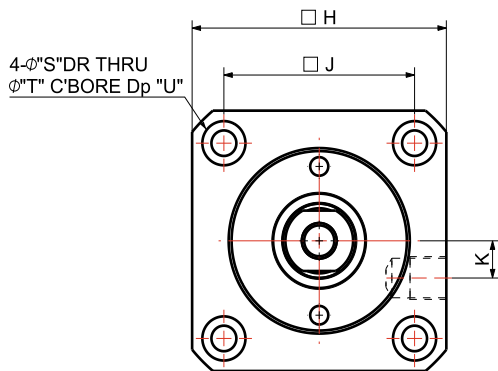

* Air Filter에 수분 빨림 현상이 문제가 되면, 탭과 니플배관으로 수분이 없는 환경으로 회피하십시오.

If the air filter's moisture absorption becomes a problem, avoid it by using a tap and nipple pipe to create a moisture-free environment.

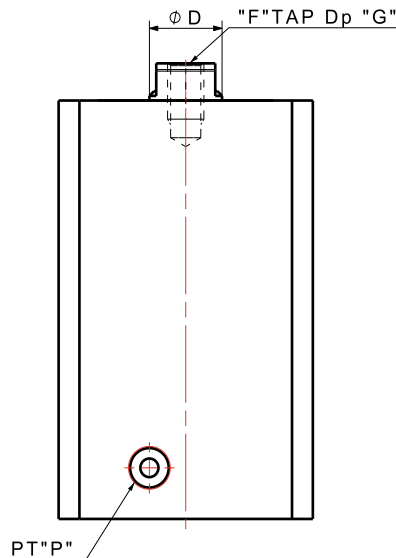
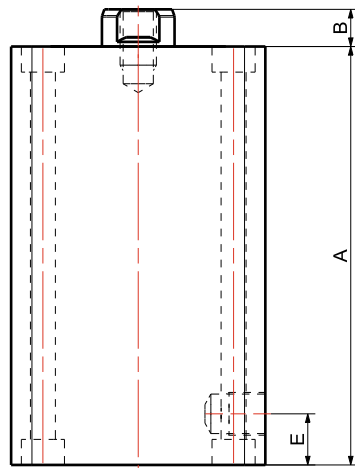

Dimensions

MODEL NO.	DIMENSIONS (mm)														
	A		B	φD	E	F	G	H	J	K	P	φS	φT	U	Piston dia.
BPV-28xx	ST15	ST25	8	16	11	M8 x P1.25	12	56	42	8	1/8	φ5.5	φ9.5	5.5	φ28
BPV-32xx	72	90	10	18	12.5	M10 x P1.5	15	62	47	10	1/4	φ6.6	φ11	6.5	φ32
BPV-40xx	73	93	10	22.4	12	M12 x P1.75	20	70	52	10	1/4	φ9	φ14	9	φ40
BPV-50xx	78	98	10	28	13	M16 x P2.0	25	80	58	10	1/4	φ11	φ18	12	φ50
BPV-63xx	86	106	13	35.5	15	M20 x P2.5	33	94	69	10	1/4	φ14	φ20	13	φ63

Horizontal Block Clamp

Piping Method

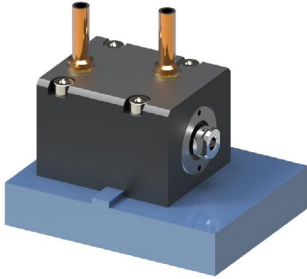

Push/Pull Type

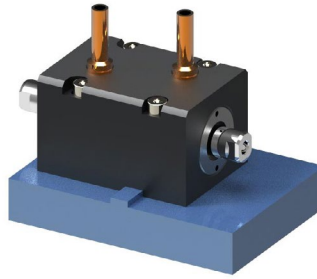

Double Rod Type

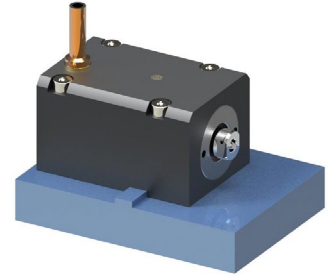

Push Type

Manifold Method

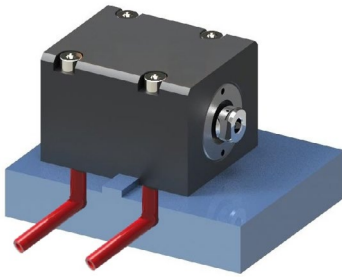

Gasket Type

Rod Shape (재고문의 바랍니다)

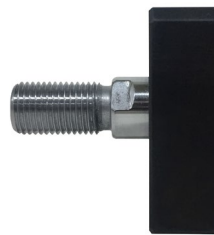

Threaded



Pin Hole

Model No.

BDH-2815D

BDH	-	28	15	D
1		2	3	4

1

Clamp Type

BDH = Block Clamp, Double(Push/Pull)-acting, Horizontal type
 BPH = Block Clamp, Single(Push)-acting, Horizontal type

2

Piston Diameter

ex) 28 = ø28

3

Piston Rod Stroke

ex) 15 = 15mm

4

Type

- > No Sign = Standard
- > C = Threaded Rod
- > P = Pin Hole Rod
- > D = Double Rod
- > DC = Threaded Double Rod
- > G = Gasket
- > GC = Gasket + Threaded Rod
- > GP = Gasket + Pin Hole Rod

Specification

Push/Pull Type

* C/P, G/GC/ GP type도 아래표에 적용됩니다.
 * C/P and G/GC/GP types are applied to below specification.

MODEL NO.	Weight (kg)	Max. Clamping Force(kgf)		Effective Area (cm ²)		Oil Capacity (cm ³)		Operating Pressure Range	Operating Temperature Range				
		Push	Pull	Push	Pull	Push	Pull						
BDH-2010	0.69	790	500	3.1	2.0	3.1	2.0	15~250 kgf/cm ²	0~60°C				
BDH-2015	0.76					4.7	3.0						
BDH-2020	0.82					6.3	4.0						
BDH-2025	0.88					7.9	5.0						
BDH-2030	0.95					9.4	6.0						
BDH-2510	0.94	1,230	840	4.9	3.4	4.9	3.4						
BDH-2515	1.02					7.4	5.1						
BDH-2520	1.09					9.8	6.7						
BDH-2525	1.18					12.3	8.4						
BDH-2530	1.26					14.7	10.1						
BDH-2815	1.5	1,520	1,020	6.1	4.1	9.3	6.2						
BDH-2825	1.7					15.4	10.4						
BDH-2850	2.3					30.8	20.7						
BDH-3215	1.8					2,000	1,370			8.0	5.5	12.0	8.2
BDH-3225	2.1											20.1	13.7
BDH-3250	2.8	40.2	27.5										
BDH-4015	2.3	3,120	2,150	12.5	8.6							18.9	12.9
BDH-4025	2.5											31.4	21.6
BDH-4050	3.3					62.8	43.1						
BDH-5015	3.3					4,950	3,400			19.6	13.4	49.5	20.2
BDH-5025	3.6							49.1	33.7				
BDH-5050	4.5	98.2	67.4										
BDH-6315	4.7	7,770	5,320	31.1	21.3			46.8	31.8				
BDH-6325	5.2							78.0	53.2				
BDH-6350	6.3					155.9	106.4						
BDH-8015	10.5					12,550	8,600	50.2	34.4	75.4	51.5		
BDH-8025	11.5									125.7	85.9		
BDH-8050	14.3	251.4	171.8										
BDH-10050	19.3	19,630	13,470	78.5	53.9					392.5	269.5		
BDH-10075	22.6									588.8	404.3		
BDH-100100	25.8					785.0	539.0						
BDV-12550	31.7					30,670	22,380	122.7	89.5	613.5	447.5		
BDV-12575	36.2									920.3	671.3		
BDV-125100	40.7	1,227.0	895.0										

Push/Pull Double Rod Type

* DC type도 아래표에 적용됩니다.
 * DC type is applied to below specification.

MODEL NO.	Max. Clamping Force(kgf)		Effective Area (cm ²)		Oil Capacity (cm ³)		Weight (kg)	Operating Pressure Range	Operating Temperature Range
	Push	Pull	Push	Pull	Push	Pull			
BDH-2815D	1,020		4.1		6.2	1.8	15~250 kgf/cm ²	0~60°C	
BDH-2825D					10.4	2.0			
BDH-2850D					20.7	2.7			
BDH-3215D	1,370		5.5		8.2	2.0			
BDH-3225D					13.7	2.7			
BDH-3250D					27.5	3.5			
BDH-4015D	2,150		8.6		12.9	2.7			
BDH-4025D					21.6	3.0			
BDH-4050D					43.1	4.1			
BDH-5015D	3,400		13.6		20.2	4.0			
BDH-5025D					33.7	4.6			
BDH-5050D					67.4	5.6			
BDH-6315D	5,320		21.3		31.8	6.5			
BDH-6325D					53.2	7.3			
BDH-6350D					106.4	9.0			
BDH-8015D	8,600		34.4		51.5	12.7			
BDH-8025D					85.9	13.8			
BDH-8050D					171.8	15.6			

Push Type

MODEL NO.	Max. Clamping Force(kgf)	Effective Area (cm ²)	Oil Capacity (cm ³)	Weight (kg)	Operating Pressure Range	Operating Temperature Range
	Push	Push	Push			
BPH-2815	1,520	6.1	9.3	1.7	15~250 kgf/cm ²	0~60°C
BPH-2825			15.4	1.9		
BPH-3215	2,000	8.0	12.0	1.9		
BPH-3225			20.1	2.4		
BPH-4015	3,120	12.5	18.9	2.5		
BPH-4025			31.4	3.0		
BPH-5015	4,950	19.8	29.5	3.6		
BPH-5025			49.1	5.0		
BPH-6315	7,770	31.1	46.8	5.7		
BPH-6325			78.0	7.0		

Horizontal Block Clamp Push/Pull Type



Features

- | | |
|-------------------------------------|---|
| 1. 복동으로 작동 | 1. Double-acting |
| 2. 다양한 사이즈 | 2. Various sizes |
| 3. 설치 용이 | 3. Easy installation |
| 4. 작동압력 : 15~250kgf/cm ² | 4. Operating Pressure : 15~250kgf/cm ² |
| 5. 피스톤 속도 : 8~100mm/s | 5. Piston Speed : 8~100mm/s |
| 6. 사용온도 : 0~60°C | 6. Operating Temperature : 0~60°C |

> BDH - 20 10 BDH - 20 10 C BDH - 20 10 P
 ① ② ③ ① ② ③ ④ ① ② ③ ④

① Horizontal Type ② Piston Diameter(mm) ③ Stroke(mm)
 ④ Threaded Rod, Pin Hole Rod

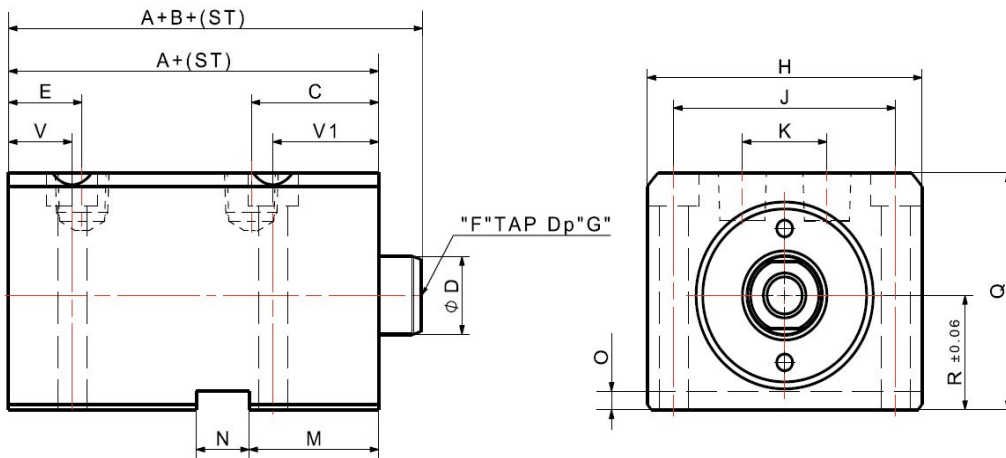
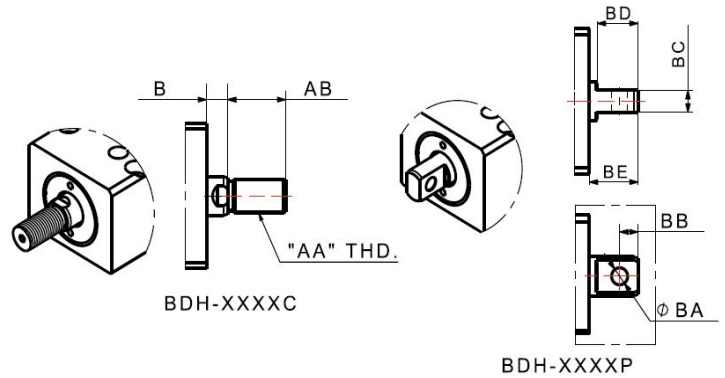
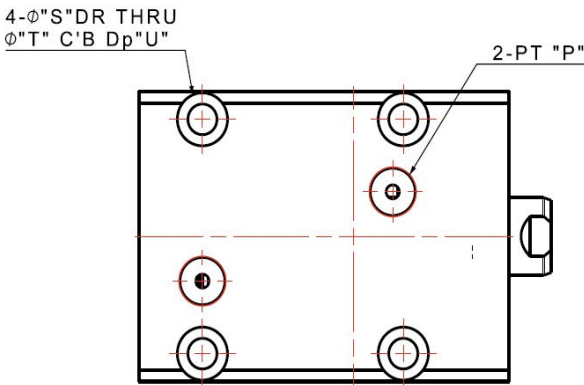

* BDH-20□□ 제품들은 경우에 따라 K치수가 0인 제품이 출고될 수 있음. 배관 시 문제가 된다면 발주 전에 확인바랍니다.

BDV-20□□ products may sometimes be shipped with a "K" dimension of 0. If this could cause issues with piping, please check before placing an order.

Dimensions

MODEL NO.	DIMENSIONS (mm)																												
	A	B	C	φD	E	F	G	H	J	K	M	N	O	P	Q	R	φS	φT	U	V	V1	AA	AB	BA	BB	BC	BD	BE	Piston dia.
BDH-20xx	43	8	20.5	12	12	M8x1.25P	16	45	35	12	22.5	10	3.3	1/8	40	18	5.5	9.5	6	12	18	M10x1.25P	20	φ6	7	8	15.5	18.5	φ20
BDH-25xx	45	8	22	14	12	M8x1.25P	16	52	42	16	24.5	10	3.3	1/8	42.5	20.5	5.5	9.5	6	12	20	M12x1.25P	22	φ6	7	8	15.5	18.5	φ25
BDH-28xx	50	8	23	16	12	M8x1.25P	12	62	50	16	25	10	3.3	1/8	52	24	6.6	11	6.5	12	20	M14x1.5P	25	φ8	8	12	20.5	23.5	φ28
BDH-32xx	54	10	26	18	12	M10x1.5P	15	70	56	20	28	12	3.3	1/4	56	25	9	14	9	10	20	M16x1.5P	25	φ8	9	14	21.5	24.5	φ32
BDH-40xx	55	10	27	22.4	12	M12x1.75P	20	80	62	20	28	12	3.3	1/4	64	29	11	17.5	11	12	20	M20x1.5P	30	φ10	11	16	25.5	28.5	φ40
BDH-50xx	60	10	28	28	13	M16x2.0P	25	94	74	20	29	14	3.8	1/4	74	34	14	20	13	13	20	M24x1.5P	35	φ12	13	20	29.5	32.5	φ50
BDH-63xx	67	13	31.5	35.5	15	M20x2.5P	33	114	90	20	31	16	4.3	1/4	89	42	16	23	16	15	20	M30x1.5P	45	φ16	17	25	35.5	38.5	φ63
BDH-80xx	78	17	33	45	20	M24x3.0P	33	142	114	30	32	20	4.9	3/8	109	52	18	26	18	20	20	M39x1.5P	60	φ18	20	32	42.5	45.5	φ80
BDH-100xx	88	20	42	56	23	M36x4.0P	40	164	134	46	40	20	5	3/8	133	65	20	31	20	23	26								φ100
BDH-125xx	102	25	43	65	25	M42x4.5P	45	196	164	52	40	20	5	1/2	163	80	21	31	22	23	26								φ125

Horizontal Block Clamp Push/Pull Gasket Type

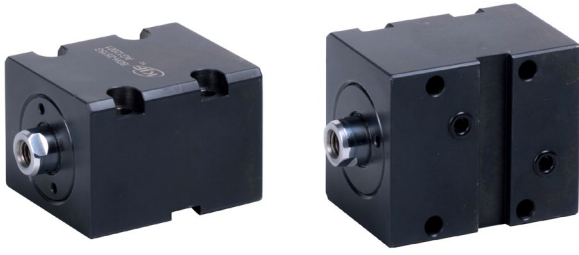

Features

- | | |
|-------------------------------------|---|
| 1. 복동으로 작동 | 1. Double-acting |
| 2. 가스켓 타입 포트 | 2. Gasket Type Port |
| 3. 설치 용이 | 3. Easy installation |
| 4. 작동압력 : 15~250kgf/cm ² | 4. Operating Pressure : 15~250kgf/cm ² |
| 5. 피스톤 속도 : 8~100mm/s | 5. Piston Speed : 8~100mm/s |
| 6. 사용온도 : 0~60°C | 6. Operating Temperature : 0~60°C |

* Threaded Rod와 Pin Hole Rod Type 가능합니다.
* Threaded Rod and Pin Hole Rod Type are available.

> **BDH-20 10 G** **BDH-20 10 GC** **BDH-20 10 GP**
 ① ② ③ ④ ① ② ③ ④ ① ② ③ ④

① Horizontal Type ② Piston Diameter(mm) ③ Stroke(mm)
 ④ Gasket, Gasket + Threaded Rod, Gasket + Pin Hole Rod

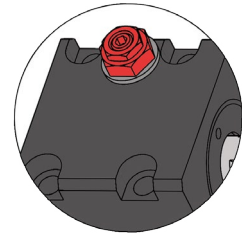
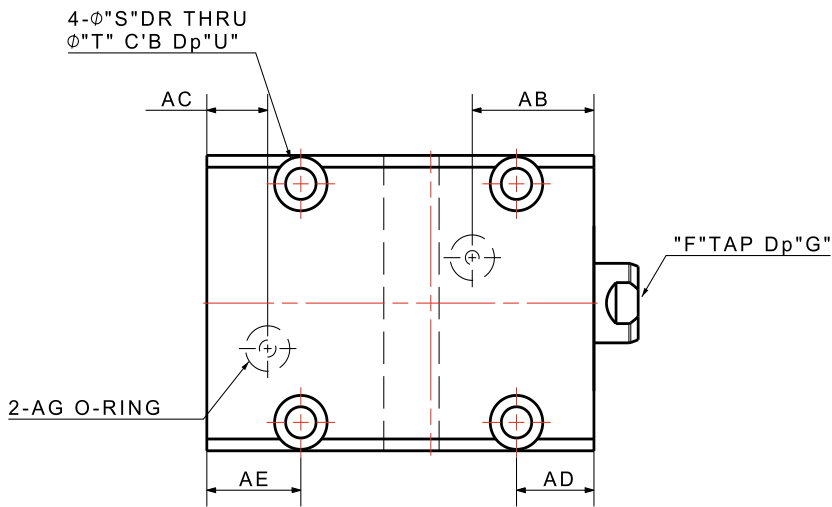

유량조절밸브 장착타입은
주문제작으로 가능함.
Flow Control Valve Type is
available as customized.

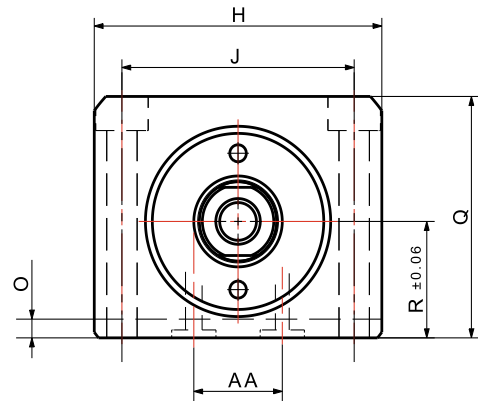
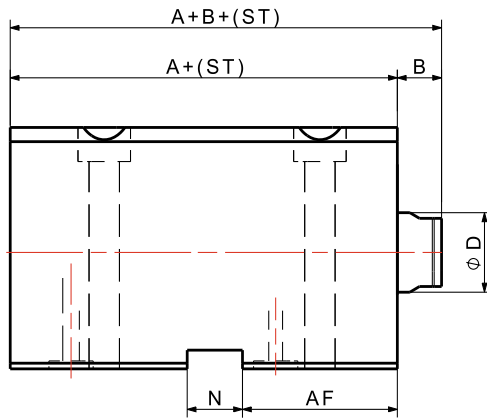

Dimensions

MODEL NO.	DIMENSIONS (mm)																					
	A	B	øD	F	G	H	J	N	O	Q	R	øS	øT	U	AA	AB	AC	AD	AE	AF	AG	Piston dia.
BDH-20xxG	43	8	12	M8 x 1.25P	16	45	35	10	3.3	40	18	5.5	9.5	6	14	20.5	9	13	15	26	P5	ø20
BDH-25xxG	45	8	14	M8 x 1.25P	16	52	42	10	3.3	42.5	20.5	5.5	9.5	6	16	22	11	14	17	28	P5	ø25
BDH-28xxG	50	8	16	M8 x 1.25P	12	62	50	10	3.3	52	24	6.6	11	6.5	18	23	11	14	18	30	P6	ø28
BDH-32xxG	54	10	18	M10 x 1.5P	15	70	56	12	3.3	56	25	9	14	9	20	26	10	14	18	33	P7	ø32
BDH-40xxG	55	10	22.4	M12 x 1.75P	20	80	62	12	3.3	64	29	11	17.5	11	20	24	10	14	19	31	P7	ø40
BDH-50xxG	60	10	28	M16 x 2.0P	25	94	74	14	3.8	74	34	14	20	13	20	26	13	14	20	33	P7	ø50



Horizontal Block Clamp Push/Pull Double Rod Type

Features

- | | |
|-------------------------------------|---|
| 1. 양로드 타입 | 1. Double rods type |
| 2. 다양한 사이즈 | 2. Various sizes |
| 3. 복동으로 작동 | 3. Double-acting |
| 4. 작동압력 : 15~250kgf/cm ² | 4. Operating Pressure : 15~250kgf/cm ² |
| 5. 피스톤 속도 : 8~100mm/s | 5. Piston Speed : 8~100mm/s |
| 6. 사용온도 : 0~60°C | 6. Operating Temperature : 0~60°C |

> **BDH - 28 15 D** **BDH - 28 15 DC**

① ② ③ ④ ① ② ③ ④

- ① Horizontal Type ② Piston Diameter(mm) ③ Stroke(mm)
④ Double Rod Type, Double + Threaded Rod

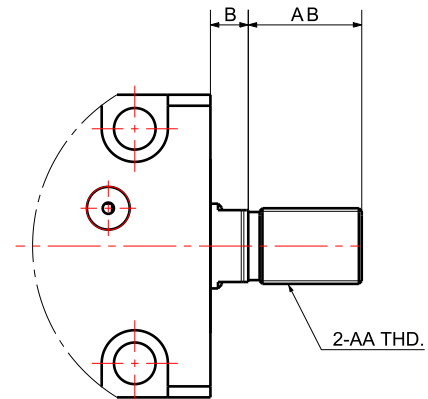
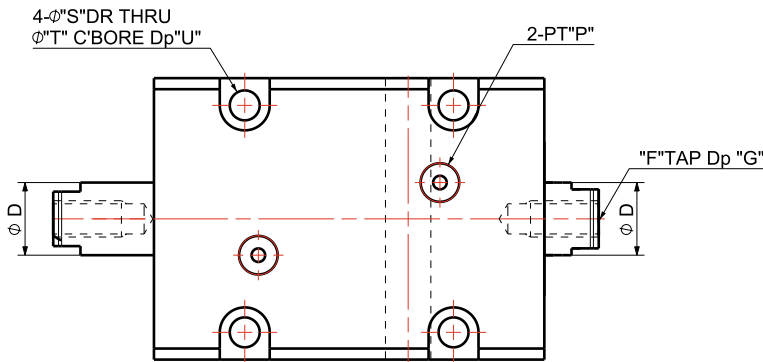

DC TYPE

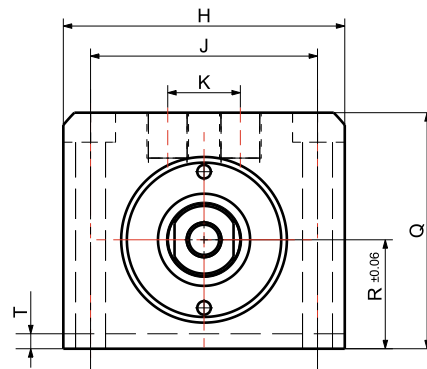
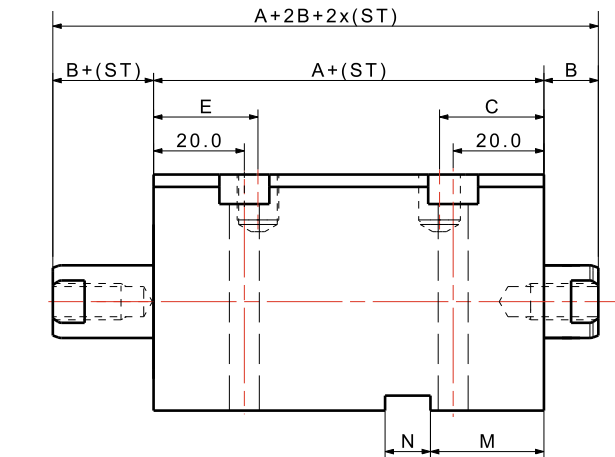

Dimensions

MODEL NO.	DIMENSIONS (mm)																					
	A	B	C	øD	E	F	G	H	J	K	M	N	O	P	Q	R	øS	øT	U	AA	AB	Piston dia.
BDH-28xxD	61	8	23	16	23	M8 x 1.25P	12	62	50	16	25	10	3.3	1/8	52	24	6.6	11	6.5	M14 x 1.5P	25	ø28
BDH-32xxD	68	10	26	18	26	M10 x 1.5P	15	70	56	20	28	12	3.3	1/4	56	25	9	14	9	M16 x 1.5P	25	ø32
BDH-40xxD	70	10	27	22.4	27	M12 x 1.75P	20	80	62	20	28	12	3.3	1/4	64	29	11	17.5	11	M20 x 1.5P	30	ø40
BDH-50xxD	75	10	29	28	29	M16 x 2.0P	25	94	74	20	29	14	3.8	1/4	74	34	14	20	13	M24 x 1.5P	35	ø50
BDH-63xxD	82	13	31.5	35.5	31.5	M20 x 2.5P	33	114	90	20	31	16	4.3	1/4	89	42	16	23	16	M30 x 1.5P	45	ø63
BDH-80xxD	92	17	33	45	33	M24 x 3.0P	33	142	114	30	32	20	4.9	3/8	109	52	18	26	18	M39 x 1.5P	60	ø80

Horizontal Block Clamp Push Type



Features

- | | |
|-------------------------------------|---|
| 1. 단동으로 작동 | 1. Single-acting |
| 2. 스프링 복귀방식 | 2. Spring return method |
| 3. 설치 용이 | 3. Easy installation |
| 4. 작동압력 : 15~250kgf/cm ² | 4. Operating Pressure : 15~250kgf/cm ² |
| 5. 피스톤 속도 : 8~100mm/s | 5. Piston Speed : 8~100mm/s |
| 6. 사용온도 : 0~60°C | 6. Operating Temperature : 0~60°C |
| 7. 유로는 가능한 크게 하시오. | 7. Make piping size as big as possible |

> BPH - 28 15

① ② ③

① Horizontal Type ② Piston Diameter(mm) ③ Stroke(mm)

4-∅"S"DR THRU
∅"T" C'BORE Dp"U"

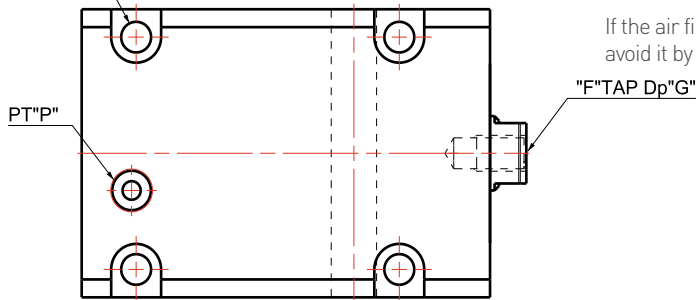

* Air Filter에 수분 빨림 현상이 문제가 되면,
탭과 니플배관으로 수분이 없는 환경으로 회피하십시오.

If the air filter's moisture absorption becomes a problem,
avoid it by using a tap and nipple pipe to create a moisture-free environment.

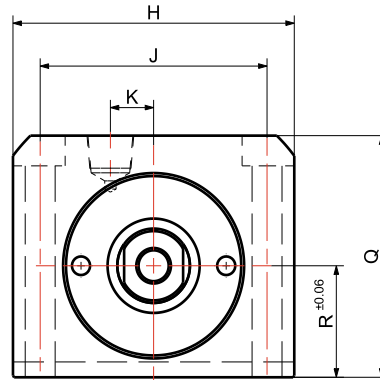
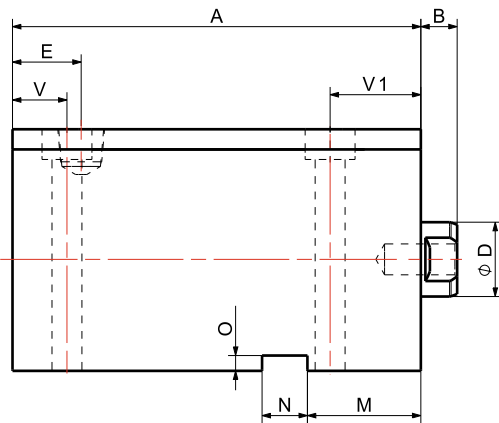

Dimensions

MODEL NO.	DIMENSIONS (mm)																					
	A	B	∅D	E	F	G	H	J	K	M	N	O	P	Q	R	∅S	∅T	U	V	V1	Piston dia.	
BPH-28xx	72	90	8	16	11	M8 x P1.25	12	62	50	8	25	10	3.3	1/8	52	24	∅6.6	∅11	6.5	12	20	∅28
BPH-32xx	72	90	10	18	12.5	M10 x P1.5	15	70	56	10	28	12	3.3	1/4	56	25	∅9	∅14	8.6	10	20	∅32
BPH-40xx	73	93	10	22.4	12	M12 x P1.75	20	80	62	10	28	12	3.3	1/4	64	29	∅11	∅17.5	11	12	20	∅40
BPH-50xx	78	98	10	28	13	M16 x P2.0	25	94	74	10	29	14	3.8	1/4	74	34	∅14	∅20	13	13	20	∅50
BPH-63xx	86	106	13	35.5	15	M20 x P2.5	33	114	90	10	31	16	4.3	1/4	89	42	∅16	∅23	16	15	20	∅63

Built-In Clamp Introduction

빌트인 클램프는 사이즈를 최소로 축소한 제품으로 단동으로 작동되고 몸통에 나사가 있습니다. 로케이션 실린더로 사용하기에도 좋고 클램프 설치 환경이 매우 열악할 때 적용하면 좋습니다.



Built-In clamp is a product that has minimized its sizes.
It works with single-acting with a screw on the body.
Bluit-in clamp can be used as a location cylinder or when clamp installation environment is extremely poor.

Structure

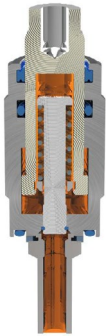

Application

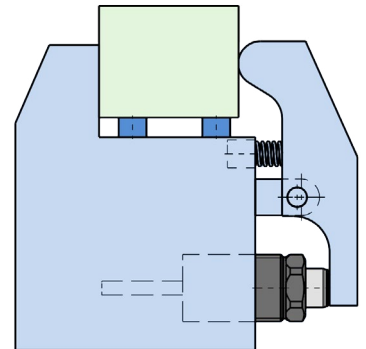
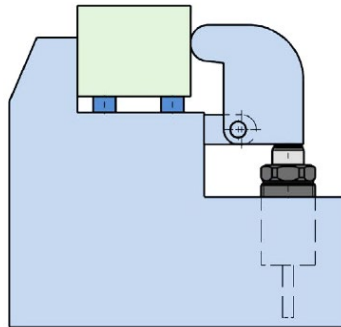
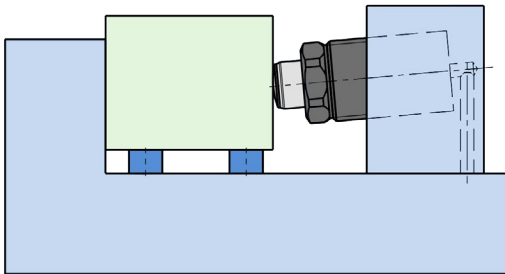
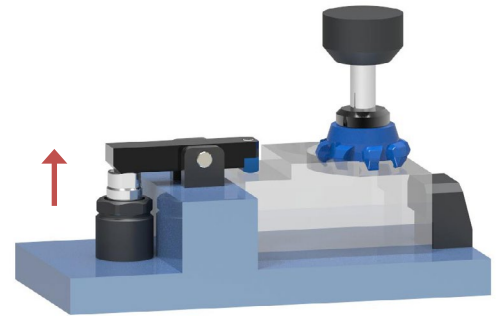
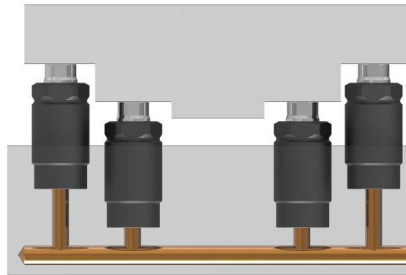

Various Sizes



Model No.

MTB-1105R

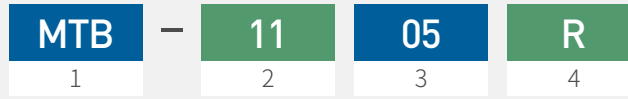

1 Clamp Type
MTB = Built-In Clamp

2 Piston Diameter
ex) 11 = $\phi 11$

3 Piston Rod Stroke
ex) 05 = 5mm

4 Rod Shape
R = Round
No Sign = Standard

Specification

* For Max. Operating Pressure

MODEL NO.	Type	Weight (kg)	Max. Clamping Force (kgf)	Oil Capacity Push (cm ³)	Effective Area (cm ²)	Stroke (mm)	Piston Diameter (mm)	Tightening Torque (kgm·cm)*	Operating Pressure Range	Operating Temperature Range
MTB-0805	R	0.02	126	0.25	0.50	5	$\phi 8$	120	15-250 kgf/cm ²	0-60°C
MTB-0810	R	0.03	126	0.50	0.50	10	$\phi 8$	120		
MTB-1105□	R	0.03	240	0.47	0.95	5	$\phi 11$	160		
MTB-1210□	No Sign	0.11	280	1.13	1.13	10	$\phi 12$	400		
	R	0.11								
MTB-1412□	No Sign	0.13	380	1.85	1.54	12	$\phi 14$	630		
	R	0.13								
MTB-1814□	No Sign	0.22	640	3.56	2.54	14	$\phi 18$	1,000		
	R	0.21								
MTB-2215□	No Sign	0.38	950	5.70	3.80	15	$\phi 22$	2,500		
	R	0.36								
MTB-3020□	No Sign	0.78	1,770	14.13	7.07	20	$\phi 30$	4,000		
	R	0.76								
MTB-3625□	No Sign	1.27	2,540	25.43	10.17	25	$\phi 36$	6,300		
	R	1.22								
MTB-4525□	No Sign	1.87	3,970	39.74	15.90	25	$\phi 45$	10,000		
	R	1.78								



- * 과도한 힘으로 결합시 불량 의 원인이 됨.
- * Assembly with excessive force will cause defect.

Built-In Clamp Round Rod Type

Features

1. 내경에 비해 피스톤 로드의 외경이 매우 굵어서 튼튼하게 사용할 수 있다.
 2. 스크로크에 비해 전장이 짧아 좁은 공간에 설치할 수 있다.
 3. 실린더끼리 가장 가깝게 설치할 수 있고 스프링으로 복귀된다.
 4. 매니홀더식으로 설치하면 배관 부담을 쉽게 벗어 날 수 있다.
 5. 작동압력 : 15~250kgf/cm²
 6. 사용온도 : 0~60°C
 7. 유로는 가능한 크게 하시오.
1. The outer diameter of the piston rod is very thick compared to the inner diameter. Therefore, it can be used stably.
 2. The total length is shorter compared to stroke and can be installed in a crawlspace.
 3. The cylinders can be installed closest to each other and return to the spring.
 4. You can be ease of piping burden if installed in the manifold method.
 5. Operating Pressure : 15~250kgf/cm²
 6. Operating Temperature : 0~60°C
 7. Make piping size as big as possible.

> MTB - 11 05 R

① ② ③

- ① Piston diameter(mm) ② Total stroke(mm) ③ Round Rod

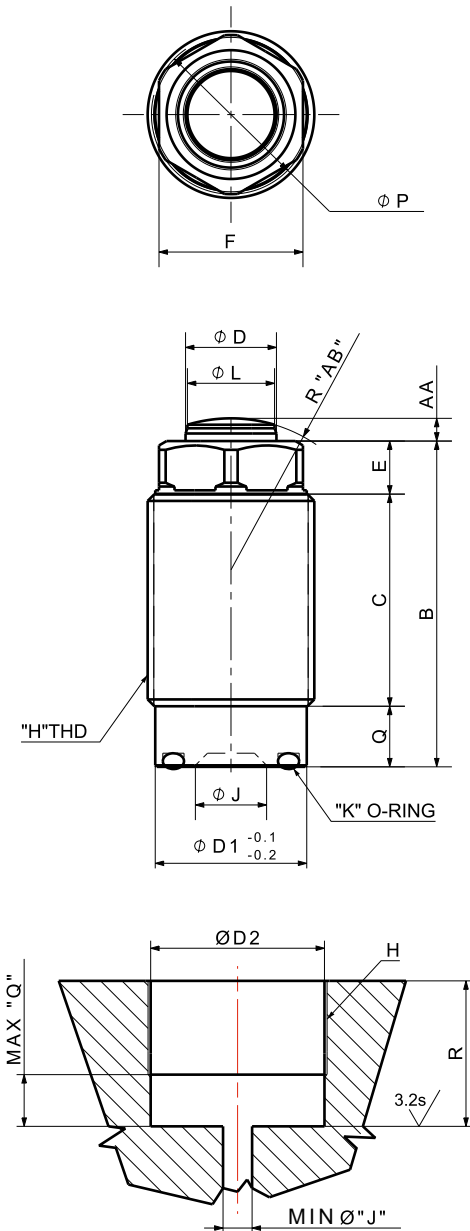

MOUNTING AREA

Dimensions

MODEL NO.	MTB-1105R	MTB-1210R	MTB-1412R	MTB-1814R	MTB-2215R	MTB-3020R	MTB-3625R	MTB-4525R
B	27	43	44	46	54.5	72	75.5	78
C	19	28	26	27	35.5	47	48.5	48
øD	6	12	14	18	22.4	30	35.5	45
øD1	14	20	22	28	34.3	43.3	52.6	62.6
øD2	14.5	20.5	22.5	28.5	34.5	43.5	53	63
E	4	7	8	9	11	15	15	17
F	12	19	22	27	32	41	50	60
H	M16 x 1.5P	M22 x 1.5P	M24 x 1.5P	M30 x 1.5P	M36 x 1.5P	M45 x 1.5P	M55 x 2.0P	M65 x 2.0P
J	10	11	12	15	18	24	30	40
K	P10A	P14	P16	P22	AS568-121	P32	P40	P50
L	-	11.5	13	17	22.4	28	35.5	45
O	-	5.5	5.5	7	9.5	9.5	11	13
P	-	21	24	29	35.5	45	55	66
Q	4	8	10	10	8	10	12	13
R	8~23	16~36	20~36	20~37	16~43	20~57	24~60	26~61
AA	1	3	3	3.5	4	5	6	7
AB	R12	R20	R25	R32	R40	R60	R60	R70



- * 과도한 힘으로 결합시 불량 의 원인이 됨.
- * Assembly with excessive force will cause defect.

Built-In Clamp Standard Type

Features

1. 내경에 비해 피스톤 로드의 외경이 매우 굵어서 튼튼하게 사용할 수 있다.
 2. 스크로크에 비해 전장이 짧아 좁은 공간에 설치할 수 있다.
 3. 실린더끼리 가장 가깝게 설치할 수 있고 스프링으로 복귀된다.
 4. 매니홀더식으로 설치하면 배관 부담을 쉽게 벗어 날 수 있다.
 5. 작동압력 : 15~250kgf/cm²
 6. 사용온도 : 0~60°C
 7. 유로는 가능한 크게 하시오.
1. The outer diameter of the piston rod is very thick compared to the inner diameter. Therefore, it can be used stably.
 2. The total length is shorter compared to stroke and can be installed in a crawlspace.
 3. The cylinders can be installed closest to each other and return to the spring.
 4. You can be ease of piping burden if installed in the manifold method.
 5. Operating Pressure : 15~250kgf/cm²
 6. Operating Temperature : 0~60°C
 7. Make piping size as big as possible.

> MTB - 12 10

① ②

① Piston diameter(mm) ② Total stroke(mm)

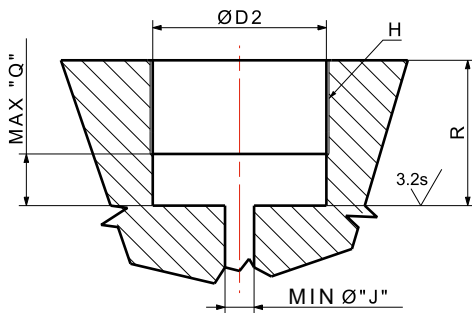
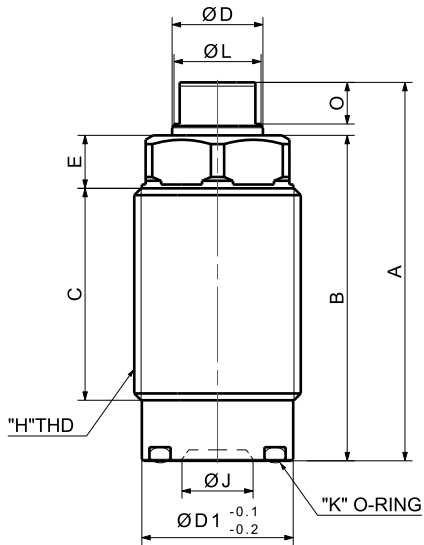
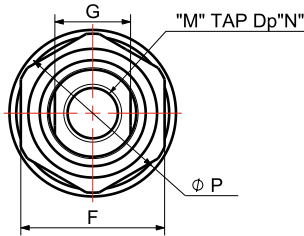

MOUNTING AREA

Dimensions

MODEL NO.	MTB-1210	MTB-1412	MTB-1814	MTB-2215	MTB-3020	MTB-3625	MTB-4525
A	50	52	55	66.5	84	88.5	94
B	43	44	46	54.5	72	75.5	78
C	28	26	27	35.5	47	48.5	48
øD	12	14	18	22.4	30	35.5	45
øD1	20	22	28	34.3	43.3	52.6	62.6
øD2	20.5	22.5	28.5	34.5	43.5	53	63
E	7	8	9	11	15	15	17
F	19	22	27	32	41	50	60
G	10	12	16	19	24	30	36
H	M22x1.5P	M24x1.5P	M30x1.5P	M36x1.5P	M45x1.5P	M55x2.0P	M65x2.0P
J	11	12	15	18	24	30	40
K	P14	P16	P22	AS568-121	P32	P40	P50
L	11.5	13	17	22.4	28	35.5	45
M	M8	M8	M8	M8	M10	M12	M16
N	8	8	8	10	11	12	16
O	5.5	5.5	7	9.5	9.5	11	13
P	21	24	29	35.5	45	55	66
Q	8	10	10	8	10	12	13
R	16-36	20-36	20-37	16-43	20-57	24-60	26-61

Built-In Clamp Round Rod Type



MTB-0805

MTB-0810

- * 과도한 힘으로 결합시 불량 의 원인이 됨.
- * Assembly with excessive force will cause defect.

Features

1. 내경에 비해 피스톤 로드의 외경이 매우 굵어서 튼튼하게 사용할 수 있다.
 2. 스크로크에 비해 전장이 짧아 좁은 공간에 설치할 수 있다.
 3. 실린더끼리 가장 가깝게 설치할 수 있고 스프링으로 복귀된다.
 4. 매니홀더식으로 설치하면 배관 부담을 쉽게 벗어 날 수 있다.
 5. 작동압력 : 15~250kgf/cm²
 6. 사용온도 : 0~60°C
 7. 유로는 가능한 크게 하시오.
1. The outer diameter of the piston rod is very thick compared to the inner diameter. Therefore, it can be used stably.
 2. The total length is shorter compared to stroke and can be installed in a crawlspace.
 3. The cylinders can be installed closest to each other and return to the spring.
 4. You can be ease of piping burden if installed in the manifold method.
 5. Operating Pressure : 15~250kgf/cm²
 6. Operating Temperature : 0~60°C
 7. Make piping size as big as possible.

> MTB - 08 05 R

① ② ③

- ① Piston diameter(mm) ② Total stroke(mm) ③ Round Rod

Application

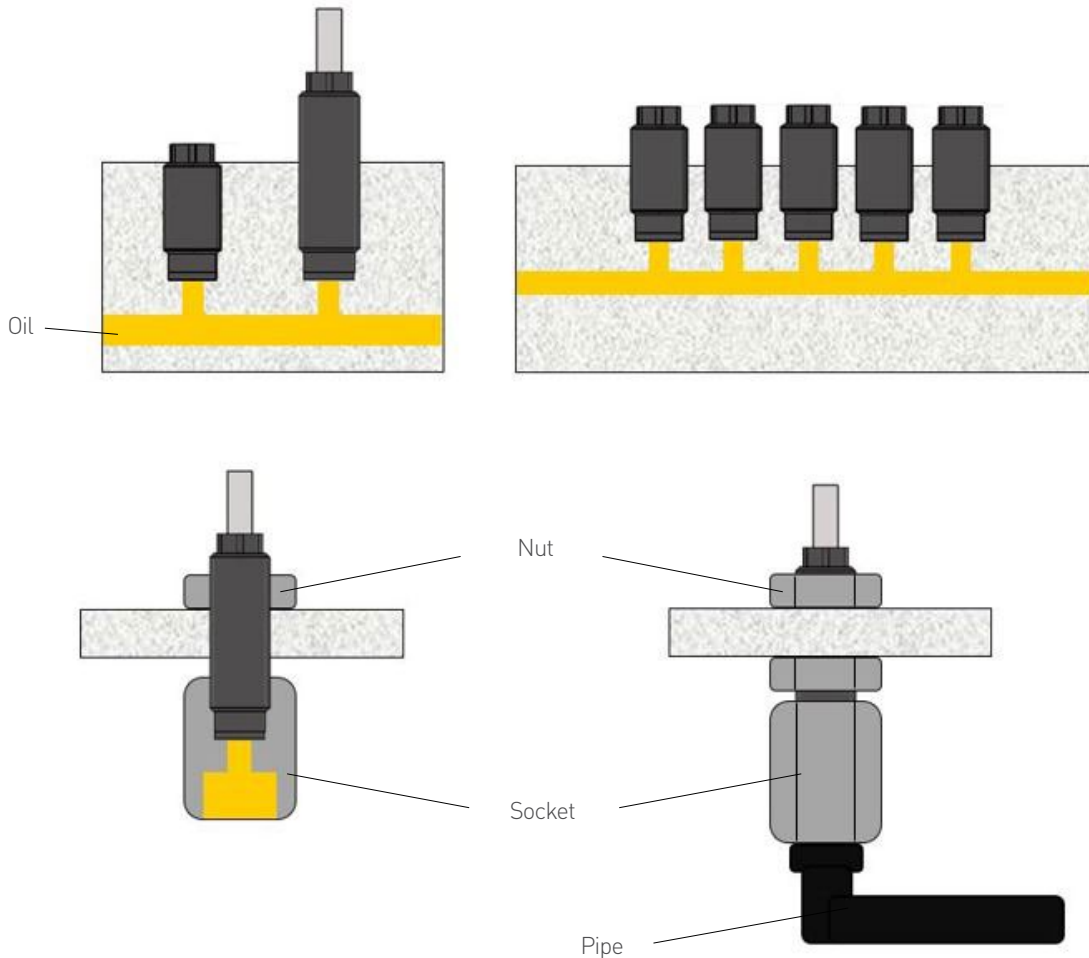

> MTB-0805

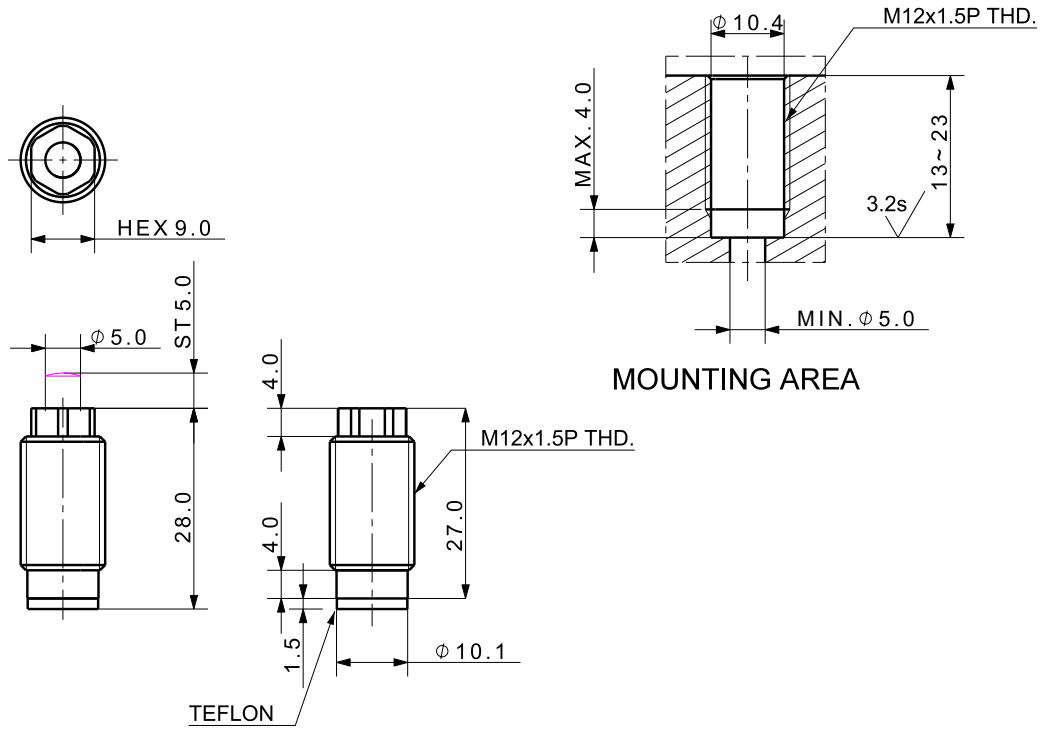

> MTB-0810

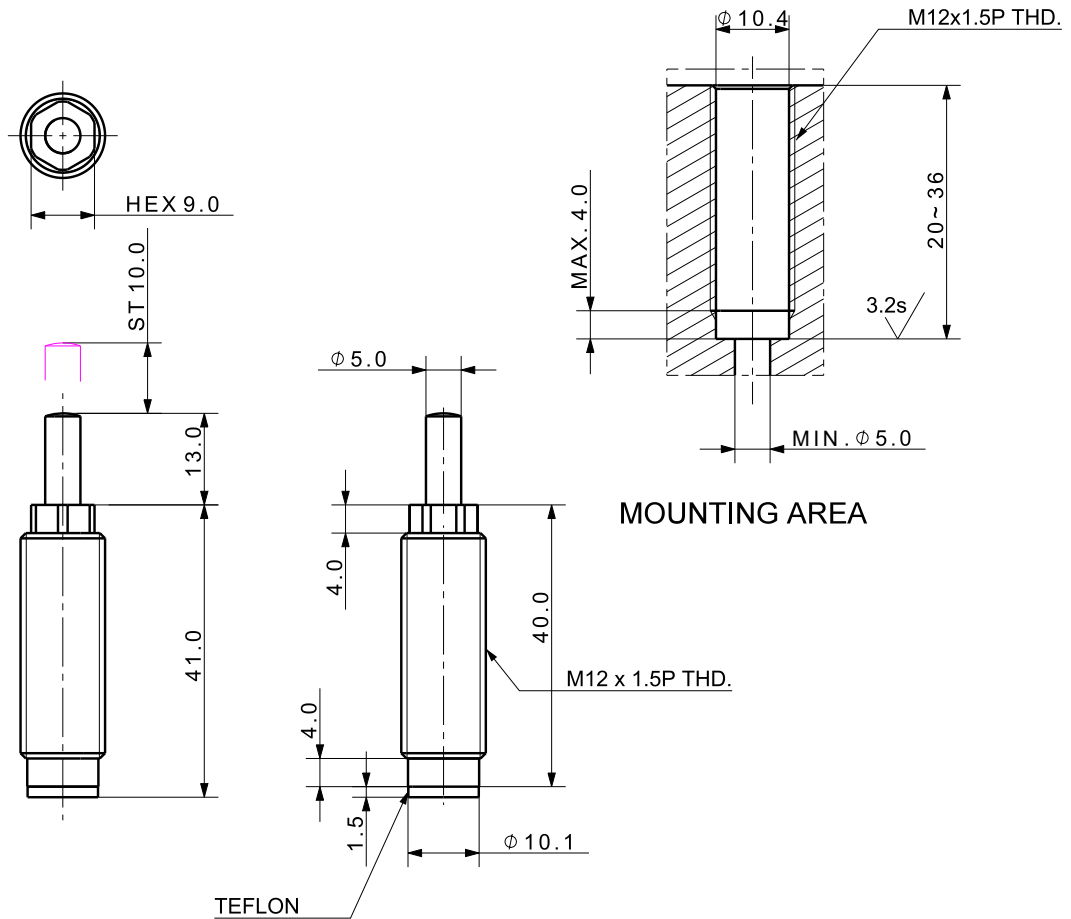

Flange Clamp Introduction

플랜지 클램프는 설치가 쉽고 피스톤 로드가 직선으로 움직이며 배관은 파이프 또는 매니폴드 방식으로 다양하게 할 수 있어서 응용성이 높습니다. 아울러 플로우 컨트롤 밸브를 간편하게 장착할 수 있습니다.

Flange clamp is easy to install and the piston rod moves in a straight line. It has high applicability as the piping can be varied in a pipe or a manifold method.

Flow control valve can also be installed easily.

Top Flange Clamp

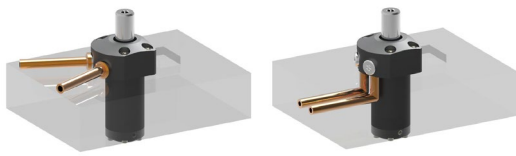

Piping Method

Manifold Method

Bottom Flange Clamp

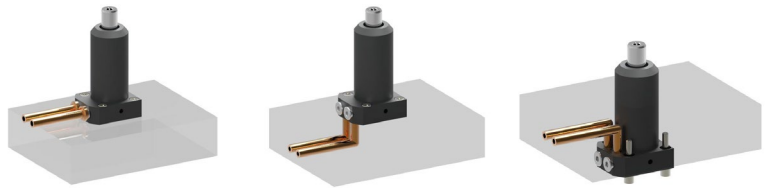

Piping Method

Manifold Method

Application

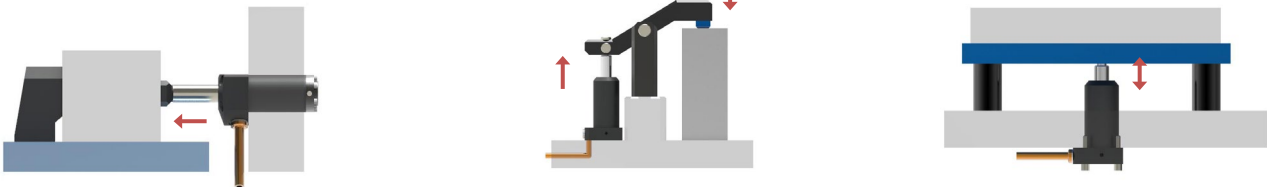

Rod Shape



Top, Standard



Top, Pin Hole



Bottom, Standard



Bottom, Pin Hole

Model No.

SDP-2530GV

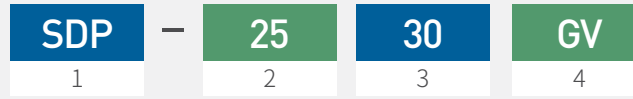

- 1** Clamp Type
SDP = Flange Clamp
- 2** Piston Diameter
ex) 25 = ø25
- 3** Piston Rod Stroke
ex) 30 = 30mm
- 4** Type
 No Sign = Top
 P = Top, Pin Hole Rod
 G = Top, Gasket
 GP = Top, Gasket + Pin Hole Rod
 GV = Top, Gasket + Flow Control Valve
 GPV = Top, Gasket + Pin Hole Rod + Flow Control Valve
 F = Bottom
 FP = Bottom, Pin Hole Rod
 FG = Bottom, Gasket
 FGP = Bottom, Gasket + Pin Hole Rod
 FGV = Bottom, Gasket + Flow Control Valve
 FGPV = Bottom, Gasket + Pin Hole Rod + Flow Control Valve
 FGT = Bottom, Gasket Top
 FGPT = Bottom, Gasket Top + Pin Hole Rod
 FGVT = Bottom, Gasket Top + Flow Control Valve
 FGPVT = Bottom, Gasket Top + Pin Hole Rod + Flow Control Valve

Specification

Top Flange Clamp

MODEL NO.		SDP-2530□			SDP-3037□			SDP-4055□			SDP-5577□		
Type		No Sign	G	GV	No Sign	G	GV	No Sign	G	GV	No Sign	G	GV
		P	GP	GPV	P	GP	GPV	P	GP	GPV	P	GP	GPV
Weight (kg)		1.06	0.99	1.00	1.86	1.80	1.81	3.27	3.14	3.15	6.74	6.36	6.38
		1.05	0.98	0.99	1.85	1.78	1.79	3.25	3.11	3.12	6.72	6.35	6.37
Max. Clamping Force(kgf)	Push	1,230			1,770			3,140			5,940		
	Pull	590			780			1,600			3,530		
Effective Area (cm ²)	Push	4.91			7.07			12.56			23.75		
	Pull	2.36			3.13			6.41			14.13		
Oil Capacity (cm ³)	Push	14.72			26.14			69.08			182.84		
	Pull	7.09			11.57			35.23			108.80		
Piston Diameter (mm)		ø25			ø30			ø40			ø55		
Operating Pressure Range		15-250 kgf/cm ²											
Operating Temperature Range		0-60°C											

Bottom Flange Clamp

MODEL NO.		SDP-2530□					SDP-3037□					SDP-4055□					SDP-5577□				
Type		F	FG	FGV	FGT	FGVT	F	FG	FGV	FGT	FGVT	F	FG	FGV	FGT	FGVT	F	FG	FGV	FGT	FGVT
		FP	FGP	FGPV	FGPT	FGPVT	FP	FGP	FGPV	FGPT	FGPVT	FP	FGP	FGPV	FGPT	FGPVT	FP	FGP	FGPV	FGPT	FGPVT
Weight (kg)		1.23	1.24	1.25	1.24	1.25	2.22	2.25	2.26	2.24	2.25	3.96	3.99	4.01	3.98	3.99	8.24	8.29	8.31	8.29	8.31
		1.22	1.23	1.24	1.23	1.24	2.20	2.23	2.24	2.23	2.24	3.94	3.98	3.99	3.98	3.99	8.23	8.28	8.30	8.28	8.30
Max. Clamping Force(kgf)	Push	1,230					1,770					3,140					5,940				
	Pull	590					780					1,600					3,530				
Effective Area (cm ²)	Push	4.91					7.07					12.56					23.75				
	Pull	2.36					3.13					6.41					14.13				
Oil Capacity (cm ³)	Push	14.72					26.14					69.08					182.84				
	Pull	7.09					11.57					35.23					108.80				
Piston Diameter (mm)		ø25					ø30					ø40					ø55				
Operating Pressure Range		15-250 kgf/cm ²																			
Operating Temperature Range		0-60°C																			



※ 유량조절밸브 필요 시, 설치위치에 대해 확인 요청 바람.

Top Flange Clamp Standard & Gasket Type

Features

1. 피스톤로드가 직선으로 작동
2. 작동압력 : 15~250kgf/cm²
3. 사용온도 : 0~60°C

1. Piston rod moves in linear.
2. Operating Pressure : 15~250kgf/cm²
3. Operating Temperature : 0~60°C

- > SDP - 25 30
- SDP - 25 30 G
- SDP - 25 30 GV
- SDP - 25 30 P
- SDP - 25 30 GP
- SDP - 25 30 GPV

- ① Double acting(Linear move)
 - ② Piston Diameter(mm)
 - ③ Total Stroke(mm)
 - ④ No sign = Standard
- G = Gasket
 GV = Gasket + Side Valve
 P = Pin Hole Rod
 GP = Gasket + Pin Hole Rod
 GPV = Gasket Pin Hole Rod + Side Valve

Dimensions

MODEL NO.	SDP-2530□	SDP-3037□	SDP-4055□	SDP-5577□
A	126	153	172	219
B	156	190	227	296
C	99	123	140	182
∅D	25	30	40	55
∅D1	37	45.5	57	76
∅D2	18	22.4	28	35
F	30	35	40	45
G	21	22	26	30
G1	20	23	31	35
H	12	25	22	22
J	PT 1/8	PT 1/4	PT 1/4	PT 3/8
L	27	30	32	37
M	M8 x 1.25P	M10 x 1.5P	M12 x 1.75P	M16 x 2.0P
O	M40 x 1.5P	M48 x 1.5P	M60 x 1.5P	M80 x 2.0P
P	19	27	35	44.5
Q	55	54	70	89
R	25	42	54	70
S	42	42	54	70
T	6.5	6.5	9	11
U	11	11	14	17
V	15	15	20	25
X	23	25.5	35	43
Y	P6	P6	P6	P10
Z	32	36.5	48.5	59
BA	7.1	7.2	7.2	5.7
BB	13.7	16.8	16.8	15.3
BC	3.9	3.3	3.3	1.8
AA	∅8.0	∅10.0	∅12.0	∅16.0
AB	10	12	13	17
AC	∅17.0	∅21.0	∅26.5	∅33.0
AD	12	14	18	22
AE	22.5	26	30	37
AF	27	30	34	41

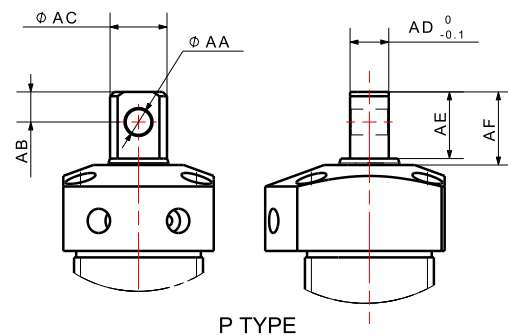
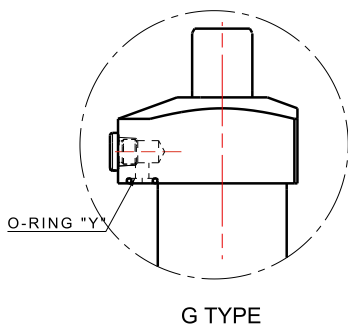
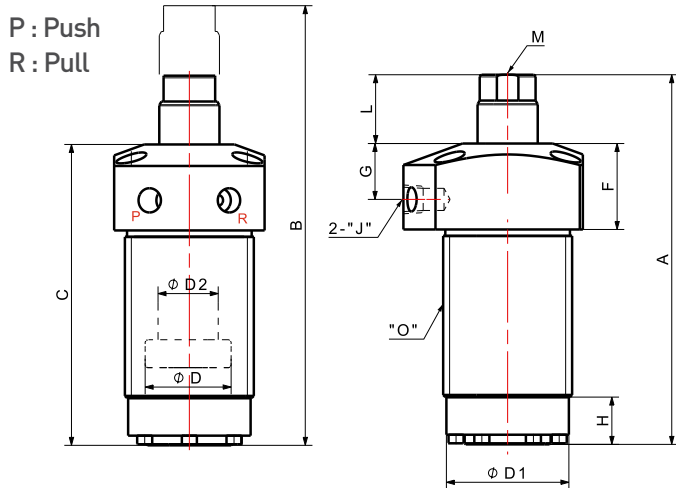
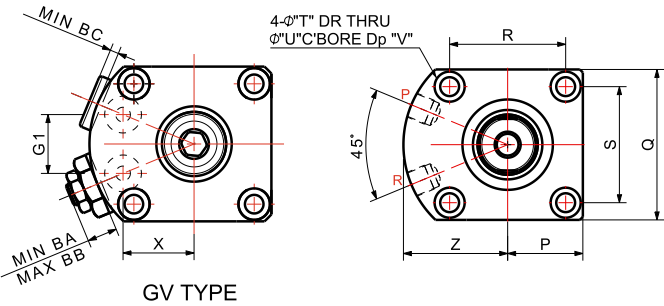



※ 유량조절밸브 필요 시, 설치위치에 대해 확인 요청 바람.

Bottom Flange Clamp Standard & Gasket Type

Features

- | | |
|-------------------------------------|---|
| 1. 하부 플랜지 배관 | 1. Bottom flange circuit |
| 2. 작동압력 : 15~250kgf/cm ² | 2. Operating Pressure : 15~250kgf/cm ² |
| 3. 사용온도 : 0~60°C | 3. Operating Temperature : 0~60°C |

- > SDP - 25 30 F
 SDP - 25 30 FG
 SDP - 25 30 FGV
 SDP - 25 30 FGT
 SDP - 25 30 FGVT
 SDP - 25 30 FP
 SDP - 25 30 FGP
 SDP - 25 30 FGPV
 SDP - 25 30 FGPT
 SDP - 25 30 FGPVT
 ① ② ③ ④

- ① Double acting (Linear move)
 ② Piston Diameter (mm)
 ③ Total Stroke (mm)
 ④ F = Bottom Flange,
 FG = Gasket
 FGV = Gasket + Side Valve
 FGT = Gasket Top
 FGVT = Gasket Top + Side Valve
 FP = Pin Hole Rod
 FGP = Gasket + Pin Hole Rod
 FGPV = Gasket + Pin Hole Rod +
 Side Valve
 FGPT = Gasket Top + Pin Hole Rod
 FGPVT = Gasket Top + Pin Hole
 Rod + Side Valve

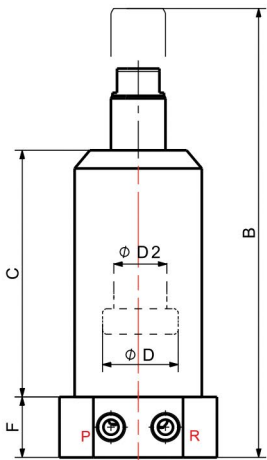
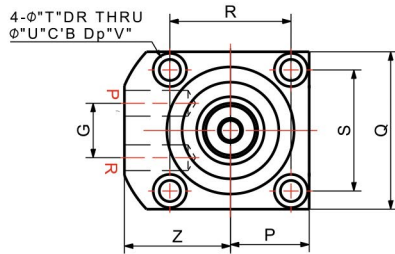

P : Push R : Pull

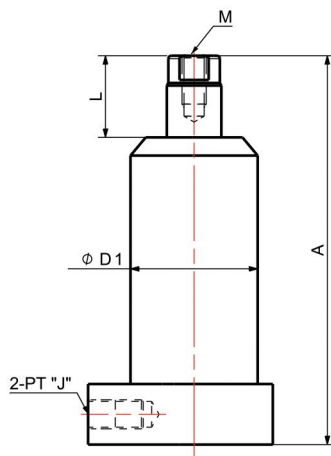

Dimensions

MODEL NO.	SDP-2530F□	SDP-3037F□	SDP-4055F□	SDP-5577F□
A	128.5	153	172	227
B	158.5	190	227	296
C	81.5	98	112	160
φD	25	30	40	55
φD1	42	52	65	65
φD2	18	22.4	28	35
F	20	25	28	30
G1	18	20	24	30
H	12	25	22	22
J	PT 1/8	PT 1/4	PT 1/4	PT 3/8
L	27	30	32	37
M	M8 x 1.25P	M10 x 1.5P	M12 x 1.75P	M16 x 2.0P
P	26	30	40	48.5
Q	52	60	80	97
R	40	46	64	76
S	40	46	64	76
T	7	7	9	11
U	11	11	14	17
V	7	15	9	11
X	26	31	38	47
Y	P6	P6	P6	P7
Z	35	40	50	59
BA	7.1	7.2	7.2	5.7
BB	13.7	16.8	16.8	15.3
BC	3.9	3.3	3.3	1.8
AA	φ8.0	φ10.0	φ12.0	φ16.0
AB	10	12	13	17
AC	φ17.0	φ21.0	φ26.5	φ33.0
AD	12	14	18	22
AE	22.5	26	30	37
AF	27	30	34	41

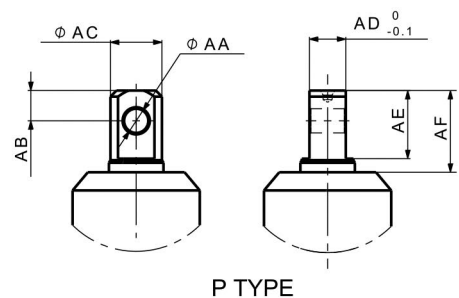
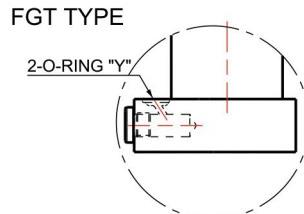
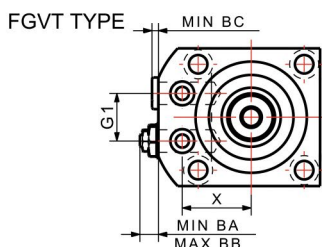
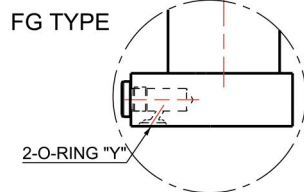
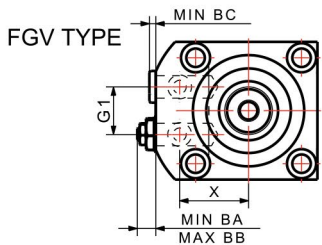

Threaded Body Clamp Introduction

몸통 부위에 나사가 가공되어 있어 위치결정이 용이합니다. 커버를 나사식으로 조립하였기 때문에 씼 교환이 용이하며, 이로 인한 실린더 보수를 쉽게 할 수 있습니다. 내경이 $\varnothing 13 \sim \varnothing 63$ 까지 7종류가 있습니다.

Threaded body clamp has screws processed on the body for easy positioning. The cover is assembled in screw type to facilitate seal exchange. This ensures easy cylinder maintenance. There are seven available piston diameters from $\varnothing 13$ to $\varnothing 63$.

Mounting Method

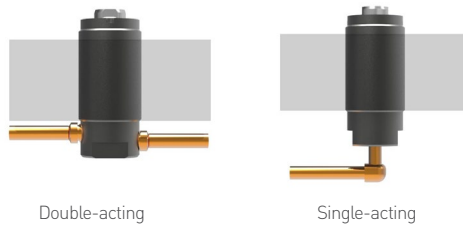

Application



고려사항 Note

사용하는 스트로크는 가급적 표준 실린더 스트로크의 80% 이내에서 사용한다. 또한 로드 부착물 무게가 무거운 경우와 리턴이 빠르고 일정한 속도를 원할 경우는 복동을 선택하고 배관의 이점을 이용시 단동을 선택한다.

The stroke should be preferably used within 80% of the standard cylinder stroke.
If the rod fitting is heavy and fast & constant return speed is required, choose double-acting. If easy piping is required, choose single-acting.

단동 실린더 취급시 주의 사항 Caution for operating single-acting cylinder
단동 실린더 내부에는 인장 스프링이 들어 있어 **로드에 부착물 고정시 로드를 스패너 등으로 잡고 고정한다.** 그렇지 않으면 스프링 또는 볼트가 파손되므로 제품의 사용이 불가능하다. 위의 사항을 따르지 않아 생기는 손상에 대해서는 A/S의 책임을 지지 않는다.

There is a tension spring inside the single-acting cylinder, so be sure to hold the rod with a spanner when fastening the fitting to the rod.
Otherwise, the product may be unusable due to spring or bolt damage.
We are not responsible for product damage caused by failure to comply with the instructions aforementioned.

Model No.

TBD-3225



1 Clamp Type
 TBD = Threaded Body Clamp (Double-acting)
 TBP = Threaded Body Clamp (Single-acting)

2 Piston Diameter
 ex) 32 = $\varnothing 32$

3 Piston Rod Stroke
 ex) 25 = 25mm

Specification

Push/Pull Type

MODEL NO.	Weight (kg)	Max. Clamping Force(kgf)	Effective Area (cm ²)	Oil Capacity (cm ³)	Stroke (mm)	Piston Diameter (mm)	Operating Pressure Range	Operating Temperature Range
TBD-3225	1.2	1,800	7.2	18.1	25	$\varnothing 32$	15~250 kgf/cm ²	0~60°C
TBD-3250	1.4			36.3	50			
TBD-4025	2.1	2,920	11.7	29.5	25	$\varnothing 40$		
TBD-4050	2.6			58.9	50			
TBD-5025	3.0	4,620	18.5	47.1	25	$\varnothing 50$		
TBD-5050	3.6			94.2	50			
TBD-6325	4.1	7,570	30.3	76.0	25	$\varnothing 63$		
TBD-6350	4.8			152.0	50			

Push Type

MODEL NO.	Weight (kg)	Max. Clamping Force(kgf)	Effective Area (cm ²)	Oil Capacity Push (cm ³)	Stroke (mm)	Piston Diameter (mm)	Operating Pressure Range	Operating Temperature Range
TBP-1308	0.11	320	1.30	1.0	8	$\varnothing 13$	15~250 kgf/cm ²	0~60°C
TBP-2015	0.23	780	3.14	4.7	15	$\varnothing 20$		
TBP-2615	0.34	1,320	5.3	8.0	15	$\varnothing 26$		



Threaded Body Clamp Push/Pull Type

Features

1. 몸통의 나사산을 이용하면, 설치가 매우 쉽다.
 2. 보통의 실린더는 몸통의 양쪽 끝에 포트가 있으나 두개의 포트가 모두 한쪽에 있어서 픽스처에 사용하기 쉽다.
 3. 다양한 크기의 제품이 제작된다.
 4. 복동으로 작동되며, 동작의 확실성을 보장한다.
 5. 작동압력 : 15~250kgf/cm²
 6. 피스톤 속도 : 8~100mm/s
 7. 사용온도 : 0~60°C
1. Easy installation with threaded body.
 2. Common cylinders have ports at both ends of the body, but this has two ports on one side and is thus easy to use on fixtures.
 3. Products are manufactured in various sizes.
 4. It performs double-acting and ensure operational accuracy.
 5. Operating Pressure : 15~250kgf/cm²
 6. Piston Speed : 8~100mm/s
 7. Operating Temperature : 0~60°C

Mounting Accessory(Page 117):
MBS4518, MBR4510, MBS6125,
MBR6111, MBS7025, MBR7012,
MBS8025, MBR8015

> TBD - 32 25

① ② ③

① Double-acting ② Piston Diameter(mm) ③ Total stroke(mm)

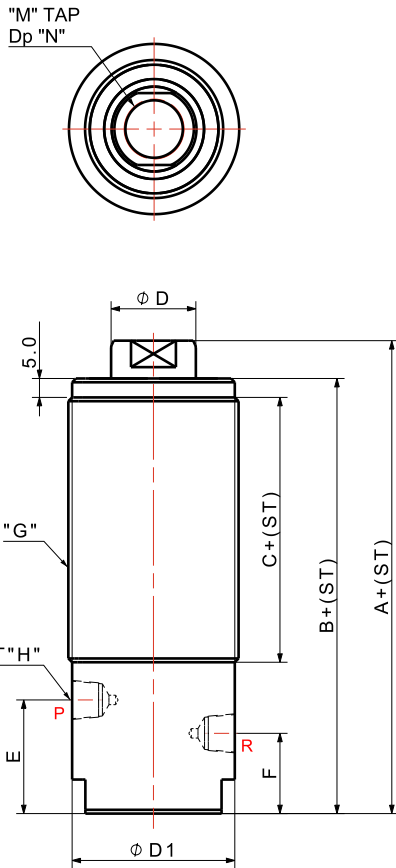

P : Push
R : Pull

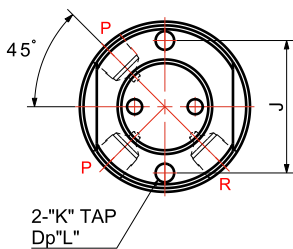

Dimensions

MODEL NO.	TBD-32xx	TBD-40xx	TBD-50xx	TBD-63xx
A	100	100	105	112
B	90	90	97	97
C	45	43	43	45
φD	22.4	30	40	50
φD1	43	57	67	77
E	29	29	29	29
F	22	22	22	22
G	M45x1.5P	M60x2.0P	M70x2.0P	M80x2.0P
H	1/4	1/4	1/4	1/4
J	35	40	48	58
K	M6x1.0P	M8x1.25P	M10x1.5P	M12x1.75P
L	15	15	15	20
M	M16x2.0P	M20x2.5P	M24x3.0P	M30x3.5P
N	15	20	22	25
Piston Dia.	φ32	φ40	φ50	φ63



Threaded Body Clamp Push Type

Features

1. 몸통의 나사산을 이용하면, 설치가 매우 쉽다.
 2. 인장 스프링이 들어있는 것은 피스톤을 함부로 돌리면 고장 원인이 됩니다
 3. 다양한 크기의 제품이 제작된다.
 4. 내부에 스프링이 장착되어 있으므로 장착물 조립시 반드시 피스톤 로드를 공구로 고정시켜야 한다.
 5. 작동압력 : 15~250kgf/cm²
 6. 피스톤 속도 : 8~100mm/s
 7. 사용온도 : 0~60°C
 8. 유로를 가능한 크게 하시오
1. Easy installation with threaded body.
 2. Excessive operation of the product's tension-spring-containing piston is a common cause of malfunction.
 3. Products are manufactured in various sizes.
 4. The piston rod must be fixed with the tool when assembling the fitting due to tension spring inside.
 5. Operating Pressure : 15-250kgf/cm²
 6. Piston Speed : 8-100mm/s
 7. Operating Temperature : 0-60°C
 8. Make piping size as big as possible

Mounting Accessory(Page 117) :
 MBS2112, MBS4518, MBR2110,
 MBR4510, MBS2812, MBS6125,
 MBR2810, MBR6111, MBS3212,
 MBS7025, MBR3210, MBR7012,
 MBS3815, MBS8025, MBR3810,
 MBR8015

> TBP - 13 08

① ② ③

① Single acting ② Piston Diameter(mm) ③ Total stroke(mm)

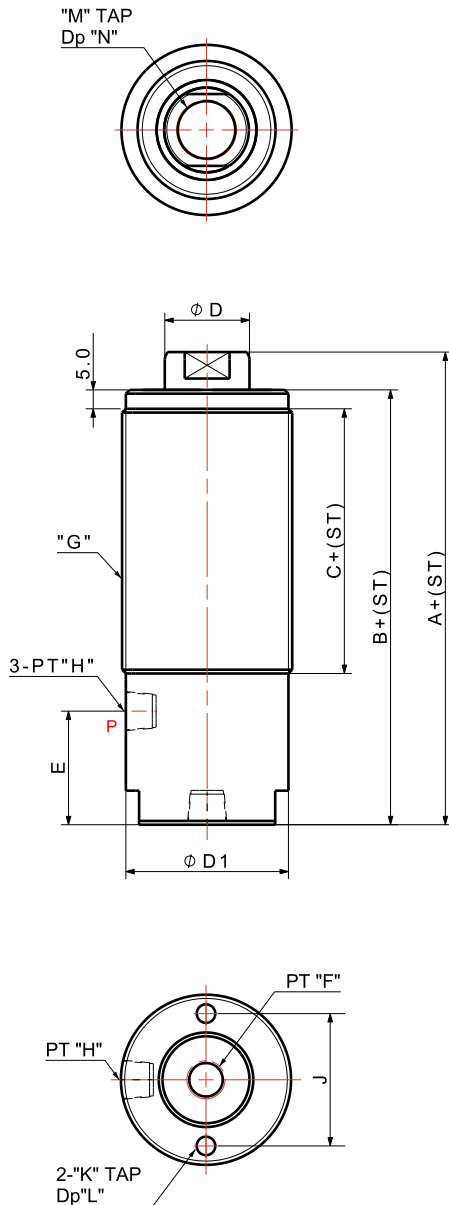

Dimensions

	MODEL NO.	TBP-1308	TBP-2015	TBP-2615
DIMENSIONS (mm)	A	54.5	47	59
	B	46	42	54
	C	36	32	31
	ϕD	7	12	16
	$\phi D1$	18	26	30
	E	-	-	12
	F	1/8	1/8	1/8
	G	M20x1.5P	M28x1.5P	M32x1.5P
	H	-	-	1/8
	J	-	-	-
	K	-	-	-
	L	-	-	-
	M	-	M8x1.25P	M10x1.5P
	N	-	12	17
Piston Dia.	$\phi 13$	$\phi 20$	$\phi 26$	

Hollow Clamp



Features

- | | |
|---|---|
| 1. 단동으로 작동된다. | 1. Pull type. |
| 2. 로드엔 홀이 관통되어 있고 끝 부분에 암나사가 있어 볼트 등을 이용할 수 있다. | 2. There is a hole through the rod so bolts can be used, as there is a female screw at the end. |
| 3. 마운팅 위치에 따라 밀거나 당기는 곳에 이용할 수 있다. | 3. Depending on the mounting position, it can be used for pushing or pulling. |
| 4. 작동압력 : 15~250kgf/cm ² | 4. Operating Pressure : 15~250kgf/cm ² |
| 5. 피스톤 속도 : 8~100mm/s | 5. Piston Speed : 8~100mm/s |
| 6. 사용온도 : 0~60°C | 6. Operating Temperature : 0~60°C |
| 7. 유로는 가능한 크게 하시오. | 7. Make piping size as big as possible. |

Mounting Accessory(Page 117) :
MBS4820, MBS4811, MBS6525,
MBR6512, MBS9025, MBR9016

> HLP - 28 08

① ②

① Piston diameter(mm) ② Total stroke(mm)

Application

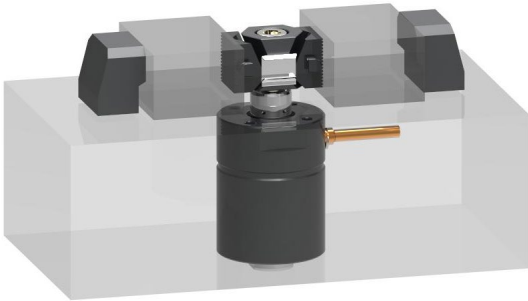

Specification

MODEL NO.	Max. Clamping Force(kgf)	Oil Capacity (cm ³)	Effective Area (cm ²)	Stroke (mm)	Piston Dia. (mm)	Weight (kg)
HLP-2808	1,000	3.31	4.14	8	ø28	0.85
HLP-4012	1,900	9.18	7.65	12	ø40	1.91
HLP-6320	5,300	43.08	21.54	20	ø63	4.28

Dimensions

MODEL NO.	HLP-2808	HLP-4012	HLP-6320
A	86	109	140
B	40	53	70
C	6	9	10
øD	18	28	40
E	12	15	23
F	25	29	34
øG	11	17	21
øH	16	25	35
øJ	48	65	88
K	M48x1.5P	M65 x 1.5P	M88x2.0P
L	M10x1.5P	M12x1.75P	M20x2.5P
M	15	20	32
N	M6x1.0P	M8x1.25P	M12x1.75P
P	10	16	18
Q	1/8	1/4	3/8
R	37	50	70

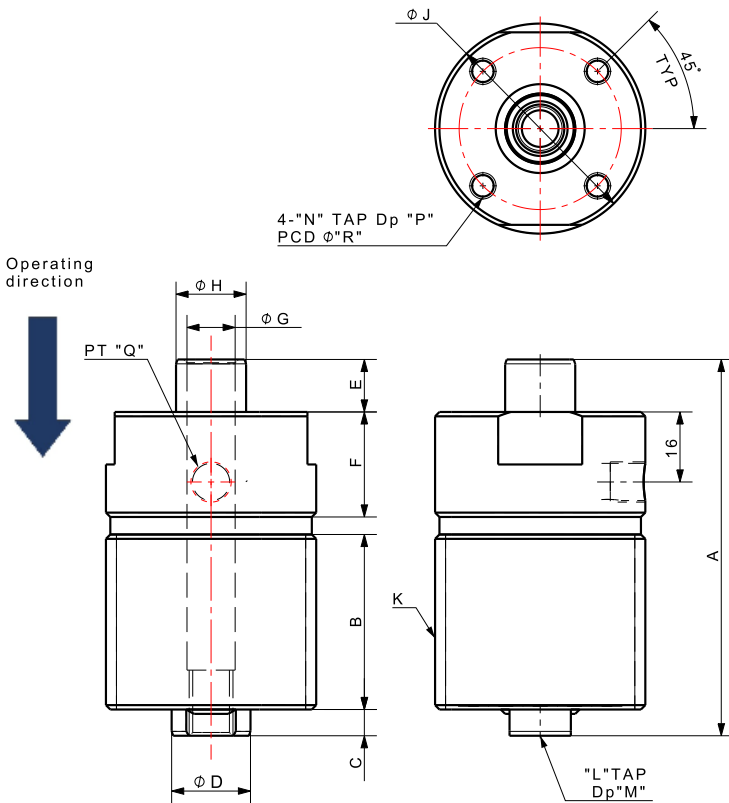

Edge Clamp



Features

- | | |
|--|--|
| 1. 페이스 커터로 공작물의 상면을 가공할 때 공작물의 측면을 공구간섭 없이 클램프 할 수 있다. | 1. When processing the upper surface of the workpiece with a face cutter, you can clamp the side of the workpiece with the edge clamp without tool interference. |
| 2. 제품이 컴팩트하다. | 2. Compact size |
| 3. 단동으로 작동된다. | 3. Single-acting |
| 4. 수직 클램핑력은 수평 클램핑력의 약 1/3이 작용한다. | 4. The vertical clamping force is approximately 1/3 of the horizontal clamping force. |
| 5. 작동압력 : 15~250kgf/cm ² | 5. Operating Pressure : 15~250kgf/cm ² |
| 6. 사용온도 : 0~60°C | 6. Operating Temperature : 0~60°C |

> EDG - 25 10
① ②

① Piston diameter(mm) ② Total stroke(mm)

Application

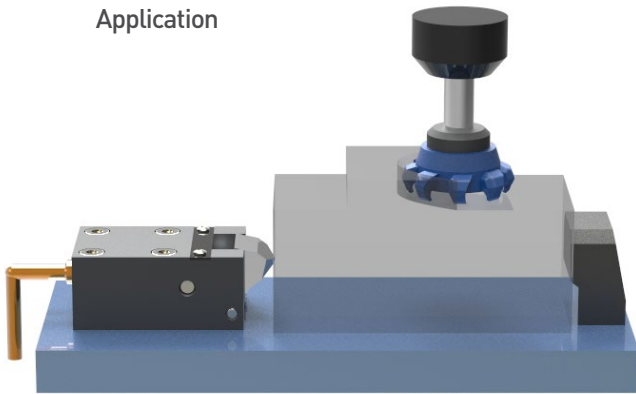

Clamping Force

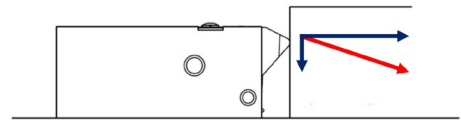

Specification

MODEL NO.	Max Clamping Force(kgf)	Oil Capacity(cm ³)	Effective Area(cm ²)	Stroke(mm)	Piston Diameter (mm)	Weight (kg)
EDG-2510	1,220	4.9	4.9	10.0	ø25.0	1.41
EDG-3610	2,543	10.0	10.0	10.0	ø36.0	2.50

(주문제작)

Dimensions

MODEL NO.	EDG-2510	EDG-3610
A	40	56
B	10	12
C	90	96
D	40	50
E	23	27
F	60	80
G	30	40
H	34.4	42.2
I	9	11
J	14	18
K	9	11

Drawing

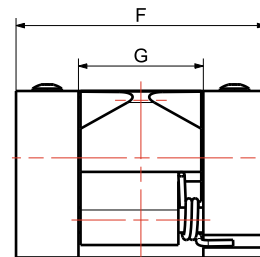
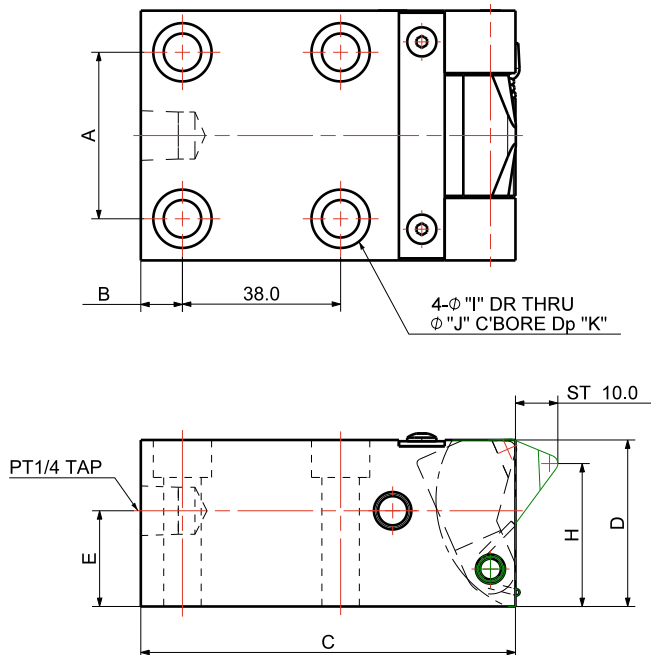



Rocker Clamp

Features

1. 신속 금형 교환용(Quick Die Change)클램프로 적합하며 특히 프레스 금형의 교환에 편리하도록 제작되어 있다.
2. 표준 공작물의 고정용으로 쉽게 응용하여 적용할 수 있다.
3. 로커 암의 작동 스트로크가 짧아 금형의 베이스 플레이트 사이의 공간이 협소하여 제약을 받는곳에 쉽게 적용할 수 있다.
4. 피봇핀으로 연결 구성되어 있어 견고하고 안전하게 사용할 수 있다.
5. 단동으로 작동된다.
6. 작동압력 : 15~250kgf/cm²
7. 사용온도 : 0~60°C

Application

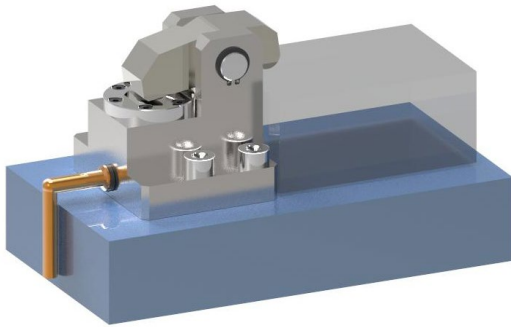

1. This product is suitable for Quick Die Change clamps, and it is made for convenient press die replacement.
2. It can be applied easily for fixing standard workpiece.
3. The short operating stroke of the rocker lever is suitable for a constrained space between the base plates of die.
4. It is connected to the pivot pin and can be used firmly and safely.
5. It performs in single-acting.
6. Operating Pressure : 15~250kgf/cm²
7. Operating Temperature : 0~60°C

Specification

MODEL NO.	Operating Stroke(mm)	Oil Capacity (cm ³)	Effective Area (cm ²)	Max. Clamping Force(kgf)	Weight (kg)
RCS-3005	5.0	3.5	7.0	1,900	2.2

- > RCS - 30 05
- ① Piston diameter(mm)
② Total stroke(mm)

> RCS - 3005

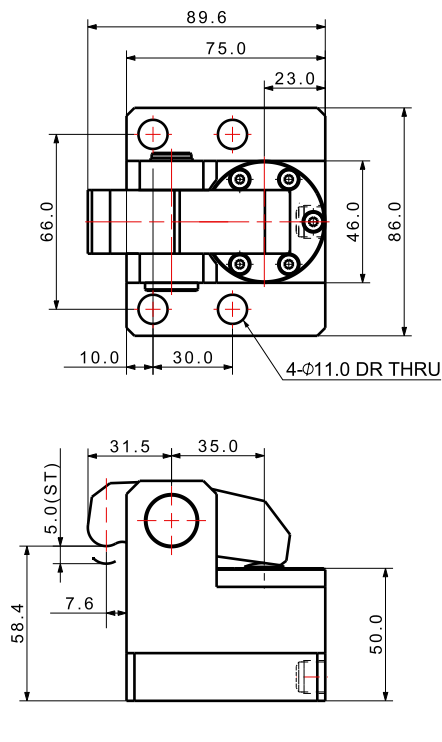

Rocker Clamp



Features

1. 신속 금형 교환용(Quick Die Change)클램프로 적합하며 특히 프레스 금형의 교환에 편리하도록 제작되어 있다.
2. 표준 공작물의 고정용으로 쉽게 응용하여 적용할 수 있다.
3. 로커 암의 작동 스트로크가 짧아 금형의 베이스 플레이트 사이의 공간이 협소하여 제약을 받는곳에 쉽게 적용할 수 있다.
4. 손에 의해 클램프 암을 원하는 방향으로 회전시킬수 있어 금형의 장탈착이 용이하도록 되어있다.
5. 피봇핀으로 연결 구성되어 있어 견고하고 안전하게 사용할 수 있다.
6. 단동으로 작동된다.
7. 밑면의 암나사와 표준 T-슬롯너트 등을 이용하여 설치할 수 있으며 마운팅 구멍 높이에 따른 스페이스를 이용하여 클램핑 높이를 다양하게 조절할 수 있다.
8. 작동압력 : 15~250kgf/cm²
9. 사용온도 : 0~60°C

Application

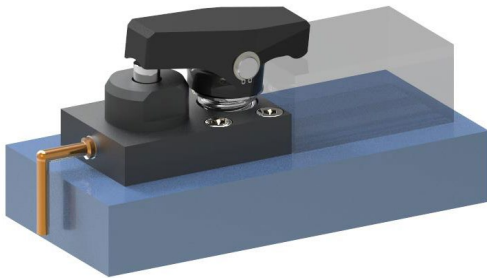

1. This product is suitable for Quick Die Change clamps, and it is made for convenient press die replacement.
2. It can be applied easily for fixing standard workpiece.
3. The short operating stroke of the rocker lever is suitable for a constrained space between the base plates of die.
4. The clamp lever can be rotated to the desired direction, making it easy to attach/detach the mold.
5. It is connected to the pivot pin and can be used firmly and safely.
6. It performs in single-acting.
7. It can be installed using a female thread on the bottom and a standard T-slot nut, and the clamping height can be adjusted by the space according to the mounting hole height.
8. Operating Pressure : 15~250kgf/cm²
9. Operating Temperature : 0~60°C

Specification

MODEL NO.	Operating Stroke(mm)	Oil Capacity (cm ³)	Effective Area (cm ²)	Max. Clamping Force(kgff)	Weight (kg)
RCS-3006	6.0	4.2	7.0	2,400	2.6

- > **RCS - 30 06** ① Piston diameter(mm)
 ① ② ② Total stroke(mm)

> RCS - 3006

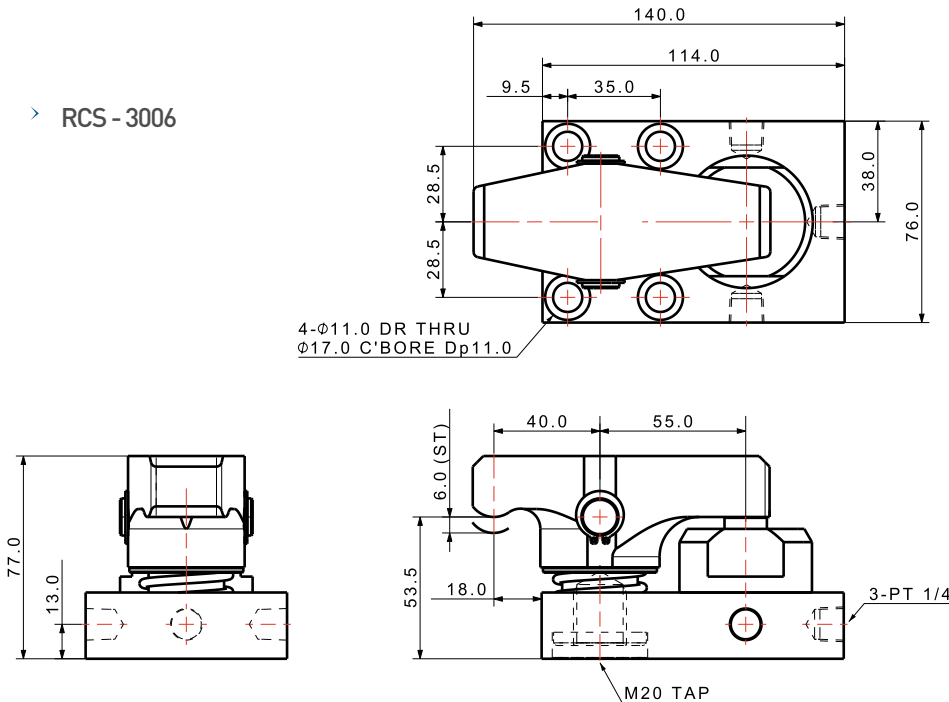

Vise Clamp Applications

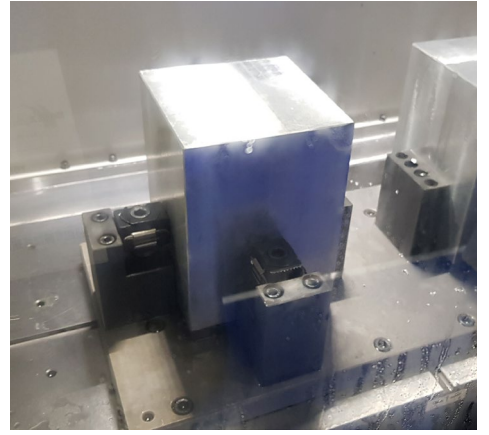
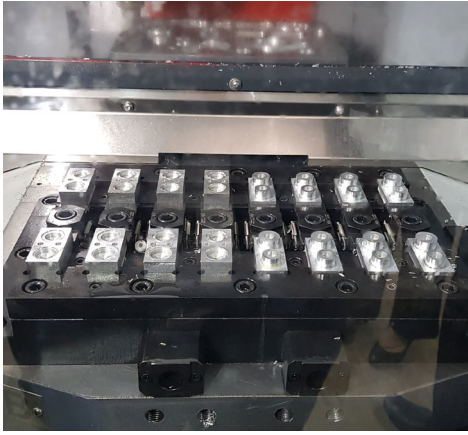

Vise Clamp Types

Small Size



Knurling Type



Flat Type

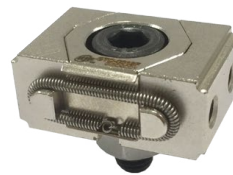

Tap Type

Standard Size



Small Pitch Knurling Type



Big Pitch Knurling Type



Tap Type 1



Tap Type 2

Vise Clamp Introduction

1. 뿔이 아래로 움직일 때 양쪽의 테이퍼가 옆과 아래로 밀려나면서 공작물을 클램프합니다.
2. 제한된 공간에 다량의 공작물을 가공하는 지그제작에 유리합니다.
3. 수동이든 자동이든 관계없이 모두 적용 가능합니다.

1. As the wedge moves downwards, the tapers on both sides are pushed to the side and down to clamp the workpiece.
2. It is advantageous for a jig that processes a large workpiece in a limited space.
3. The product is applicable to manual and automatic operation environment.

Movement Distance

A ≠ B : 클램프 가능
A = B : Possible to clamp

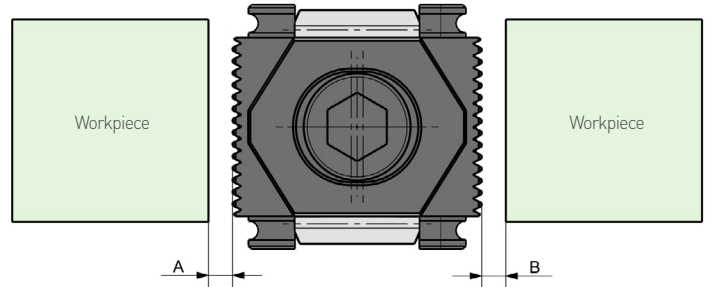

Operation

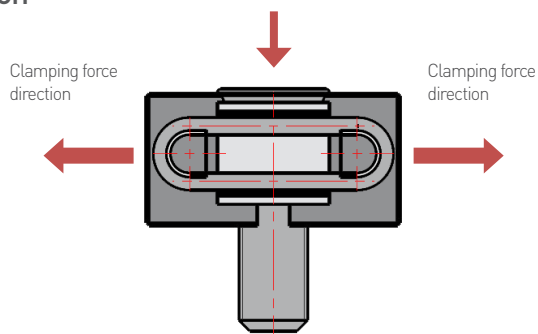

STC-0812

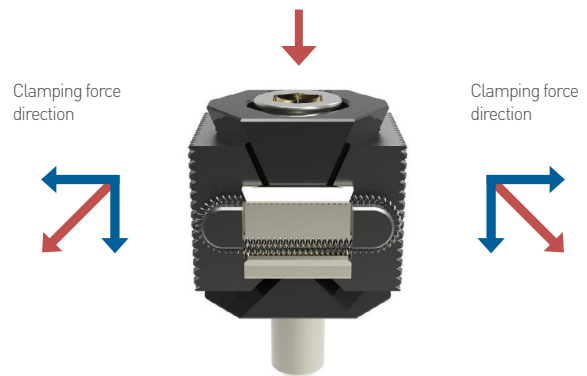

STC-1223

Application

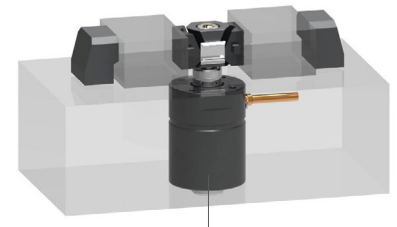
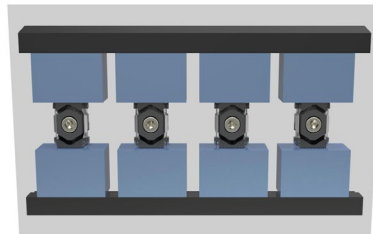
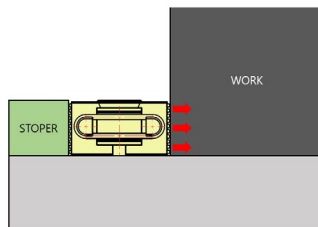

Hollow Clamp

Specification

MODEL NO.	Pad Type	Pad Movement (mm)	Pad Width (mm)	Bolt Size	Clamping Force (max.kgf)	Tightening Torque (Max. kgf.cm)	Weight (kg)
STC-0812	Knurling	1.0	21.2	M8 x 1.25P	2,494	414	0.08
STC-0812P	Flat	1.0	21.2	M8 x 1.25P	2,494	414	0.08
STC-0812F	Tap	1.1	21.2	M8 x 1.25P	2,494	414	0.09
STC-1223	Knurling	3.5	30	M12 x 1.75P	9,071	1,520	0.38
STC-1223M	Knurling	3.5	30	M12 x 1.75P	9,071	1,520	0.38
STC-1223B	Tap	3.5	30	M12 x 1.75P	9,071	1,520	0.37
STC-1223F	Tap	3.5	27	M12 x 1.75P	9,071	1,520	0.35

> STC-0812

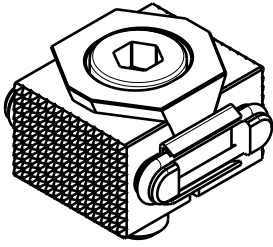

Knurling Type

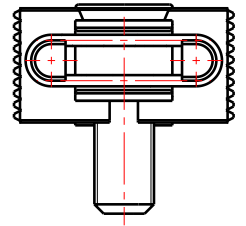
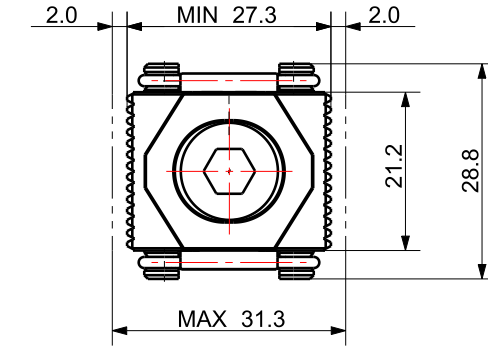

Clamping State

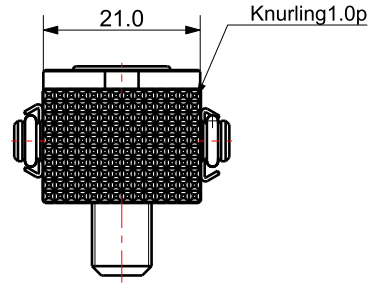
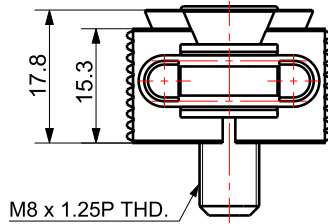

> STC-0812P

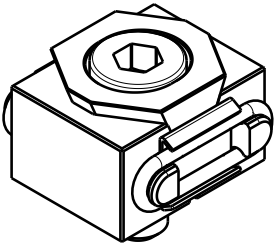

Flate Type

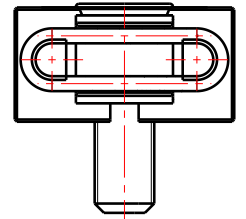
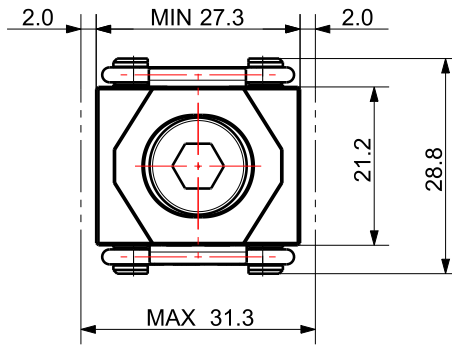

Clamping State

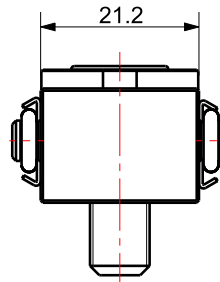
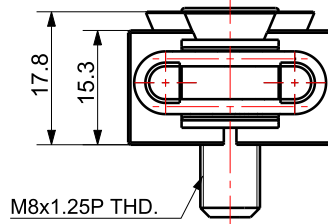

> STC-0812F

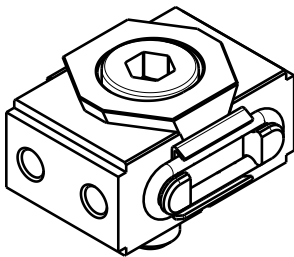

Tap Type

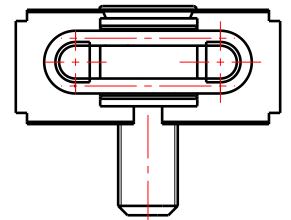
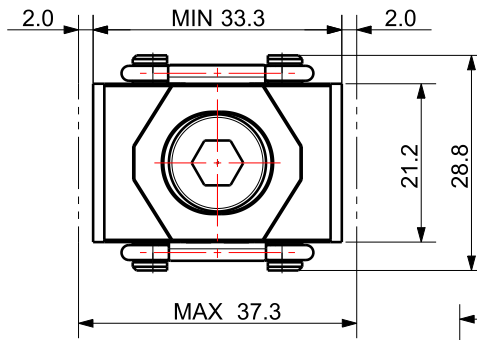

Clamping State

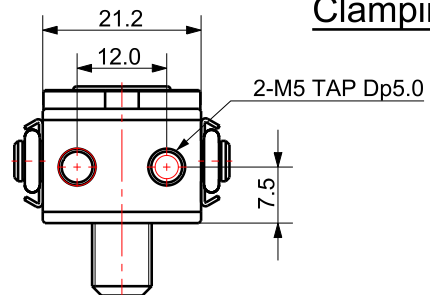
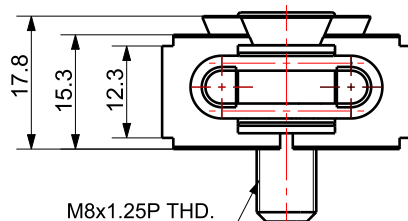

> STC - 1223

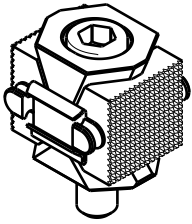

Small Pitch
Knurling Type

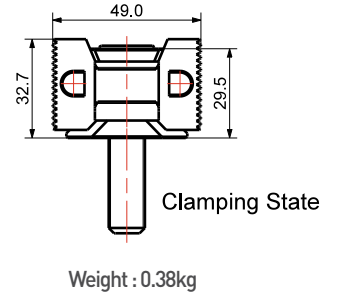
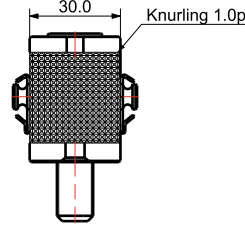
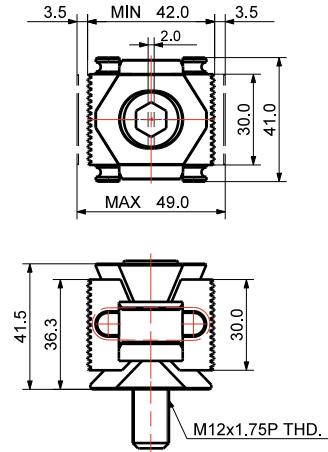

> STC - 1223M

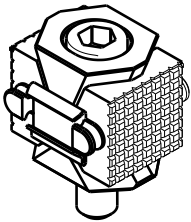

Big Pitch
Knurling Type

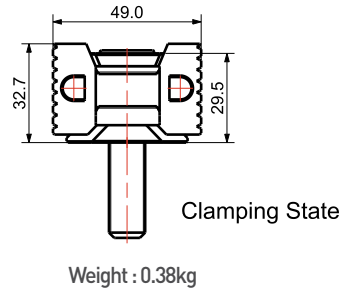
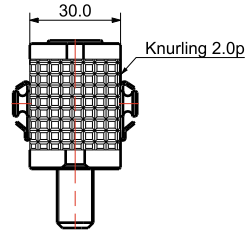
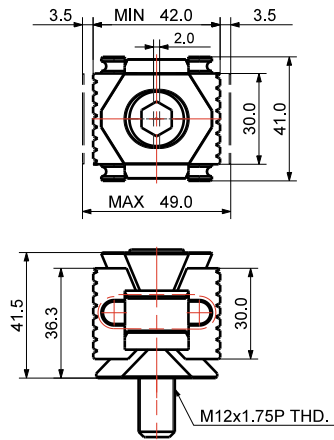

> STC - 1223B

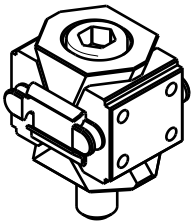

Tap Type 1

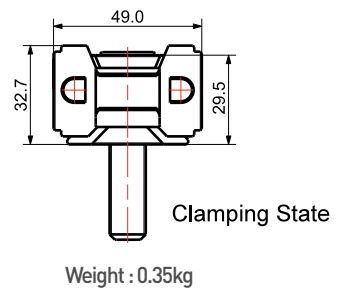
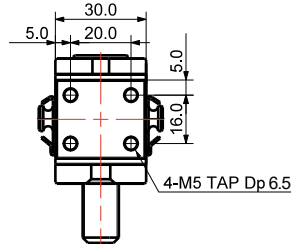
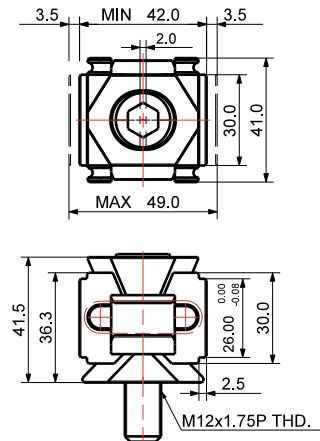

> STC - 1223F

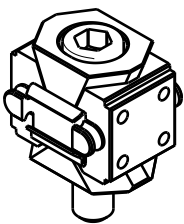

Tap Type 2

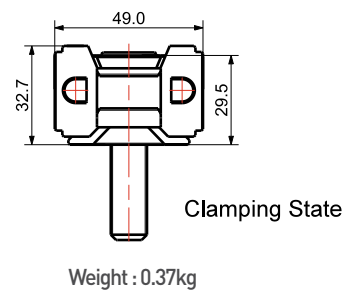
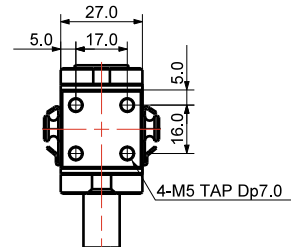
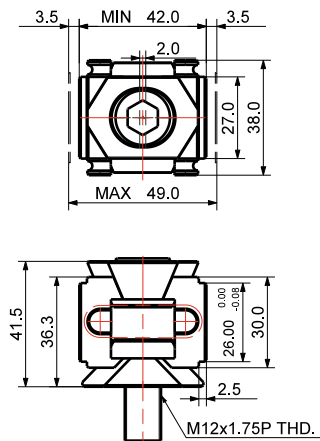

Auto Coupler Threaded Type

유체회로 연결을 위한 자동 커플러 Coupler for connecting fluid circuit

사용가능 유체: 유압용, 오일/물 겸용!! Available fluids: Hydraulic, Oil/Water!!

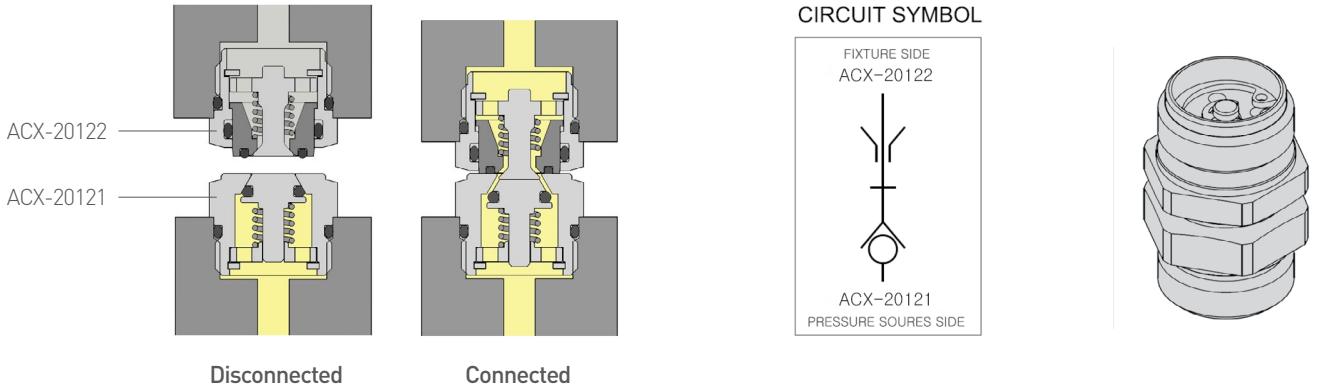

Model No.

ACX-20121



1 Fluid
ACX = Pneumatic & Hydraulic

2 Body Diameter
ex) 20 = M20

3 Side Type
1 = Pressrue Source Side
2 = Fixture side

Specification

MODEL NO.	Weight	Max. Operating Pressure(kgf)	Operating Temperature	Coupling Stroke	Max. Reaction Force	Max. Area	Tightening Torque	Flow Rate
ACX-20121	33g	70kgf/cm ²	0~70°C	1.5mm	112kgf@70kgf/cm ²	12.6mm ²	250kgf.cm	16L/min@70kgf/cm ²
ACX-20122	34g							

NEW



ACX-20121
(압력공급부)



ACX-20122
(지그부)

Auto Coupler Threaded Type

Features

1. 유압용, 물 가능
 2. 유체회로 연결을 위한 커플러
 3. 자동화에 알맞은 컴팩트 사이즈
 4. 반동력: 112kgf@70kgf/cm²
 5. 사용압력: Max. 70kgf/cm²
1. Hydraulic, Water capable
 2. Coupler for connecting fluid circuit
 3. Compact and suitable for automatic
 4. Reaction Force: 112kgf@70kgf/cm²
 5. Operating Press.: Max. 70kgf/cm²

> ACX-20121

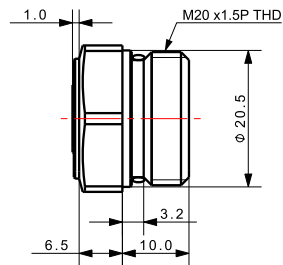
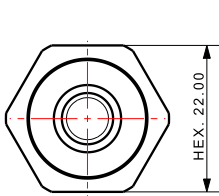

CIRCUIT SYMBOL

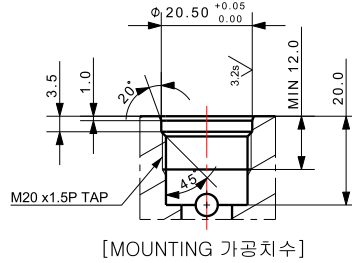
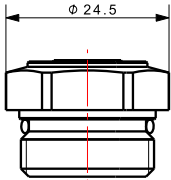
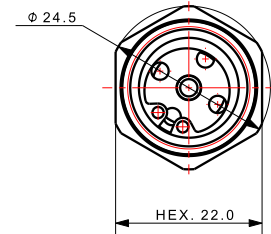
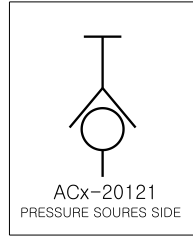

[MOUNTING 가공치수]

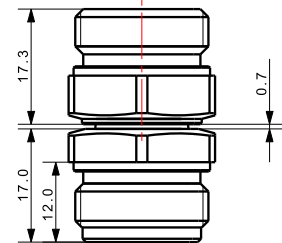

편심량: +/-0.5mm
각도공차: 0.3도

CIRCUIT SYMBOL

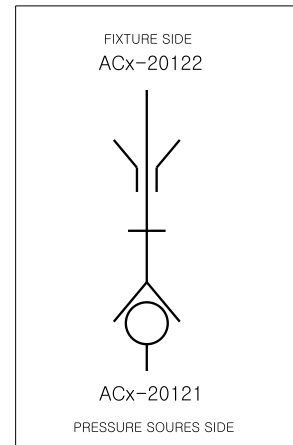

> ACX-20122

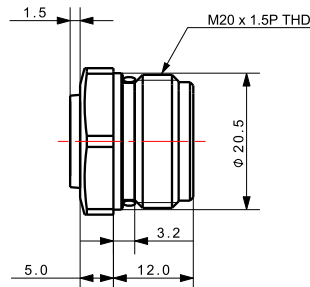
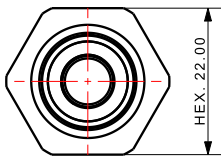

CIRCUIT SYMBOL

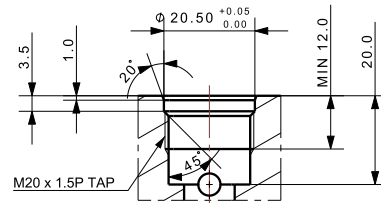
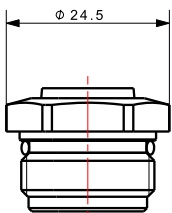
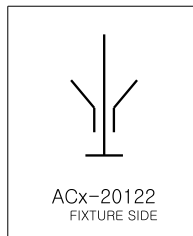

[MOUNTING 가공치수]

Auto Coupler Threaded Type

유체회로 연결을 위한 자동 커플러
Coupler for connecting fluid circuit

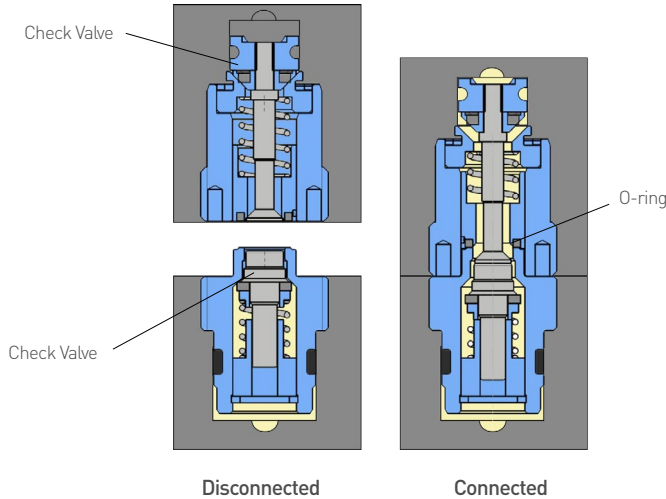

Operating conditions

1. 커플러들이 연결되기 전 같은 중심축에 있어야 한다.
 2. 연결되기 약 3mm전에 편심공차 내에서 가이드되어야 한다.
 3. 커플러 표면의 씰부분은 오염으로부터 보호되어야 한다.
 4. 마운팅 표면의 품질은 도면을 참고.
- * 압력이 공급되는 상태에서 커플러들을 연결 혹은 분리하지 마십시오.

1. Both couplers must be on the same central axis before connected.
 2. They must be guided about 3mm in the eccentric tolerance before connected.
 3. Seal areas on the coupler surface must be protected from contamination.
 4. Refer to drawing for the mounting surface quality.
- * Do not disconnect or connect couplers when pressure is provided.

Model No.

ACO-2001

ACO - 20 - 01

1 - 2 - 3

1 Fluid
ACO = Oil (Hydraulic)

2 Body Diameter
ex) 20 = M20

3 Side Type
01 = Pressure Source Side
02 = Fixture Side

Specification

MODEL NO.	Threaded Body Size	Max. Operating Pressure (kgf/cm ²)	Operating Temperature	Usable Fluid	Coupling Stroke(mm)	Max. Reaction Force(kgf)	Flow max. /minute	Radial Positioning Tolerance(mm)	Permitted Angle Tolerance	Weight (g)
ACO-2001	M20 x 1.5P	350	0~70°C	Oil/Air	4.3	335	8L	±0.3	±1°	30
ACO-2002										40
ACO-2401	M24 x 1.5P	500				785	12L			65
ACO-2402										50

★ 주의사항 Caution

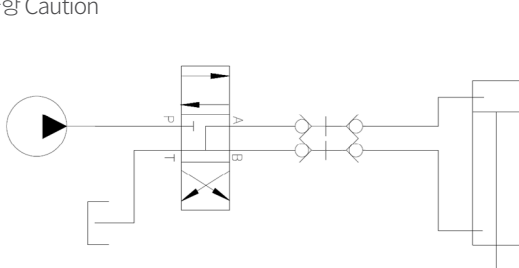

솔레노이드밸브는 3 포지션/4 웨이를 사용하십시오. 연결/분리시 중앙에 위치하여 유압공급을 정지시키십시오.

Use a 3 positions/4 ways solenoid valve. When connecting or dis-connecting couplers, place it in the center to stop hydraulic pressure.

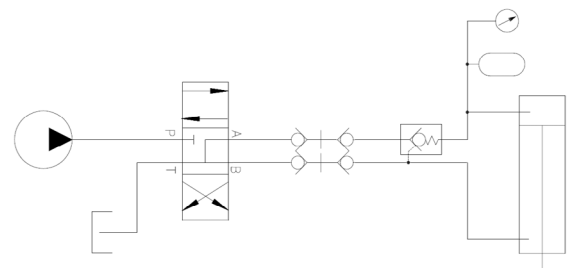

픽스처를 분리 후 작업할 경우는 위의 회로도를 참고하십시오.

When dis-connecting and working the fixture, please refer to the circuit diagram on the left.

이런 종류의 솔레노이드밸브는 사용하지 마십시오.
Do not use the solenoid valve on the left

조립 시 적절한 도구로 오토커플러에 있는 홈을 이용해 돌리십시오.
When assembling, use an appropriate tool to turn through the hole in the autocoupler.

> ACO-□02

> ACO-□01

Auto Coupler Threaded Type

Features

- | | |
|---------------------|---|
| 1. 스테인레스 재질 | 1. Stainless Material |
| 2. 유체회로 연결을 위한 커플러 | 2. Coupler for connecting fluid circuit |
| 3. 자동화에 알맞은 컴팩트 사이즈 | 3. Compact and suitable for automatic |
| 4. 진공용으로 사용 가능 | 4. Can be used for vacuum |



> ACO-□02

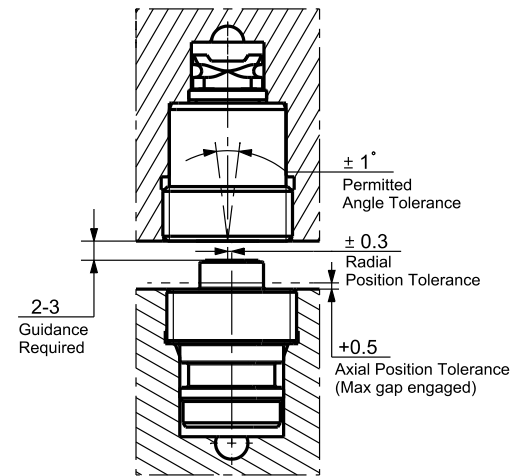
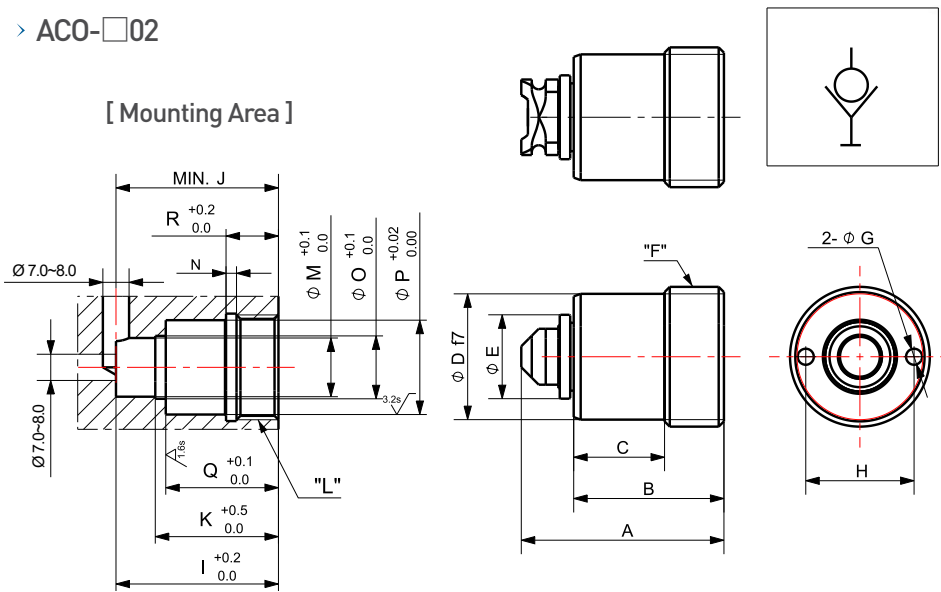

> ACO-□01

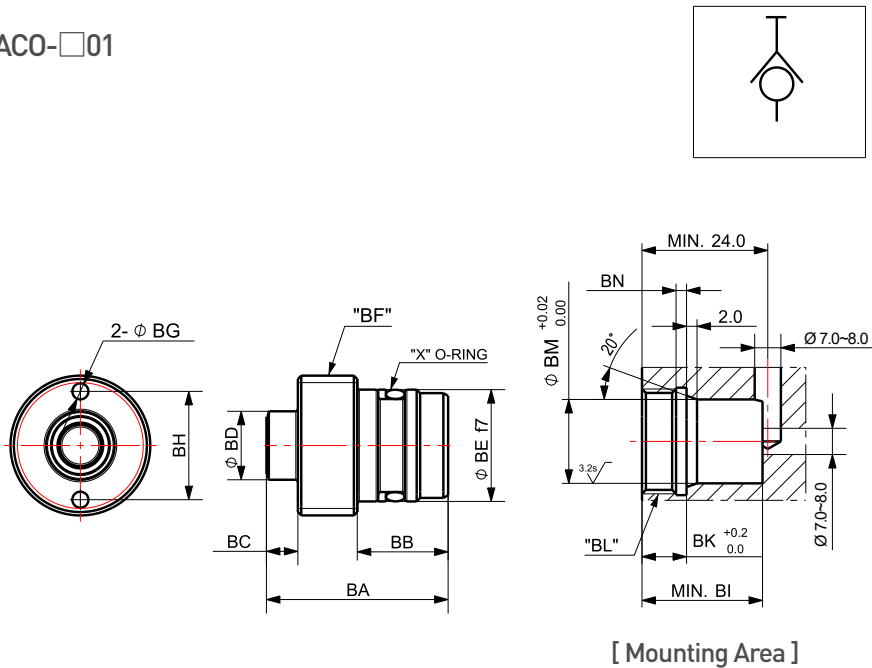

CIRCUIT SYMBOL

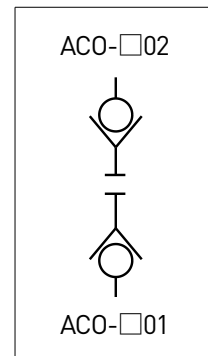

Dimensions

MODEL	A	B	C	D	E	F	G	H	I	J	K	L	M	N	O	P	Q	R	X	BA	BB	BC	BD	BE	BF	BG	BH	BI	BJ	BK	BL	BM	BN
ACO-20□	29.0	21.5	13.0	18.0	12.0	M20 x1.5P (Dp4.0)	2.3	15.5	31.0	31.0	23.5	M20 x1.5P	11.2	2.0/ Ø20.5	12.0	18.0	21.5	10.0	AS568 -014	26.0	13.0	4.5	9.8	16.0	M20 x1.5P (Dp4.0)	2.3	15.5	23.0	24.0	8.5	M20 x1.5P	16.0	2.0/ Ø20.5
ACO-24□	29.0	21.5	13.4	20.5	12.0	M24 x1.5P (Dp5.0)	2.8	18.5	31.0	31.0	23.5	M24 x1.5P	11.2	2.0/ Ø24.5	14.0	20.5	21.5	10.0	AS568 -018	31.0	18.0	4.5	13.3	21.9	M24 x1.5P (Dp5.0)	2.8	18.5	26.5	26.0	8.5	M24 x1.5P	22.0	2.0/ Ø24.5

Auto Coupler Flange Type

유체회로 연결을 위한 자동 커플러 Coupler for connecting fluid circuit

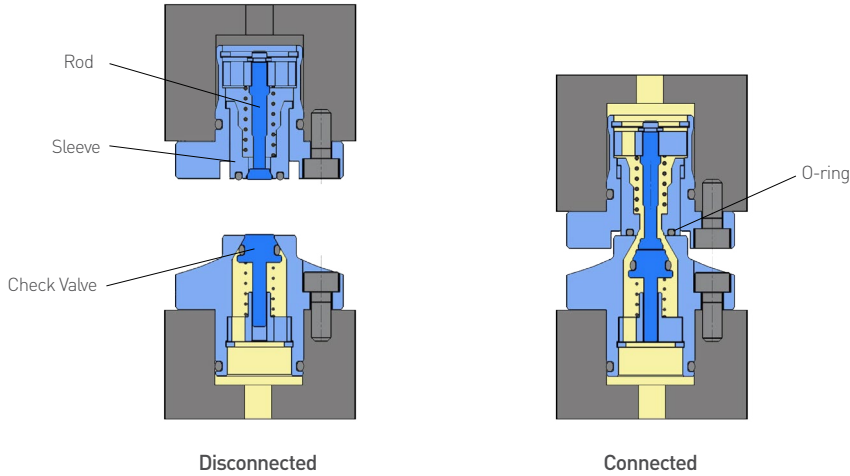

1. 상측과 하측이 분리상태일 때, 체크밸브에 의해 유압공급측 유체 자동 차단.
 2. 상측과 하측이 연결상태일 때, 슬리브가 후퇴하며 로드가 체크밸브를 밀며 개방 됨.
- * 압력이 공급되고 있을 때 오토커플러를 분리 및 연결하지 마십시오.

1. When the upper and lower side are disconnected, fluid is shut off automatically.
 2. When the upper and lower side are connected, the sleeve is moved back and the rod pushes the check valve to open.
- * Do not disconnect or connect auto coupler when pressure is provided.

Model No.

ACO-1801F

ACO	-	18	01	F
1		2	3	4

1 Fluid
ACO=Oil (Hydraulic)

2 Body Diameter
ex) 18=ø18

3 Side Type
01 = Pressure Source Side
02 = Fixture Side

4 Body Type
F=Flange

Specification

MODEL NO.	Flow Rate	Max. Operating Pressure(kgf)	Operating Temperature	Coupling Stroke(mm)	Usable Fluid	Weight (g)
ACO-1801	24L/min @30kgf/cm ²	250	0~70°C	3	Oil	71
ACO-1802						65

★ 주의사항 Caution

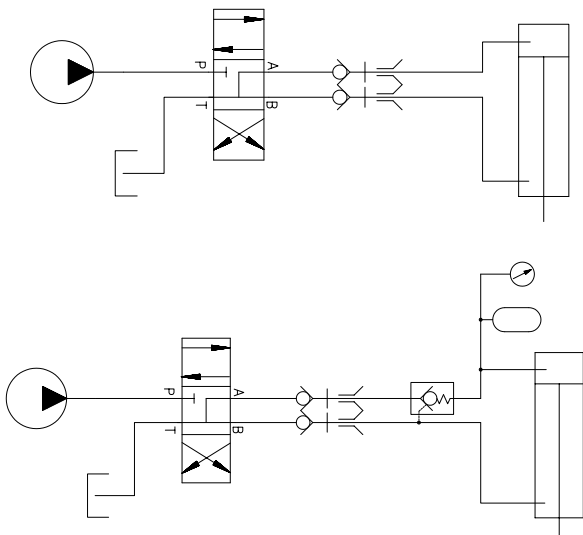

솔레노이드밸브는 3 포지션/4 웨이를 사용하십시오. 연결/분리시 중앙에 위치하여 유압공급을 정지시키십시오.

Use a 3 positions/4 ways solenoid valve. When connecting or dis-connecting couplers, place it in the center to stop hydraulic pressure.

이런 종류의 솔밸브는 사용하지 마십시오.
Do not use the solenoid valve on the left

픽스처를 분리 후 작업할 경우는 좌측 회로도를 참고하십시오.

When dis-connecting and working the fixture, please refer to the circuit diagram on the left.

> ACO-1801F

> ACO-1802F



Auto Coupler Flange Type

Features

1. 작동압력범위 : 250kgf/cm² 이하
 2. 유체회로 연결을 위한 커플러
 3. 자동화에 알맞은 컴팩트 사이즈
 4. 반동력: 291kgf at 250kgf/cm²
 5. 유압용
1. Operating Pressure Range : lower than 250kgf/cm²
 2. Coupler for connecting fluid circuit
 3. Compact and suitable for automatic
 4. Reaction Force: 291kgf at 250kgf/cm²
 5. For Hydraulic

주의: ACO-1801F를 유압이 공급되는 면에 설치하십시오.

Note: Install ACO-1801F on the hydraulic providing side.

>ACO-1802F

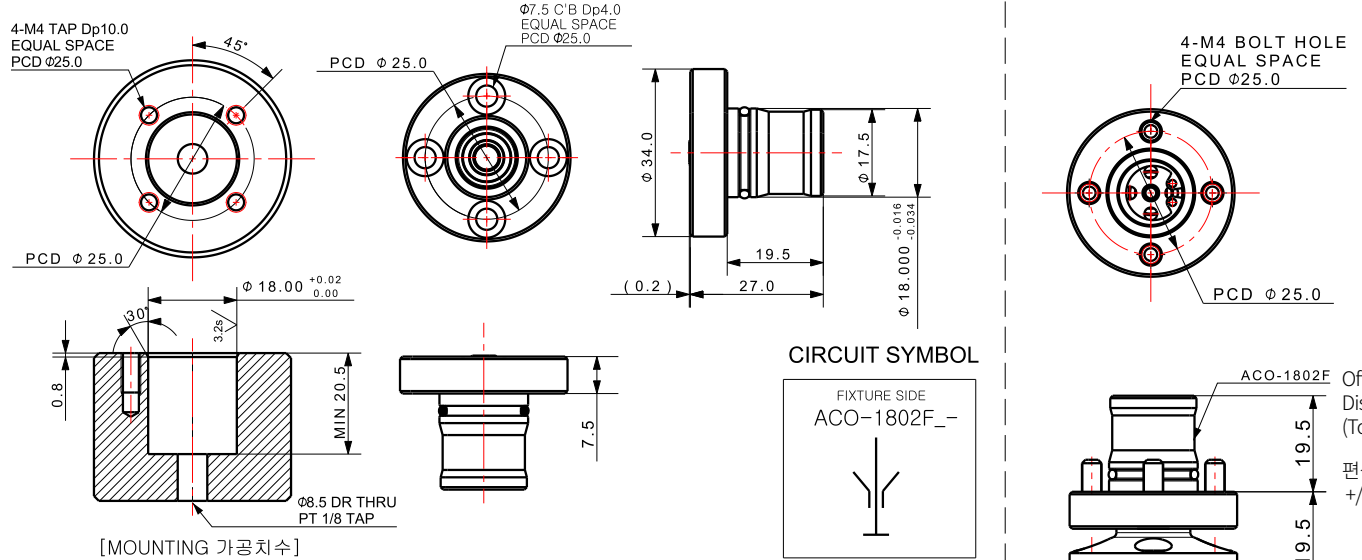

>ACO-1801F

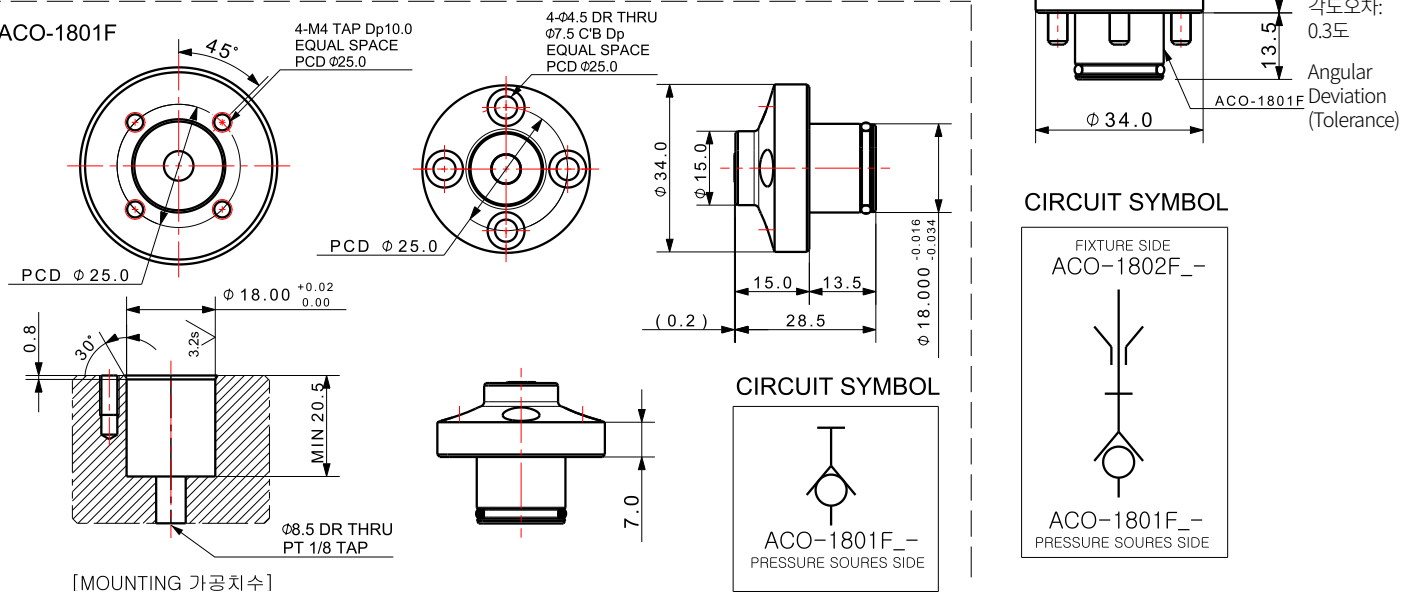

Rotary Joint Applications

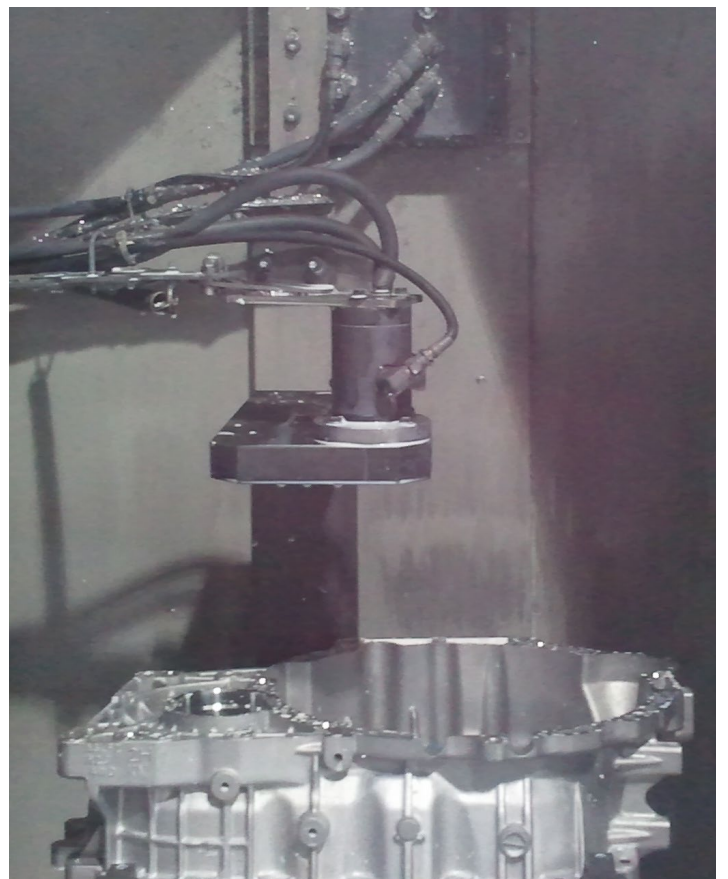
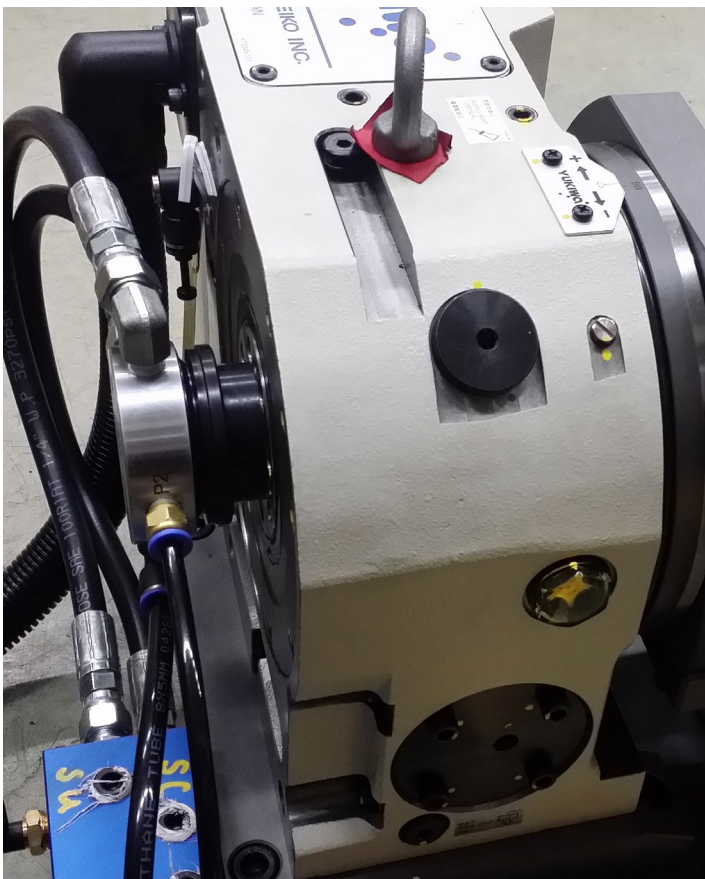
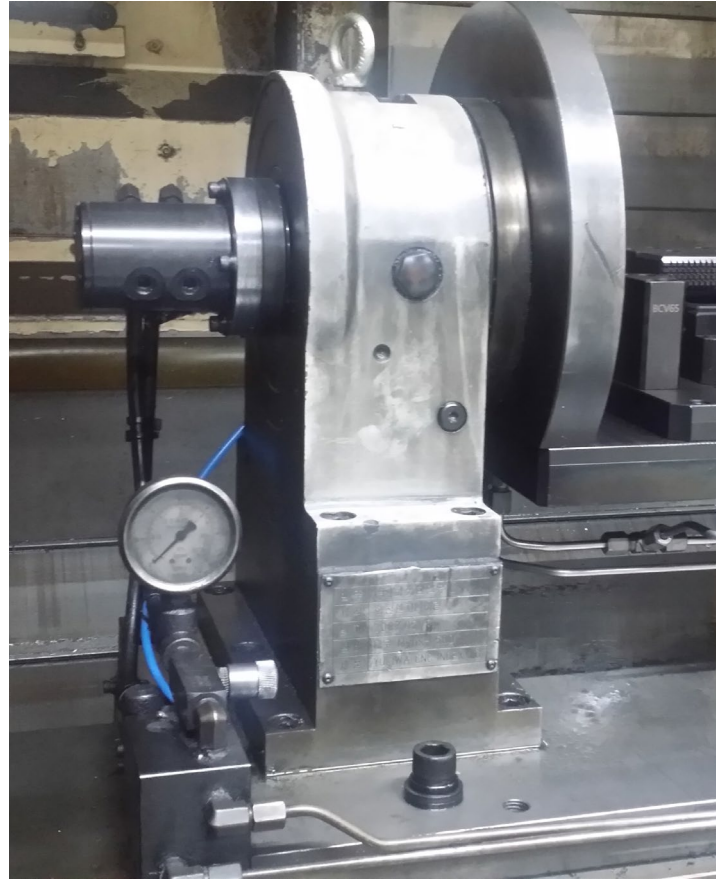
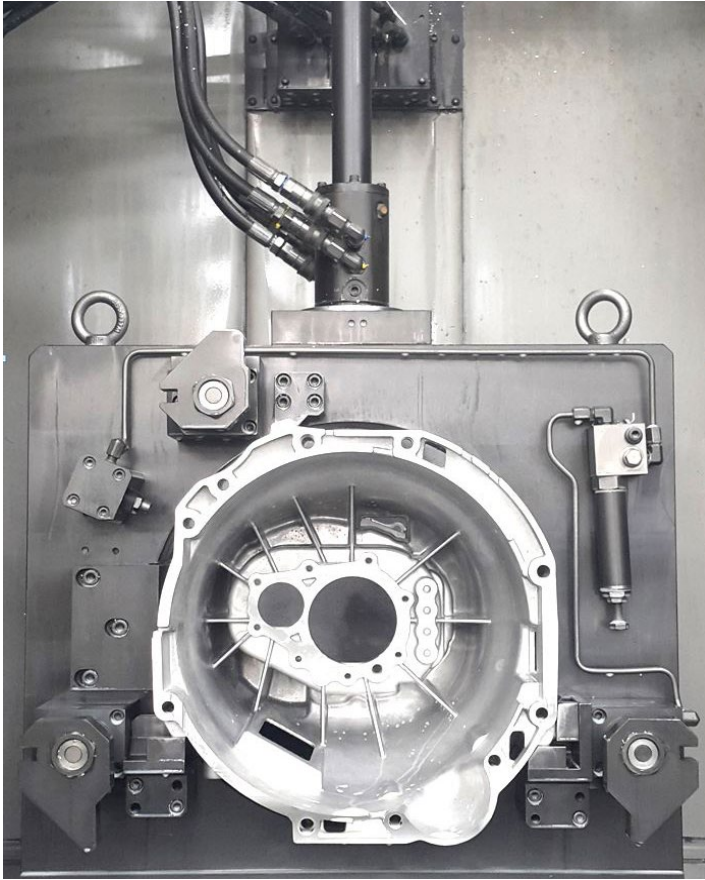

Rotary Joint Introduction

로터리 조인트는 설비 혹은 기기에서 회전체에 유압, 공압, 절삭유를 공급할 때 사용되어집니다.
 (주케이제이에프는 다양한 형태의 로터리 조인트를 보유하고 있으며 사용 조건에 맞는 최상의 선택이 가능합니다.)



Rotary joint is used to supply hydraulic, pneumatic, cutting oil or vacuum to a rotor in equipment or facilities.
 KJF has various types of rotary joint to suit various usage conditions.

Structure

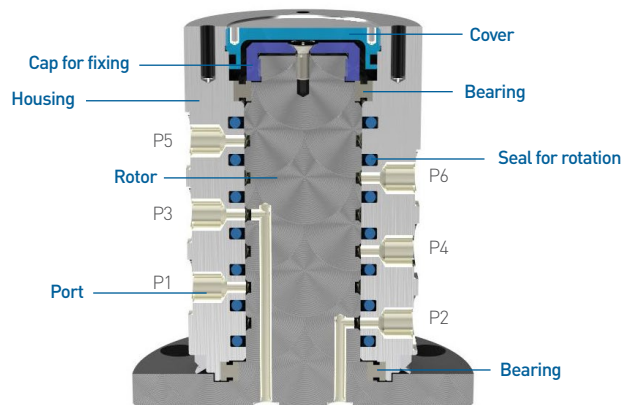

Rotary Joint Type



Flange type



Cartridge type



Compact Flange type



Top type



Male type

Rotary Joint Flange Type



Features

1. 정지된 유압 공급 라인에서 회전하는 유압 부품에 유압을 공급한다.
2. 배관의 꼬임을 방지한다.
1. Rotary joint supply hydraulic to rotating hydraulic components in the stopped hydraulic supply line.
2. It prevents piping twisting.

Specifications

- | | |
|--|---|
| 1. 최대 공압 사용압력 : 9.9kgf/cm ² | 1. Max. pneumatic operating pressure : 9.9kgf/cm ² |
| 2. 최대 유압 사용압력 : 150kgf/cm ² | 2. Max. hydraulic operating pressure : 150kgf/cm ² |
| 3. 사용온도범위 : 0~70°C | 3. Operating temperature range : 0~70°C |
| 4. 최대 허용 회전수 : 120 rpm | 4. Max. RPM : 120rpm |
| 5. 씰 재질 : 전용씰 | 5. Sealing material : Exclusive seal |
| 6. 사용유체 : 기계 작동유, air, 절삭유 | 6. Fluid : hydraulic, air, cutting oil |

Structure

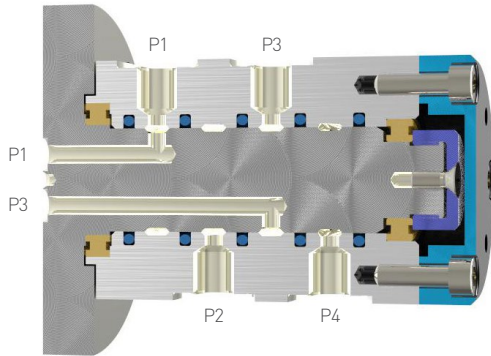

플랜지 타입 로터리 조인트는 탭핑 센터 & 수직 머시닝 센터의 인덱스 픽스처와 수평 머시닝 센터의 픽스처에 사용하면 편리합니다.

Flange type is convenient to use for index fixture of tapping center & vertical machining center and fixture of horizontal machining center.

Application

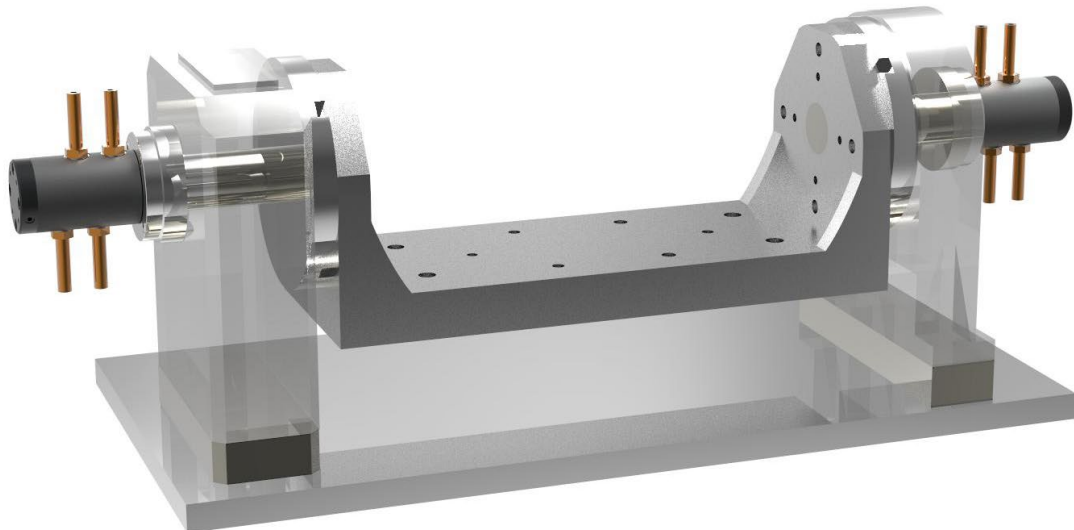

Rotary Joint Flange Type

MODEL NO	RTC-1114G	RTC-3030G
Number of Lines	2	3
Fluid	Hydraulic Oil, Air, Cutting Fluid	
Max. Operating Pressure	150kgf/cm ²	
Max. Revolutions per Minute	120rpm	
Operating Temperature Range	0~70°C	
Weight	3.1 kg	3.1 kg

> RTC - 1114G

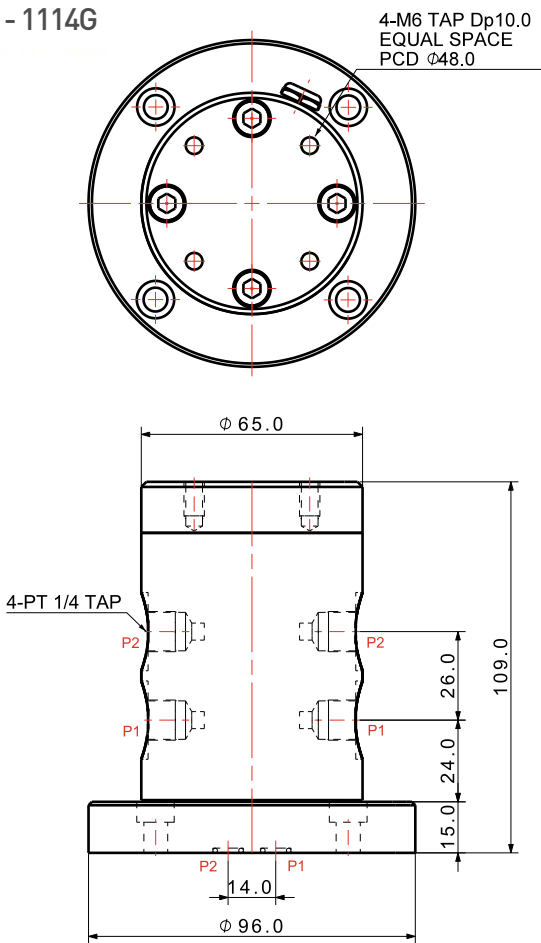

4-φ7.0 DR THRU
φ11.0 C,B Dp6.0
EQUAL SPACE
PCD φ80.0

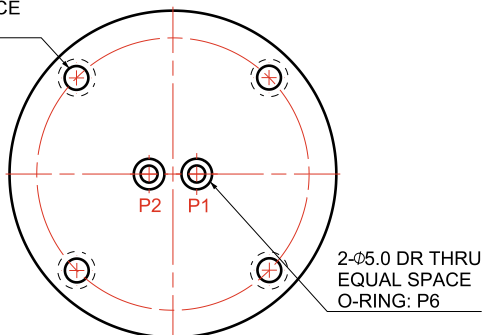

> RTC - 3030G

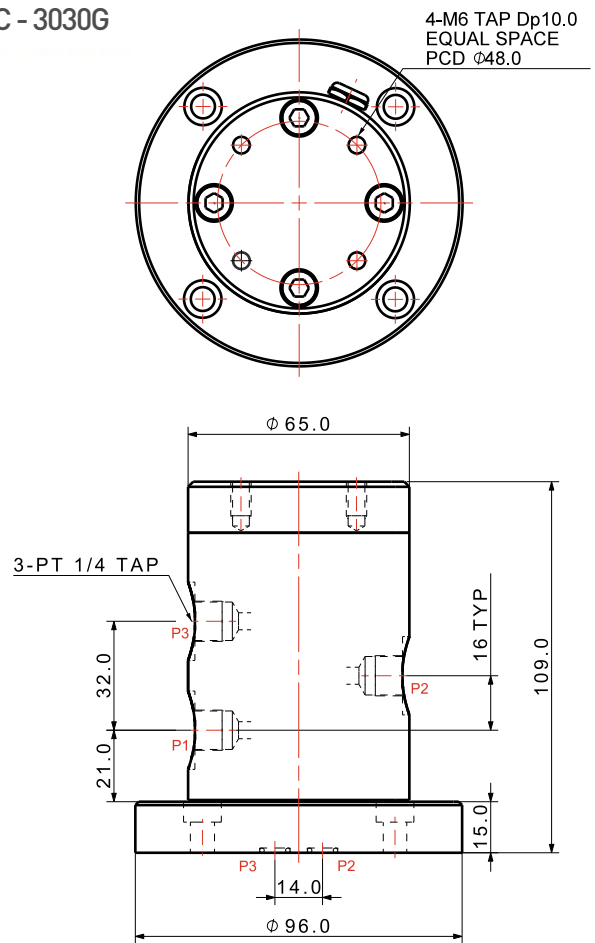

4-φ7.0 DR THRU
φ11.0 C,B Dp6.0
EQUAL SPACE
PCD φ80.0

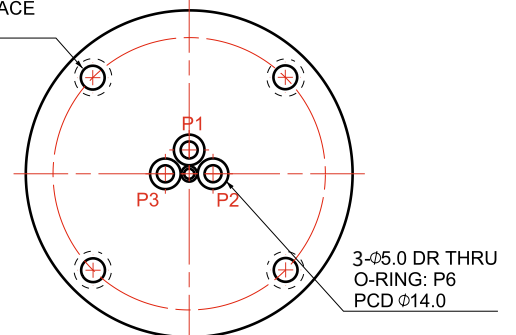

Rotary Joint Flange Type

MODEL NO	RTC-4040G	RTC-5050G
Number of Lines	4	5
Fluid	Hydraulic Oil, Air, Cutting Fluid	
Max. Operating Pressure	150kgf/cm ²	
Max. Revolutions per Minute	120rpm	
Operating Temperature Range	0~70°C	
Weight	3.3 kg	4.9 kg

> RTC - 4040G

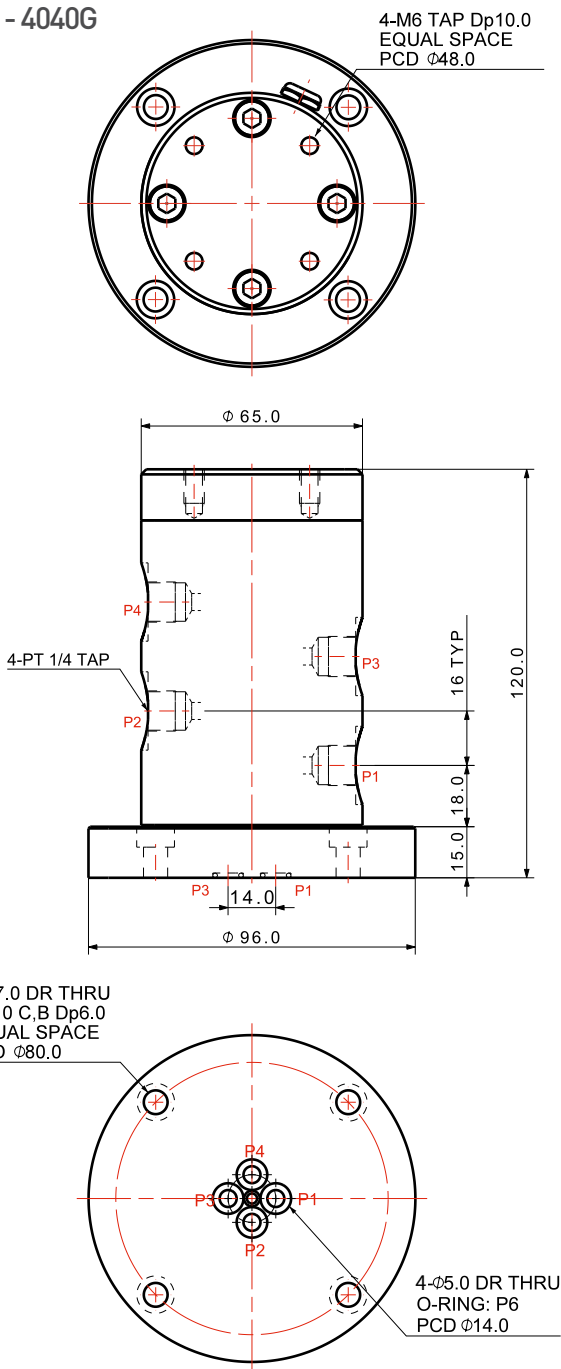

> RTC - 5050G

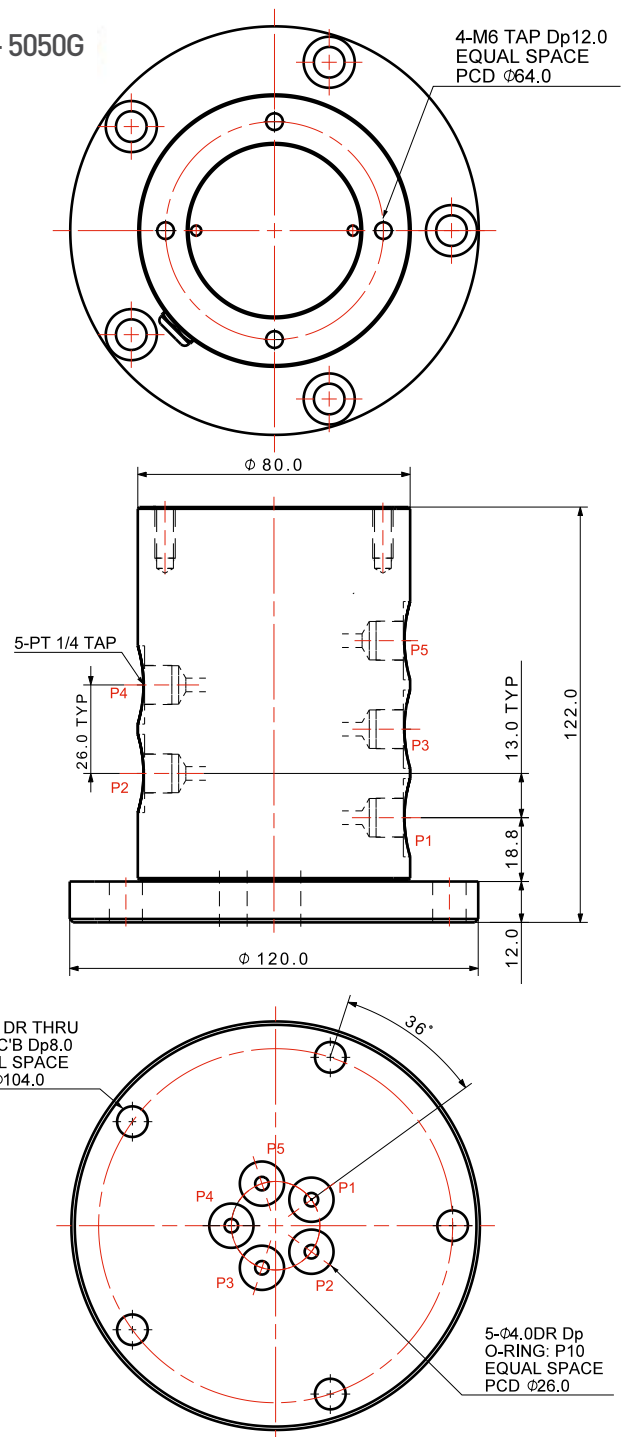

Rotary Joint Flange Type

MODEL NO	RTC-6060G	RTC-8080G
Number of Lines	6	8
Fluid	Hydraulic Oil, Air, Cutting Fluid	
Max. Operating Pressure	150kgf/cm ²	
Max. Revolutions per Minute	120rpm	
Operating Temperature Range	0~70°C	
Weight	5.4 kg	6.5 kg

> RTC - 6060G

> RTC - 8080G

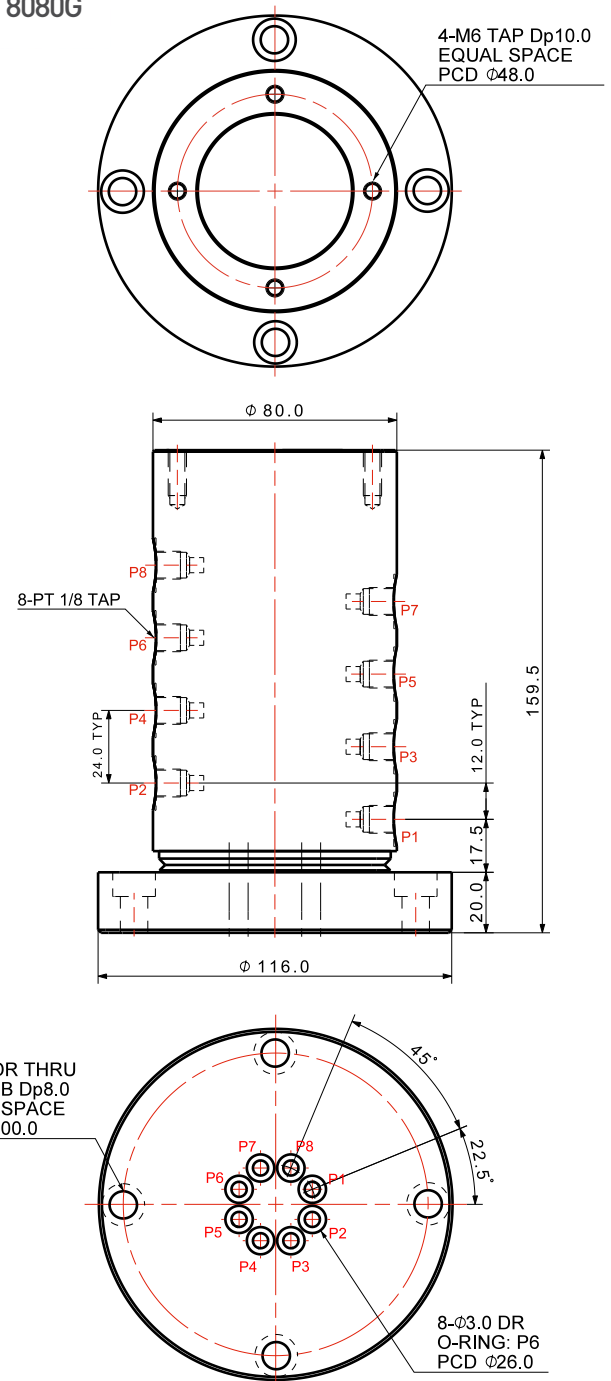
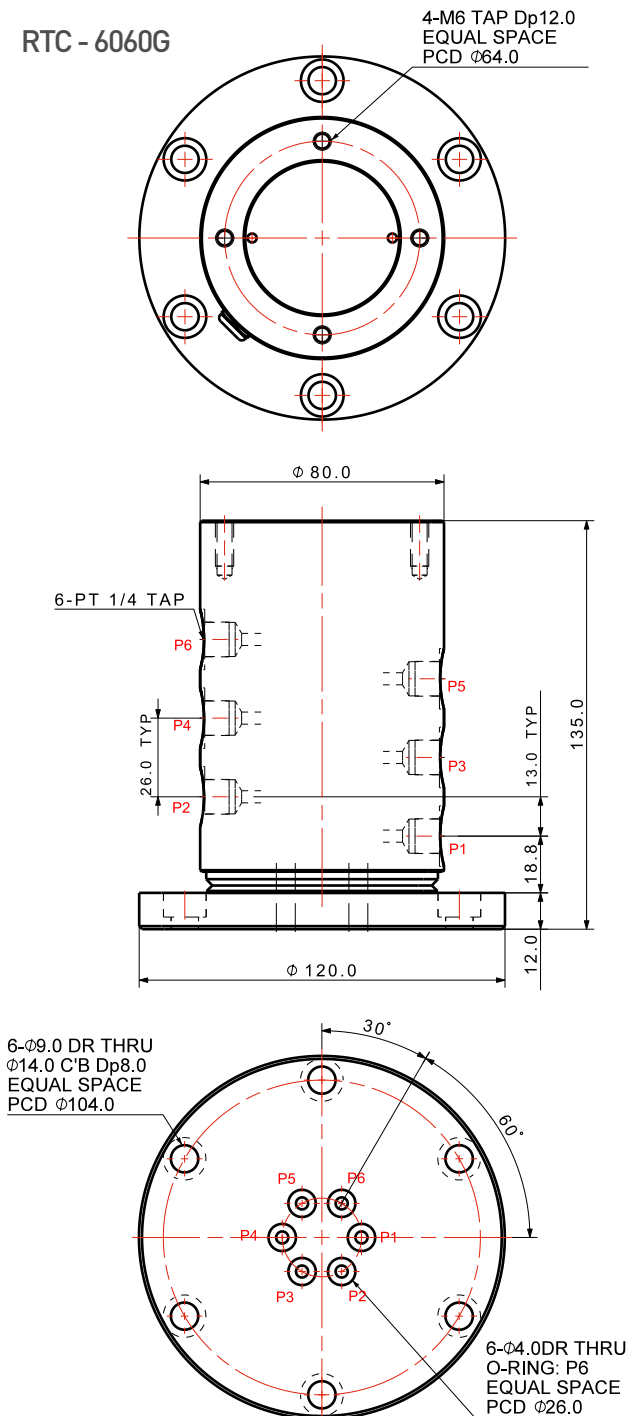

Rotary Joint Cartridge Type



Features

- | | |
|---|---|
| 1. 정지된 유압 공급 라인에서 회전하는 유압 부품에 유압을 공급한다. | 1. Rotary joint supply hydraulic to rotating hydraulic components in the stopped hydraulic supply line. |
| 2. 배관의 꼬임을 방지한다. | 2. It prevents piping twisting. |

Specifications

- | | |
|--|---|
| 1. 최대 공압 사용압력 : 9.9kgf/cm ² | 1. Max. pneumatic operating pressure : 9.9kgf/cm ² |
| 2. 최대 유압 사용압력 : 150kgf/cm ² | 2. Max. hydraulic operating pressure : 150kgf/cm ² |
| 3. 사용온도범위 : 0~70°C | 3. Operating temperature range : 0~70°C |
| 4. 최대 허용 회전수 : 120 rpm | 4. Max. RPM : 120rpm |
| 5. 씰 재질 : 전용씰 | 5. Sealing material : Exclusive seal |
| 6. 사용유체 : 기계 작동유, air, 절삭유 | 6. Fluid : hydraulic, air, cutting oil |

Structure

체결용 장볼트 포함
Long Bolt for Assembling

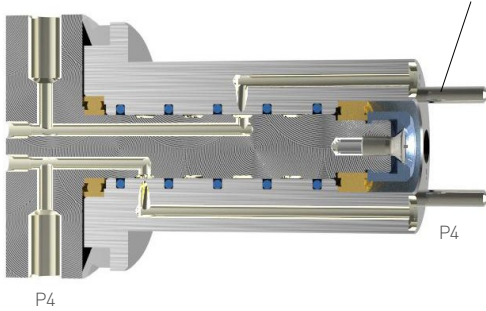

카트리지 타입 로터리 조인트는 인덱스 중공축에 삽입하여 사용하며, 그로 인해 픽스처의 전체 길이가 줄어드는 효과를 얻을 수 있습니다. 또한 외부에서 내측으로 볼트를 취부하는 방식이므로 수리시 기준점에 변화를 주지않아 누구나 손쉽게 교체작업이 가능합니다.

The Cartridge type is inserted into the hollow shaft of the index, thereby reducing the overall length of the fixture. Bolts are mounted from the outside to the inside and there is no change to the reference point during repair for easy replacement.

Application

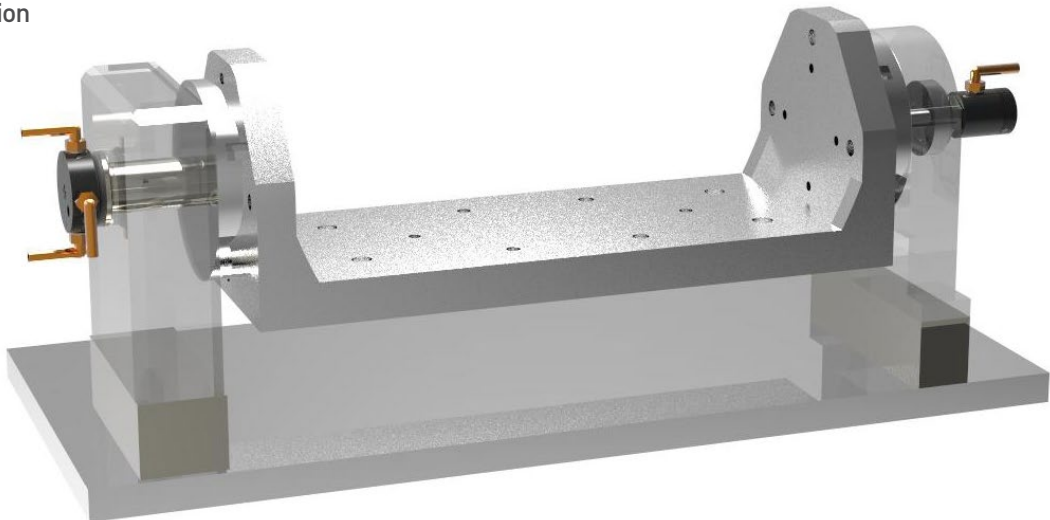

Rotary Joint Cartridge Type

MODEL NO	RTC-4040C	RTC-4045C
Number of Lines	4	4
Fluid	Hydraulic Oil, Air, Cutting Fluid	
Max. Operating Pressure	150kgf/cm ²	
Max. Revolutions per Minute	120rpm	
Operating Temperature Range	0~70°C	
Weight	1.3 kg	1.4 kg

> RTC - 4040C

Torque:
20kgf·cm@0bar
58kgf·cm@150bar

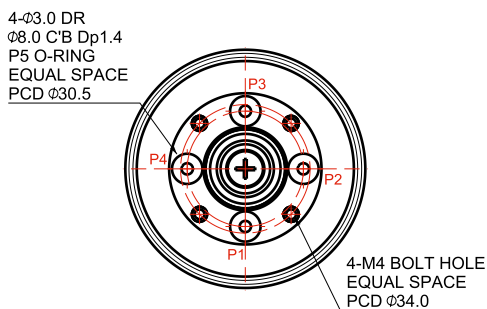
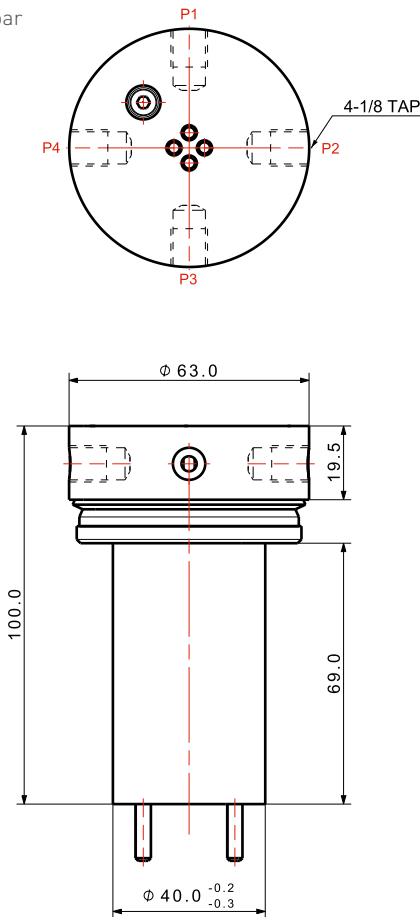

> RTC - 4045C

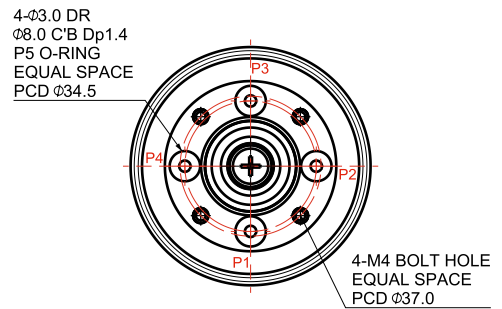
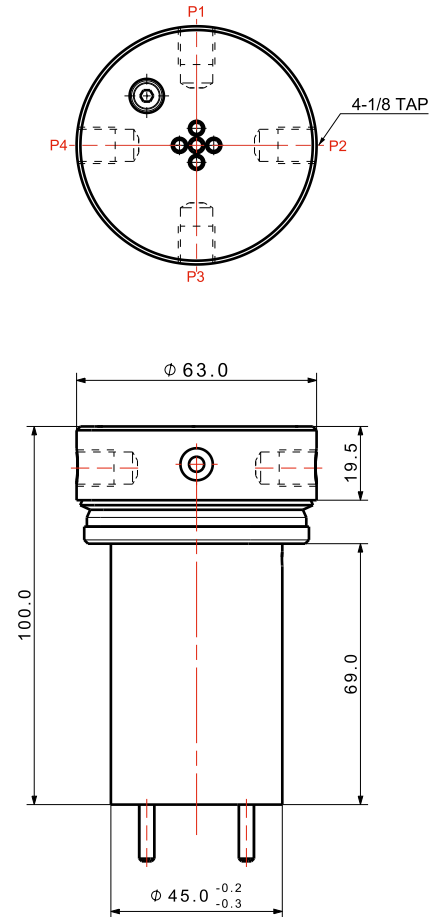

Rotary Joint Cartridge Type

MODEL NO	RTC-5055C	RTC-6055C
Number of Lines	5	6
Fluid	Hydraulic Oil, Air, Cutting Fluid	
Max. Operating Pressure	150kgf/cm ²	
Max. Revolutions per Minute	120rpm	
Operating Temperature Range	0~70°C	
Weight	2.23 kg	2.41 kg

> RTC - 5055C

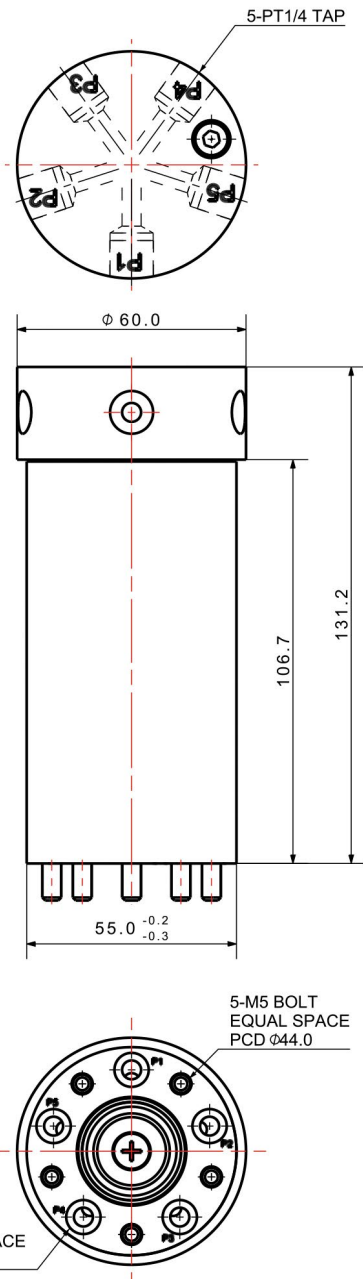

> RTC - 6055C

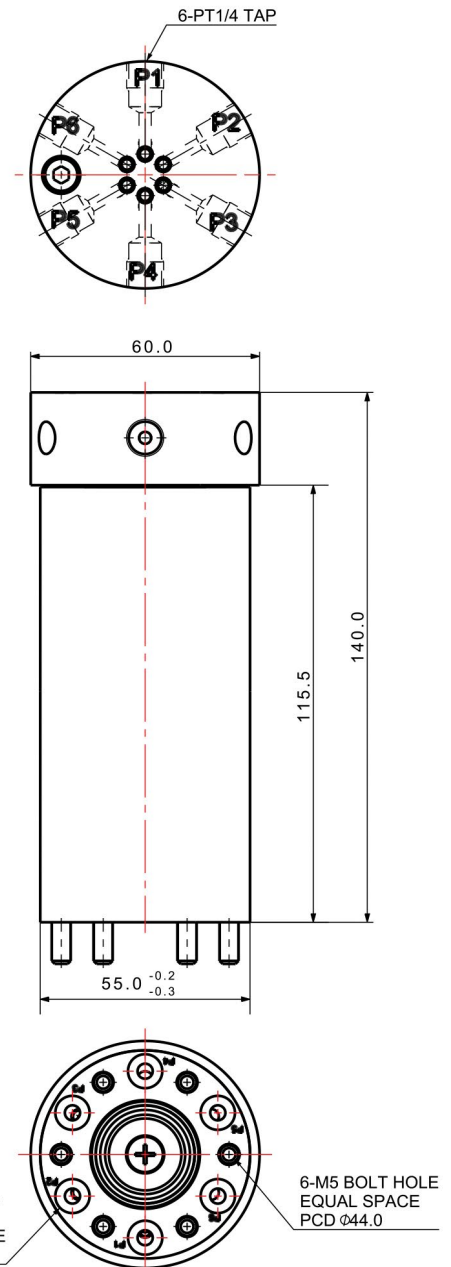

Rotary Joint Cartridge Type

MODEL NO	RTC-5070C	RTC-8070C
Number of Lines	5	8
Fluid	Hydraulic Oil, Air, Cutting Fluid	
Max. Operating Pressure	150kgf/cm ²	
Max. Revolutions per Minute	120rpm	
Operating Temperature Range	0~70°C	
Weight	3.79 kg	4.58 kg

> RTC-5070C

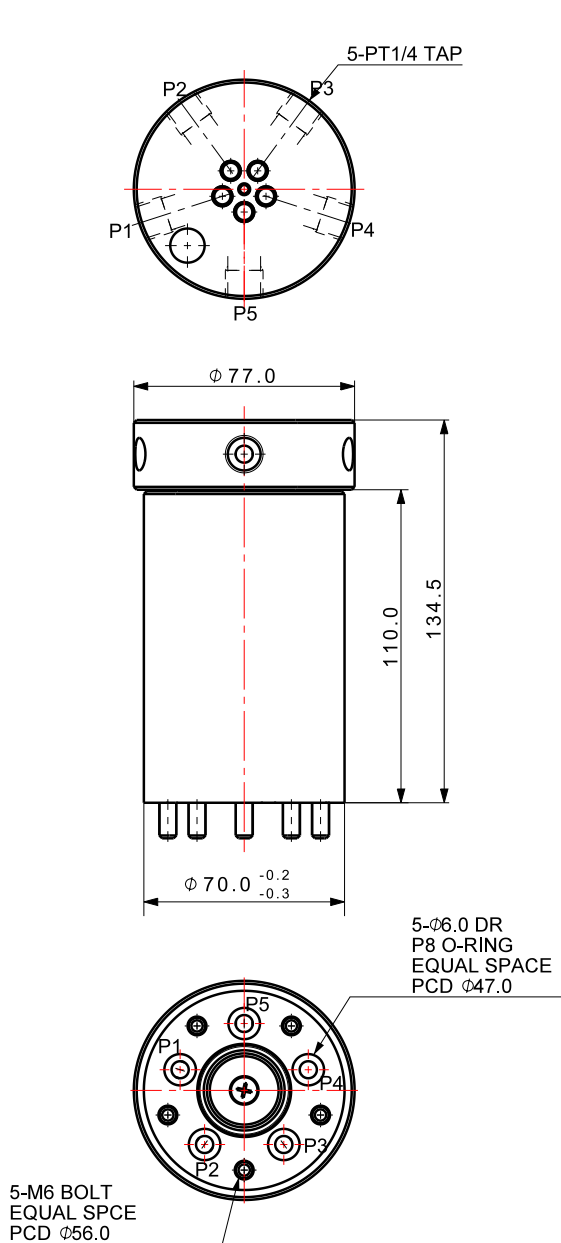

> RTC-8070C

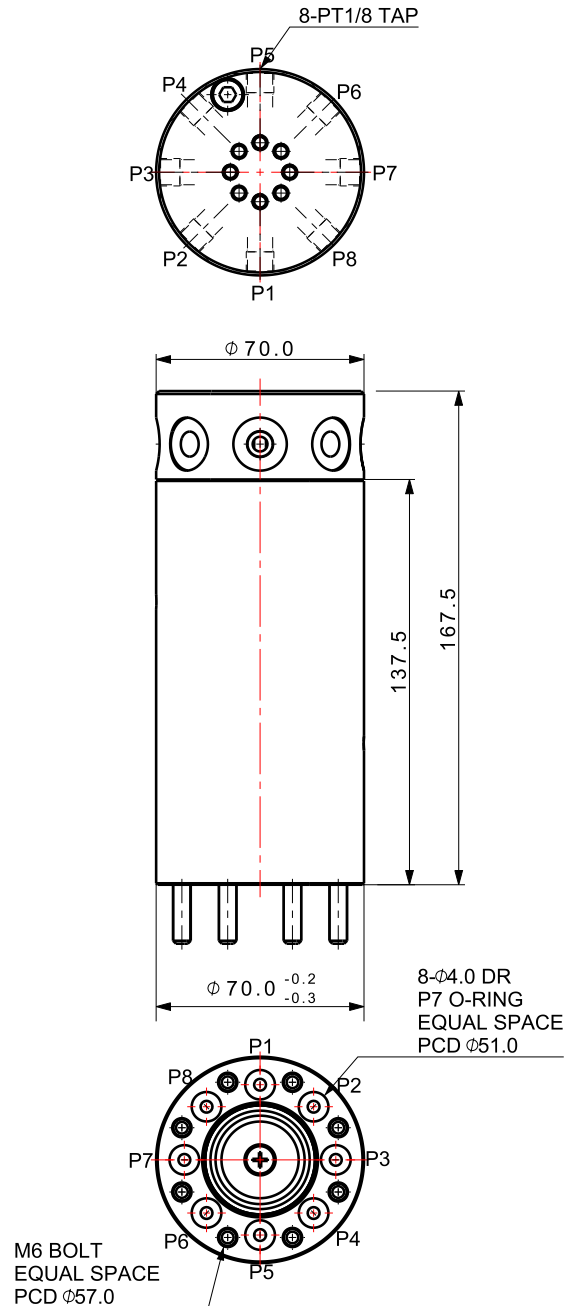

Rotary Joint Compact Flange Type

Features

- | | |
|---|--|
| 1. 정지된 유압 공급 라인에서 회전하는 유압 부품에 유압을 공급한다. | 1. Provides hydraulic to rotating hydraulic parts from fixed hydraulic line. |
| 2. 배관의 꼬임을 방지한다. | 2. Prevents twisted lines. |
| 3. 컴팩트한 사이즈로 수평 픽스처에 설치가 용이 | 3. It is compact and easy to install in horizontal fixture. |

Specifications

- | | |
|--|---|
| 1. 최대 공압 사용압력 : 9.9kgf/cm ² | 1. Max. pneumatic operating pressure : 9.9kgf/cm ² |
| 2. 최대 유압 사용압력 : 100kgf/cm ² | 2. Max. hydraulic operating pressure : 100kgf/cm ² |
| 3. 사용온도범위 : 0~70°C | 3. Operating temperature range : 0~70°C |
| 4. 최대 허용 회전수 : 120 rpm | 4. Max. RPM : 120rpm |
| 5. 씰 재질 : 전용씰 | 5. Sealing material : Exclusive seal |
| 6. 사용유체 : 기계 작동유, air, 절삭유 | 6. Fluid : hydraulic, air, cutting oil |



Structure

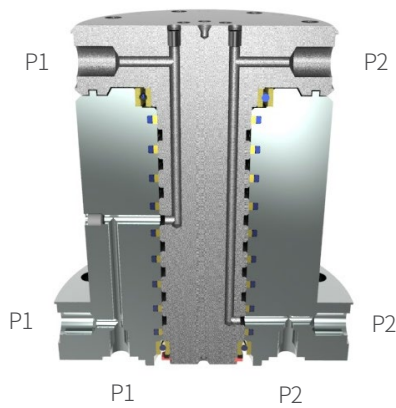

컴팩트 플랜지 타입 로터리 조인트는 공간 차지를 최소화하고 수평 머시닝 센터의 픽스처에 사용하면 편리합니다.

Compact flange type minimizes space occupancy and is convenient to use for fixture of vertical machining center.

Application

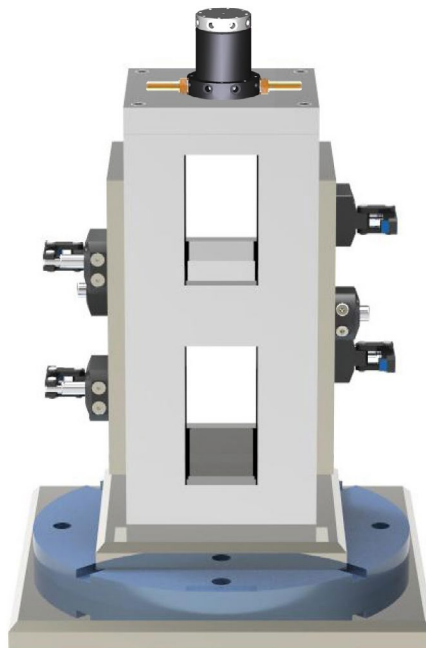

Rotary Joint Compact Flange Type

MODEL NO	RTC-020	RTC-040
Number of Lines	2	4
Fluid	Hydraulic Oil, Air, Cutting Fluid	
Max. Operating Pressure	100kgf/cm ²	
Max. Revolutions per Minute	120rpm	
Operating Temperature Range	0~70°C	
Weight	4.36 kg	5.34 kg

> RTC - 020

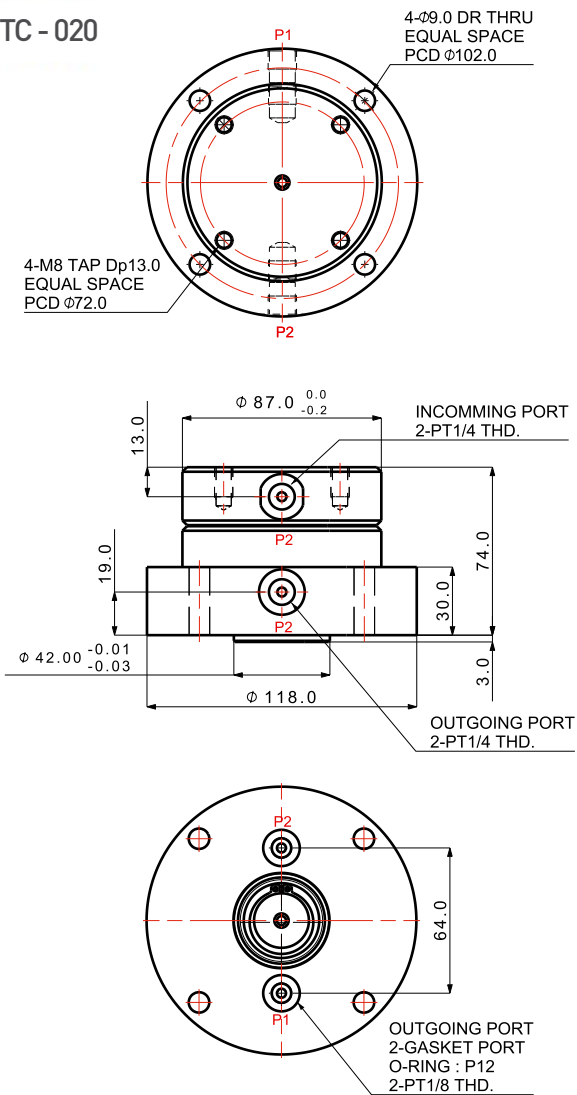

> RTC - 040

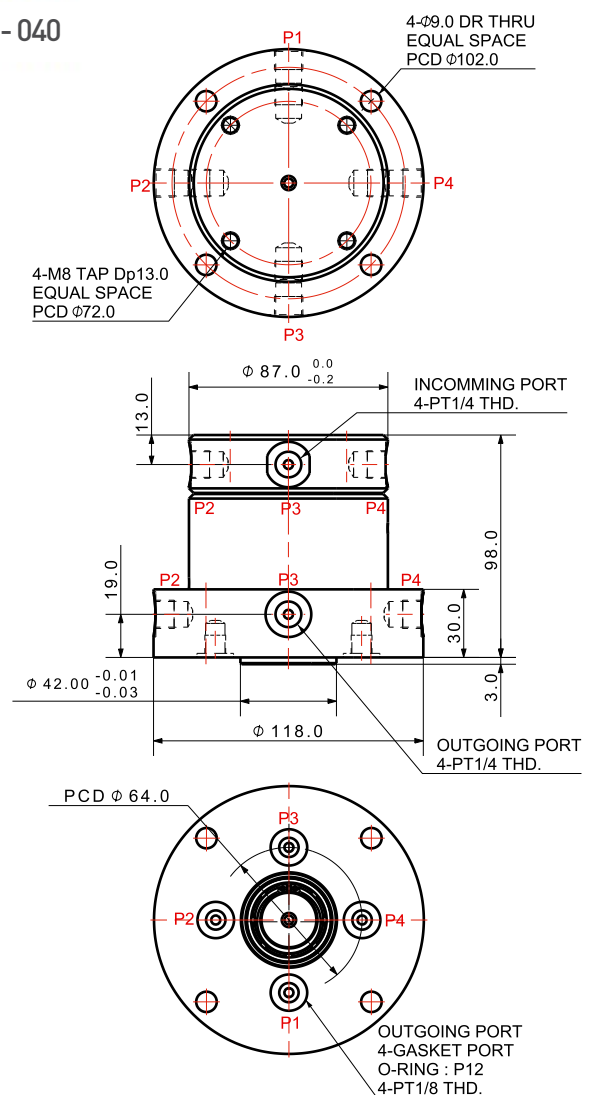

Rotary Joint Compact Flange Type

MODEL NO	RTC-060	RTC-080
Number of Lines	6	8
Fluid	Hydraulic Oil, Air, Cutting Fluid	
Max. Operating Pressure	100kgf/cm ²	
Max. Revolutions per Minute	120rpm	
Operating Temperature Range	0~70°C	
Weight	7.75 kg	8.98 kg

> RTC - 060

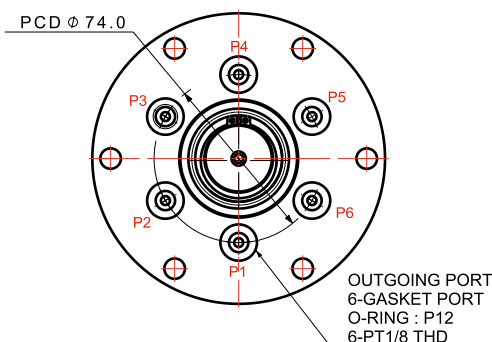
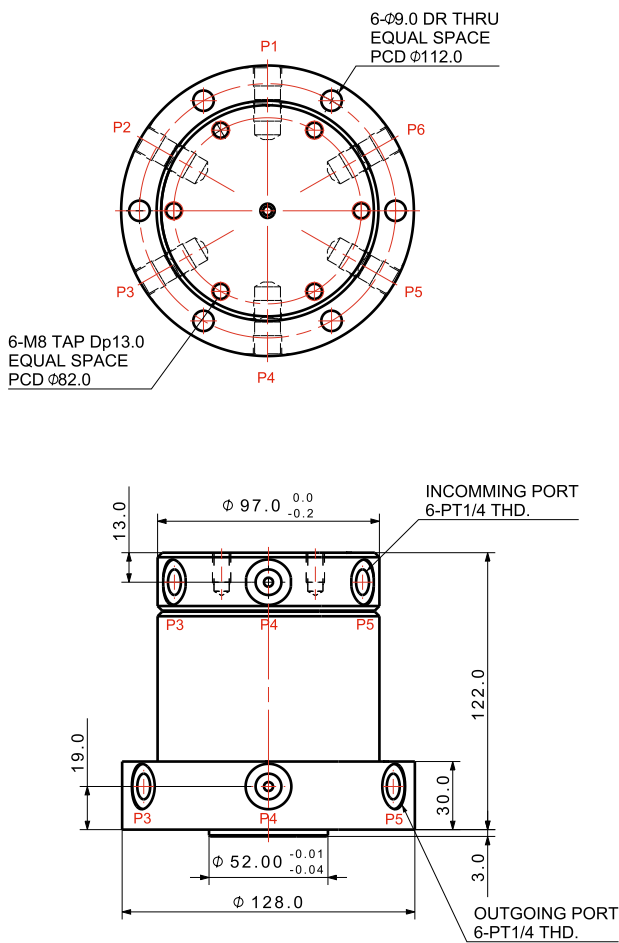

> RTC - 080

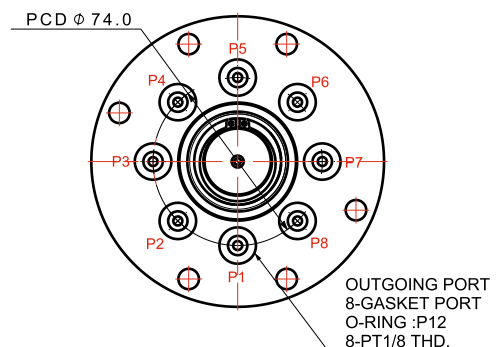
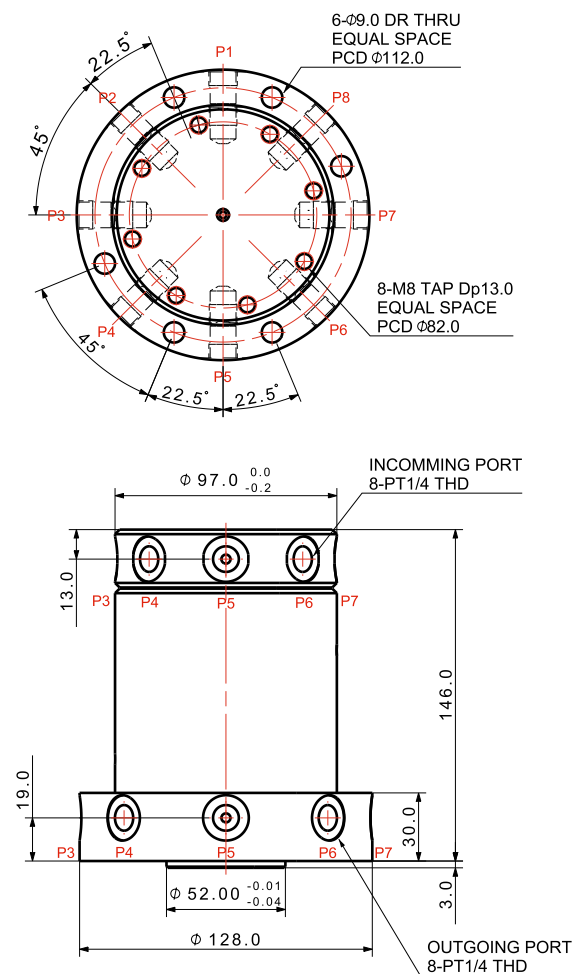

Compact Rotary Joint Compact Flange Type

MODEL NO	RTC-120	RTC-160
Number of Lines	12	16
Fluid	Hydraulic Oil, Air, Cutting Fluid	
Max. Operating Pressure	100kgf/cm ²	
Max. Revolutions per Minute	120rpm	
Operating Temperature Range	0~70°C	
Weight	18.56 kg	24.88 kg

> RTC - 120

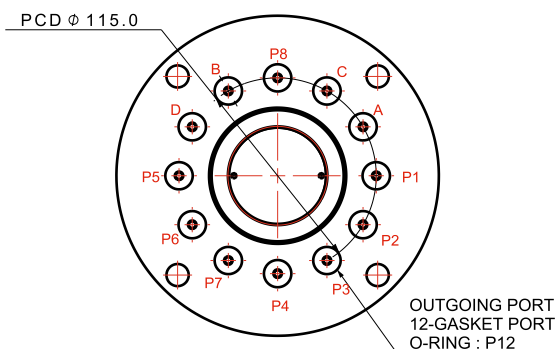
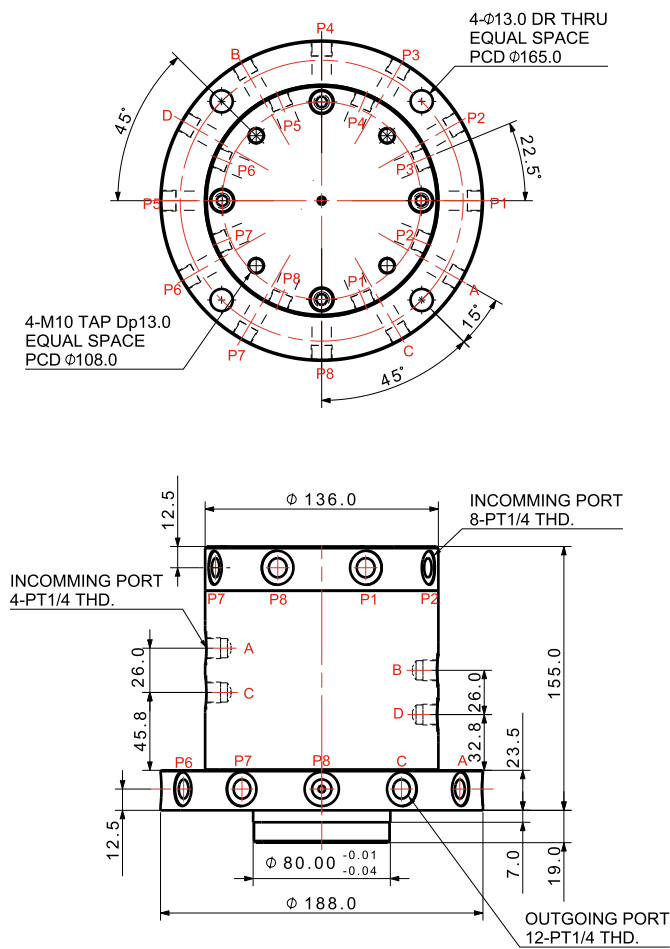

> RTC - 160

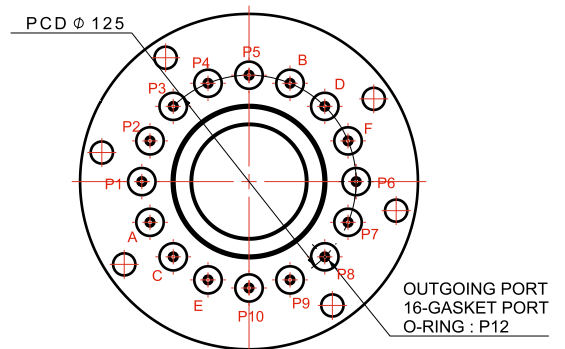
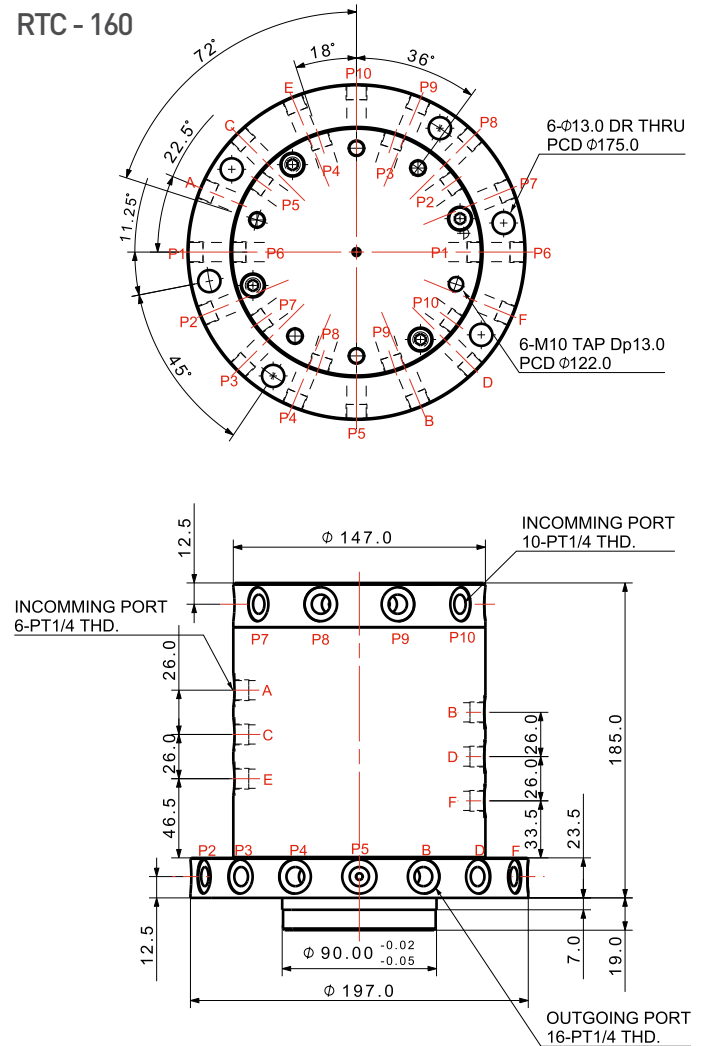

Rotary Joint Top Type



Features

1. 정지된 유압 공급 라인에서 회전하는 유압 부품에 유압을 공급한다.
2. 배관의 꼬임을 방지한다.
1. Rotary joint supply hydraulic to rotating hydraulic components in the stopped hydraulic supply line.
2. It prevents piping twisting.

Specifications

1. 최대 공압 사용압력 : 9.9kgf/cm²
2. 최대 유압 사용압력 : 150kgf/cm²
3. 사용온도범위 : 0~70°C
4. 최대 허용 회전수 : 120 rpm
5. 씰 재질 : 전용씰
6. 사용유체 : 기계 작동유, air, 절삭유
1. Max. pneumatic operating pressure : 9.9kgf/cm²
2. Max. hydraulic operating pressure : 150kgf/cm²
3. Operating temperature range : 0~70°C
4. Max. RPM : 120rpm
5. Sealing material : Exclusive seal
6. Fluid : hydraulic, air, cutting oil

Structure

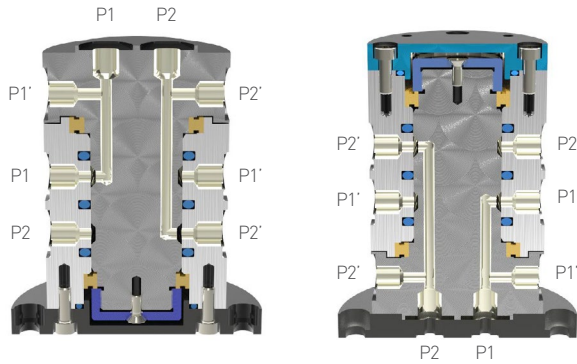

탑 타입 로터리 조인트는 인덱스 테이블을 이용한 조립 또는 가공전용기에 사용하기 편리하며 또한 수평 머시닝 센터의 픽스처에 사용하기도 편리합니다.

It is useful for exclusive processing machine or assembly with index table as well as fixture of horizontal machining center.

Application

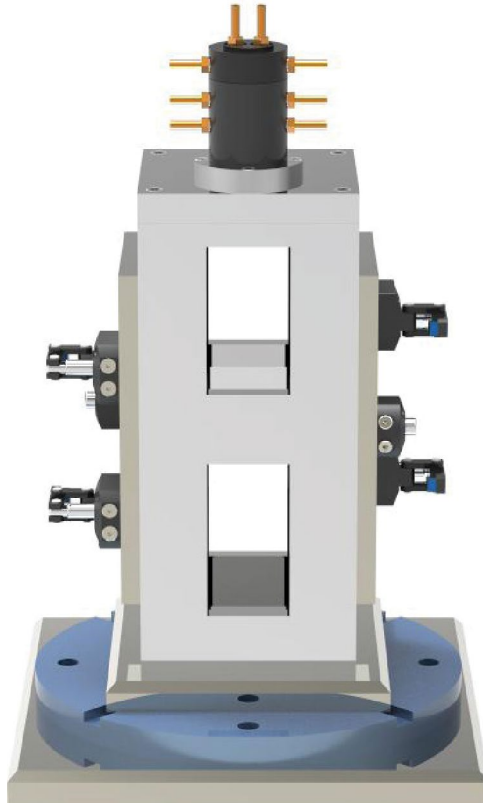

Rotary Joint Top Type

MODEL NO	RTC-2020	RTC-2020S
Number of Lines	2	2
Fluid	Hydraulic Oil, Air, Cutting Fluid	
Max. Operating Pressure	150kgf/cm ²	
Max. Revolutions per Minute	120rpm	
Operating Temperature Range	0~70°C	
Weight	5.0 kg	5.5 kg

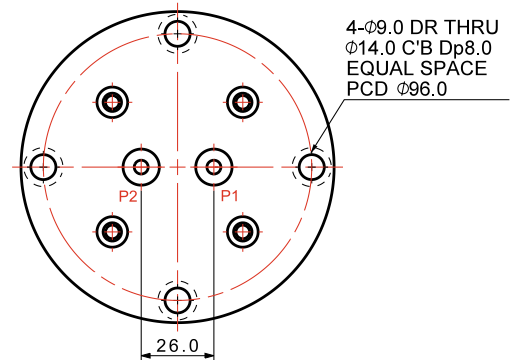
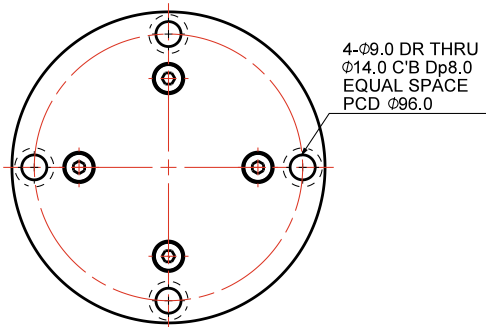
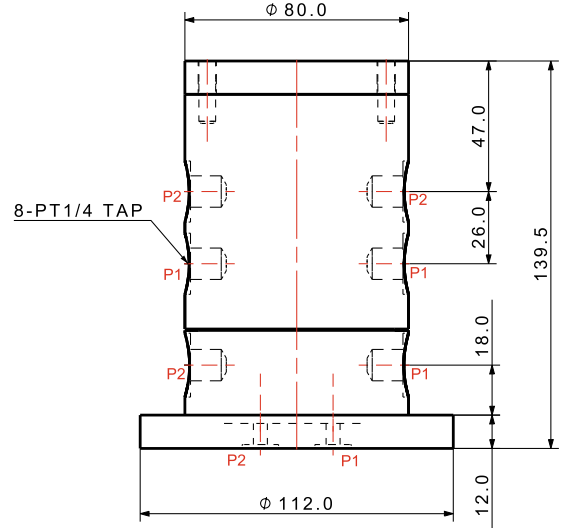
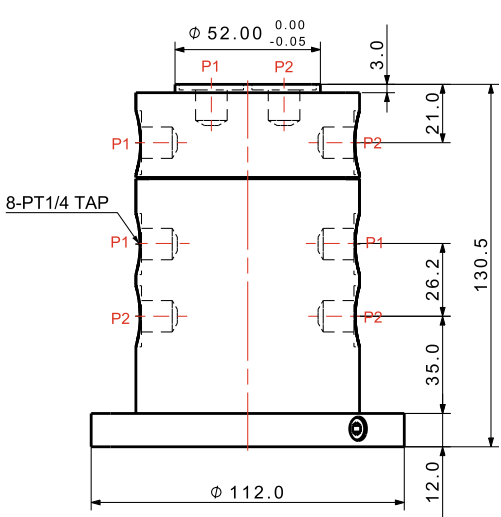
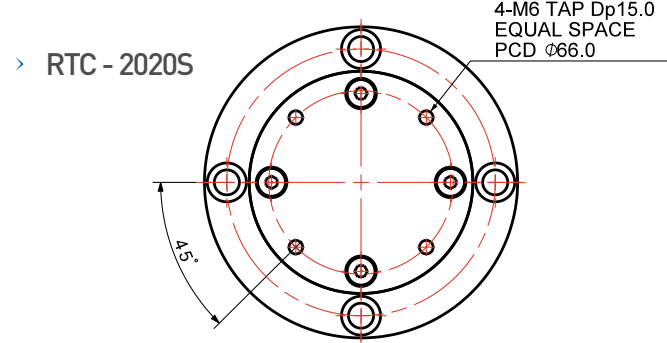
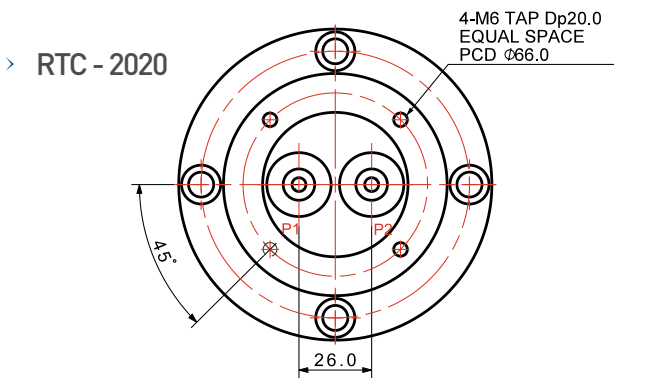

Rotary Joint Top Type

MODEL NO	RTC-4050	RTC-8090
Number of Lines	4	8
Fluid	Hydraulic Oil, Air, Cutting Fluid	
Max. Operating Pressure	150kgf/cm ²	
Max. Revolutions per Minute	120rpm	
Operating Temperature Range	0~70°C	
Weight	10 kg	13 kg

> RTC - 4050

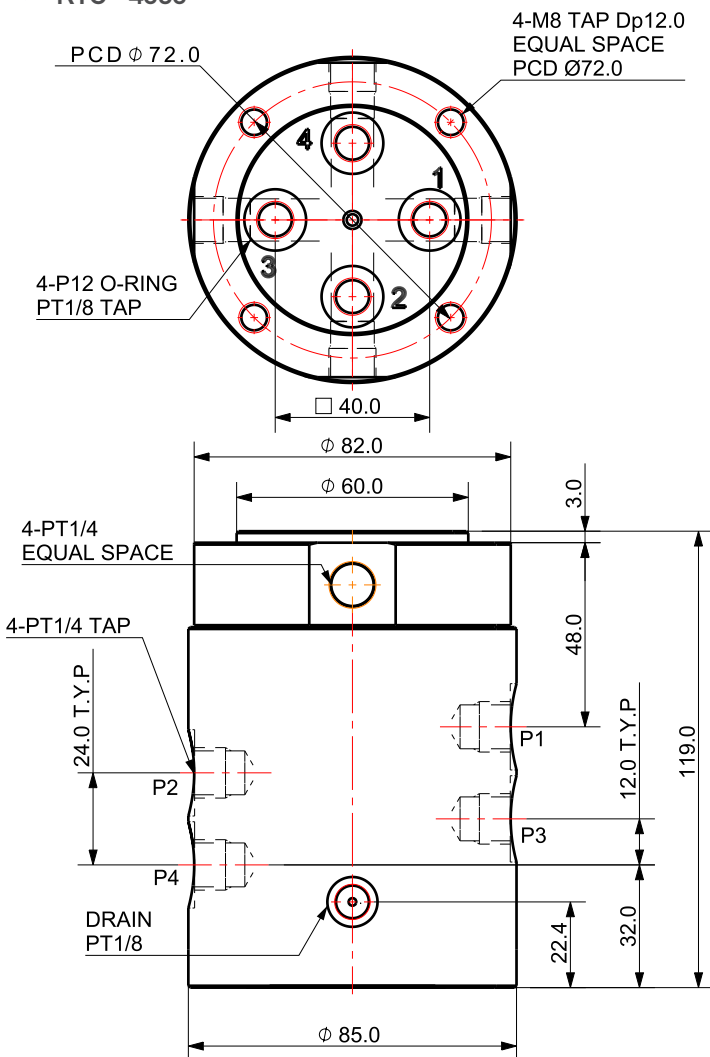

> RTC - 8090

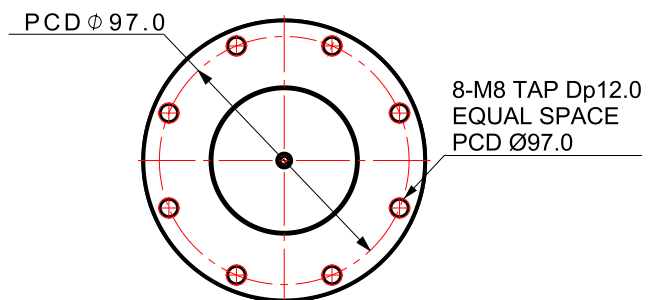
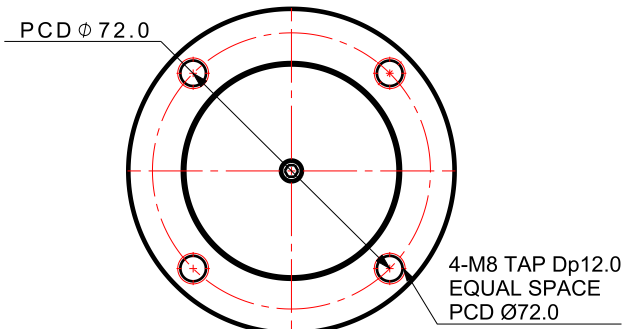
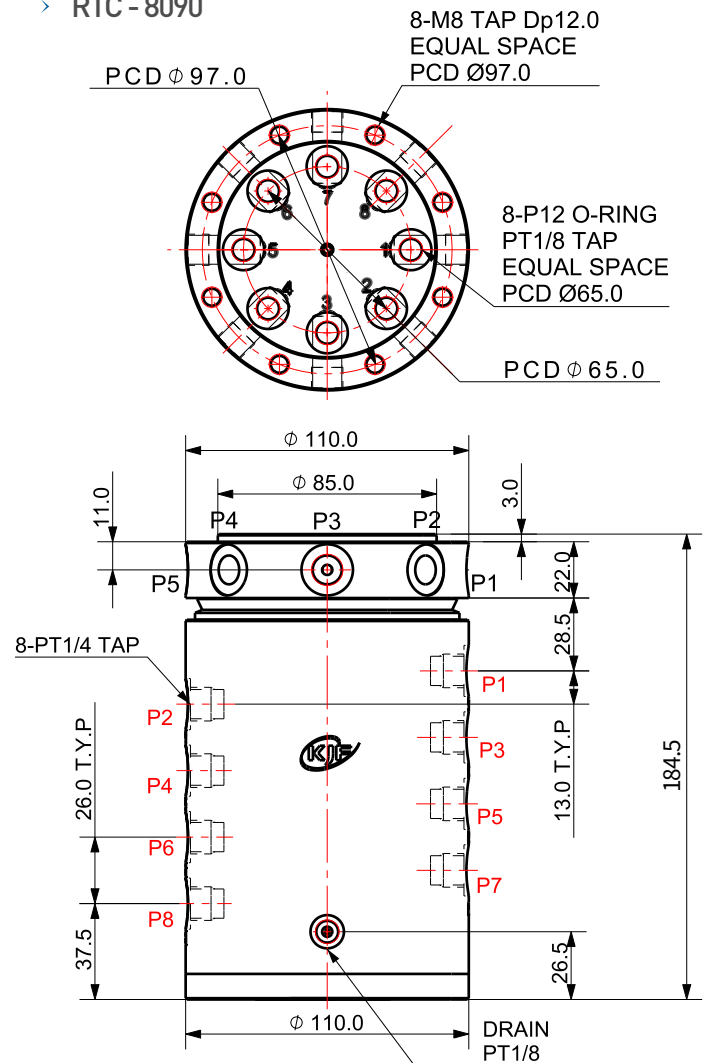

Memo





Rotary Joint Male Type

Features

- | | |
|---|---|
| 1. 정지된 유압 공급 라인에서 회전하는 유압 부품에 유압을 공급한다. | 1. Rotary joint supply hydraulic to rotating hydraulic components in the stopped hydraulic supply line. |
| 2. 배관의 꼬임을 방지한다. | 2. It prevents piping twisting. |

Specifications

- | | |
|--|---|
| 1. 최대 공압 사용압력 : 9.9kgf/cm ² | 1. Max. pneumatic operating pressure : 9.9kgf/cm ² |
| 2. 최대 유압 사용압력 : 150kgf/cm ² | 2. Max. hydraulic operating pressure : 150kgf/cm ² |
| 3. 사용온도범위 : 0~70°C | 3. Operating temperature range : 0~70°C |
| 4. 최대 허용 회전수 : 120 rpm | 4. Max. RPM : 120rpm |
| 5. 씰 재질 : 전용씰 | 5. Sealing material : Exclusive seal |
| 6. 사용유체 : 기계 작동유, air, 절삭유 | 6. Fluid : hydraulic, air, cutting oil |

Structure

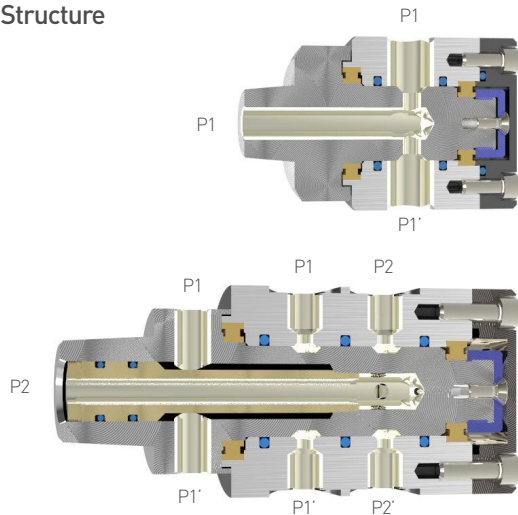

메일 타입 로터리 조인트는 설치 할 위치에 PT 탭으로 고정합니다.

The male type should be secured with PT tap to the installation location.

Application

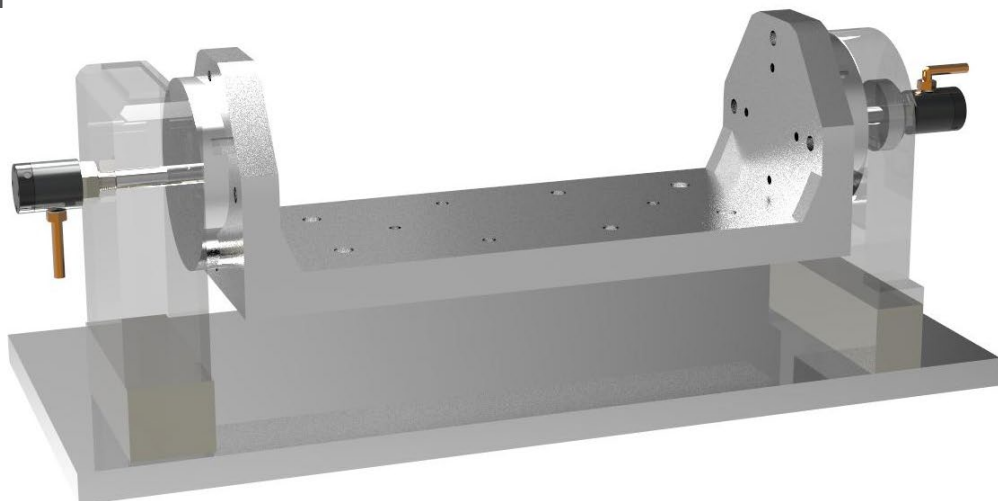

Rotary Joint Male Type

MODEL NO	RTC-3814	RTC-3412
Number of Lines	1	1
Fluid	Hydraulic Oil, Air, Cutting Fluid	
Max. Operating Pressure	150kgf/cm ²	
Max. Revolutions per Minute	120rpm	
Operating Temperature Range	0~70°C	
Weight	0.55 kg	1.93 kg

> RTC - 3814

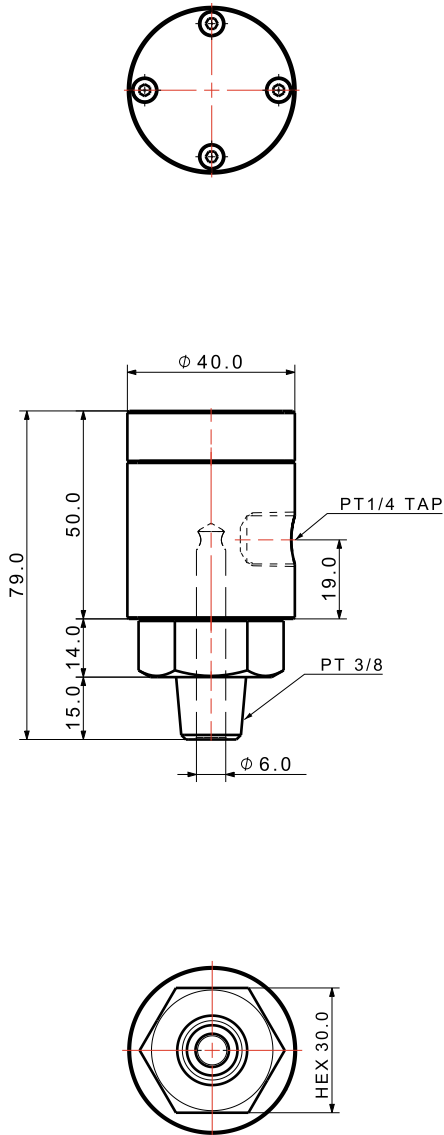

> RTC - 3412

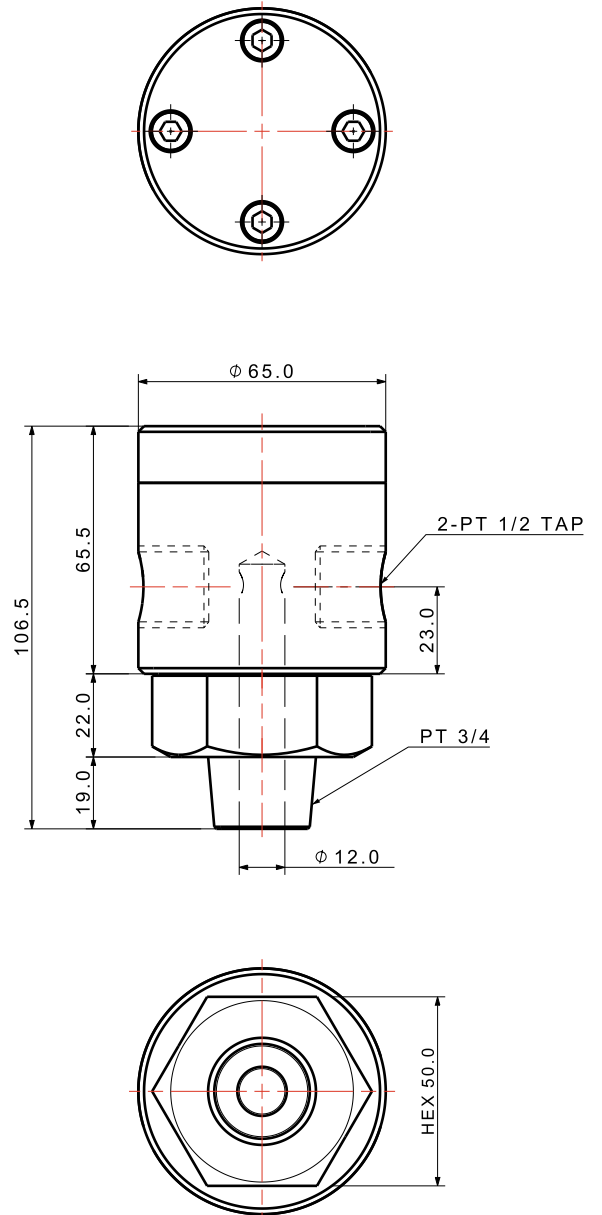

Rotary Joint Male Type

MODEL NO	RTC-3414	RTC-1014
Number of Lines	2	2
Fluid	Hydraulic Oil, Air, Cutting Fluid	
Max. Operating Pressure	150kgf/cm ²	
Max. Revolutions per Minute	120rpm	
Operating Temperature Range	0~70°C	
Weight	2.7 kg	2.7 kg

> RTC-3414

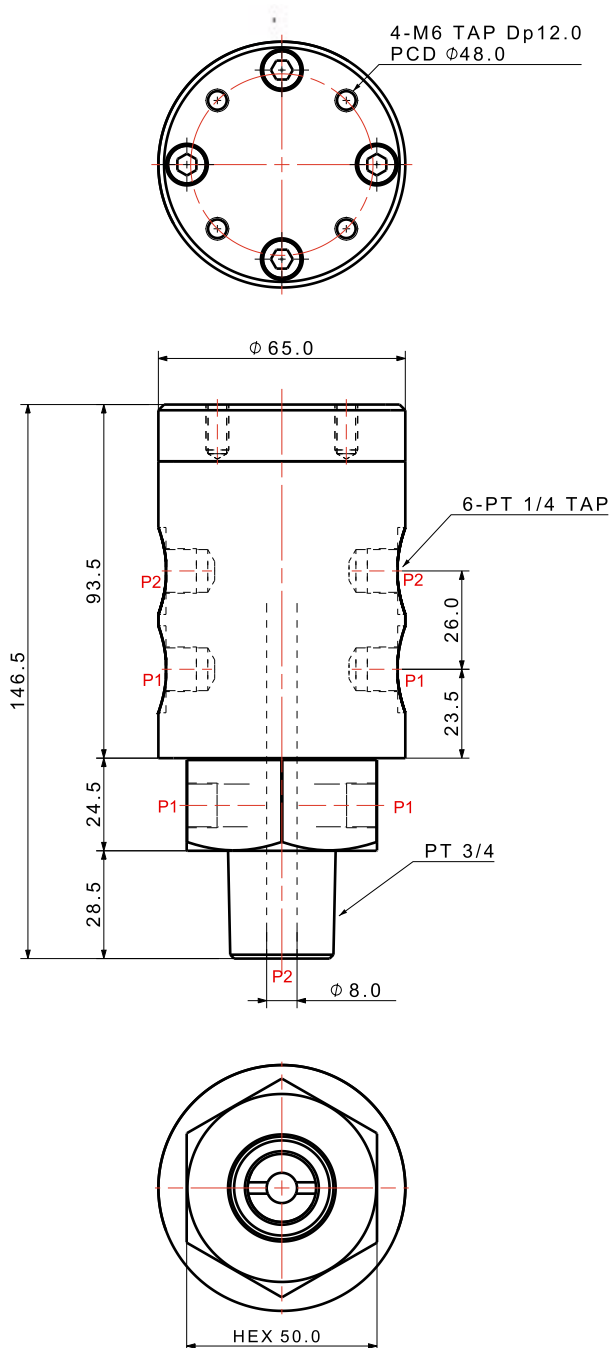

> RTC-1014

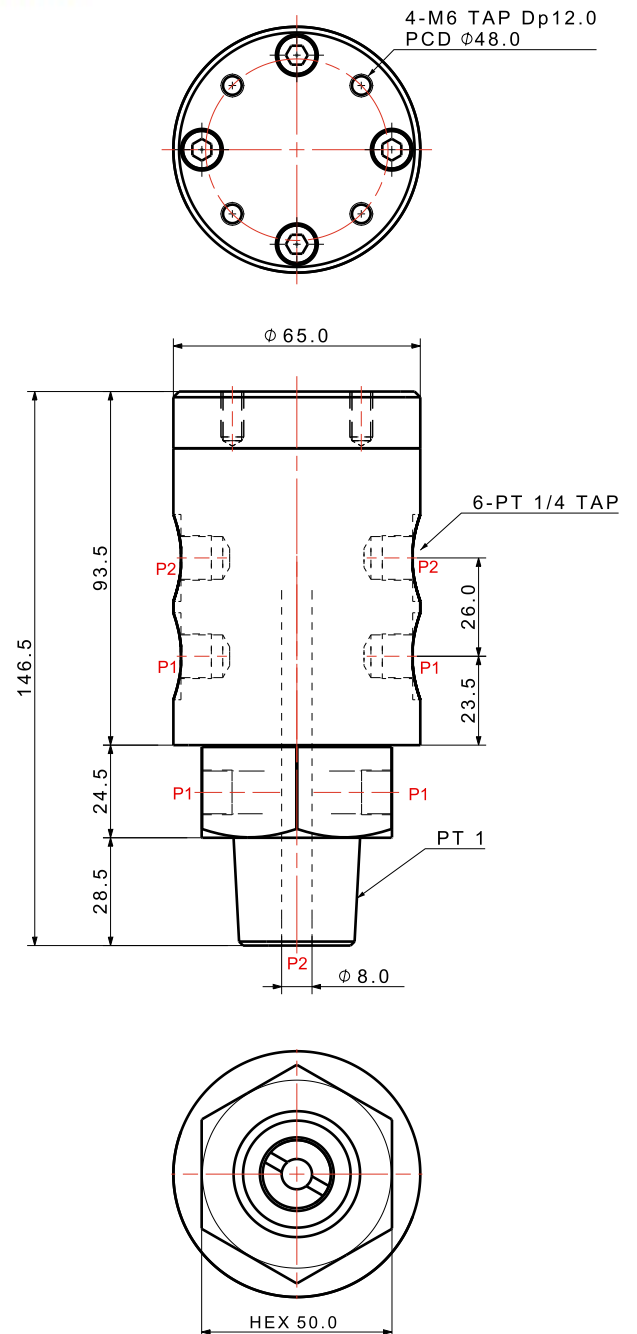

Rotary Joint

사용할 때 주의할 점 Comments and cautions for operation

1. 로터리 조인트를 설치할 때 로터리와 하우징의 중심을 일치시키는 것이 매우 중요합니다.

1. It is very important to match the center of rotary and housing when installing rotary joint.

A. 로터리 조인트를 설치할 때, 회전부품은 견고하게 고정하고 회전하지 않는 부품은 느슨하게 고정해서, 회전하는 부품을 회전하지 않는 부품이 자연스럽게 따라 움직이도록 해야 합니다. (아래 그림 참조)

A. When installing a rotary joint, the rotating component should be fixed firmly and the non-rotating component should be loosely fastened. In doing so, the rotating components should move naturally following non-rotating components.

C. 회전하지 않는 부품이 따라 돌지않게 브라켓을 설치할 때도, 느슨하게 묶어서 회전하지 않는 부품이 회전하는 부품을 자연스럽게 따라 움직이는데 방해되지 않도록 해야합니다. (아래 그림 참조)

C. When installing the bracket to prevent rotation of non-rotating components following rotating components, the bracket should be fastened loosely so as not to interfere with the natural movement of the rotating components.

B. 배관시 회전하는 부품에는 스틸 파이프도 배관해도 무관하지만, 회전하지 않는 부품은 반드시 여유 있는 길이의 호스로 배관해야만 합니다.

B. Parts that rotate during piping may be connected with steel pipes, but parts that do not rotate must be connected with a hose of sufficient length.

2. 로터리 조인트를 연속 회전시키면, SEAL의 마찰에 의해 열이 발생하므로 열을 식히는 방안을 강구하든지, 단속적으로 회전하는 경우에 사용이 적합합니다.

2. When rotary joint is continuously rotating, heat is generated by the friction of seal. Therefore, provide a measure to cool the heat or use in case of intermittent rotation.

3. 인덱스를 이용하여 회전시킬 때, 처음 토크를 참조하여 모터를 선정하십시오.

3. When using the index to rotate, select the motor referring to the first torque.

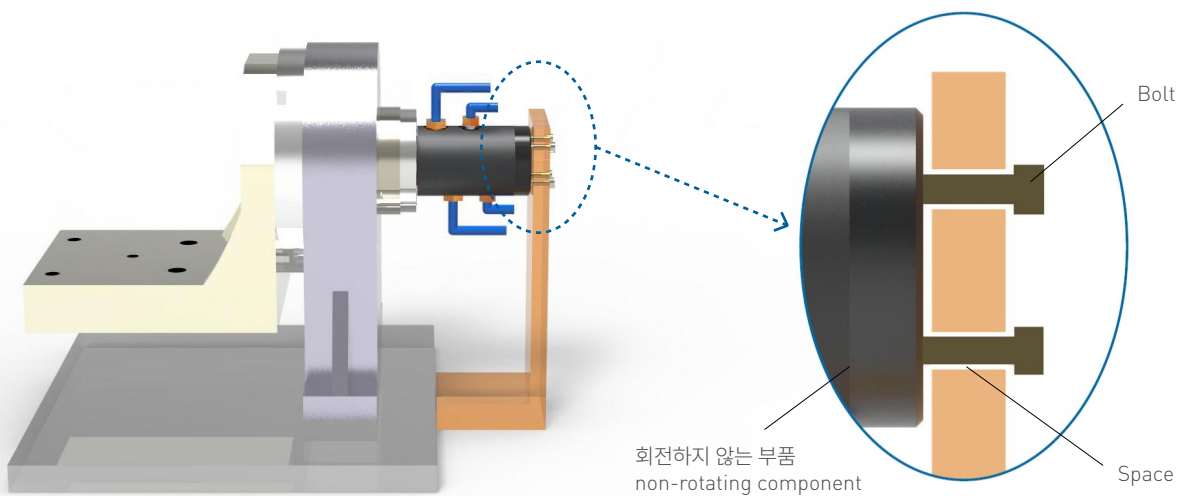

* 로터리조인트를 설치할 때 회전하지 않는 부품은 회전하는 부품을 따라 움직일 수 있도록 느슨하게 고정하여야 합니다.

When installing a rotary joint, non-rotating component should be loosely secured so that they can move along with the rotating component.

Rotary Distributors Valve

Application

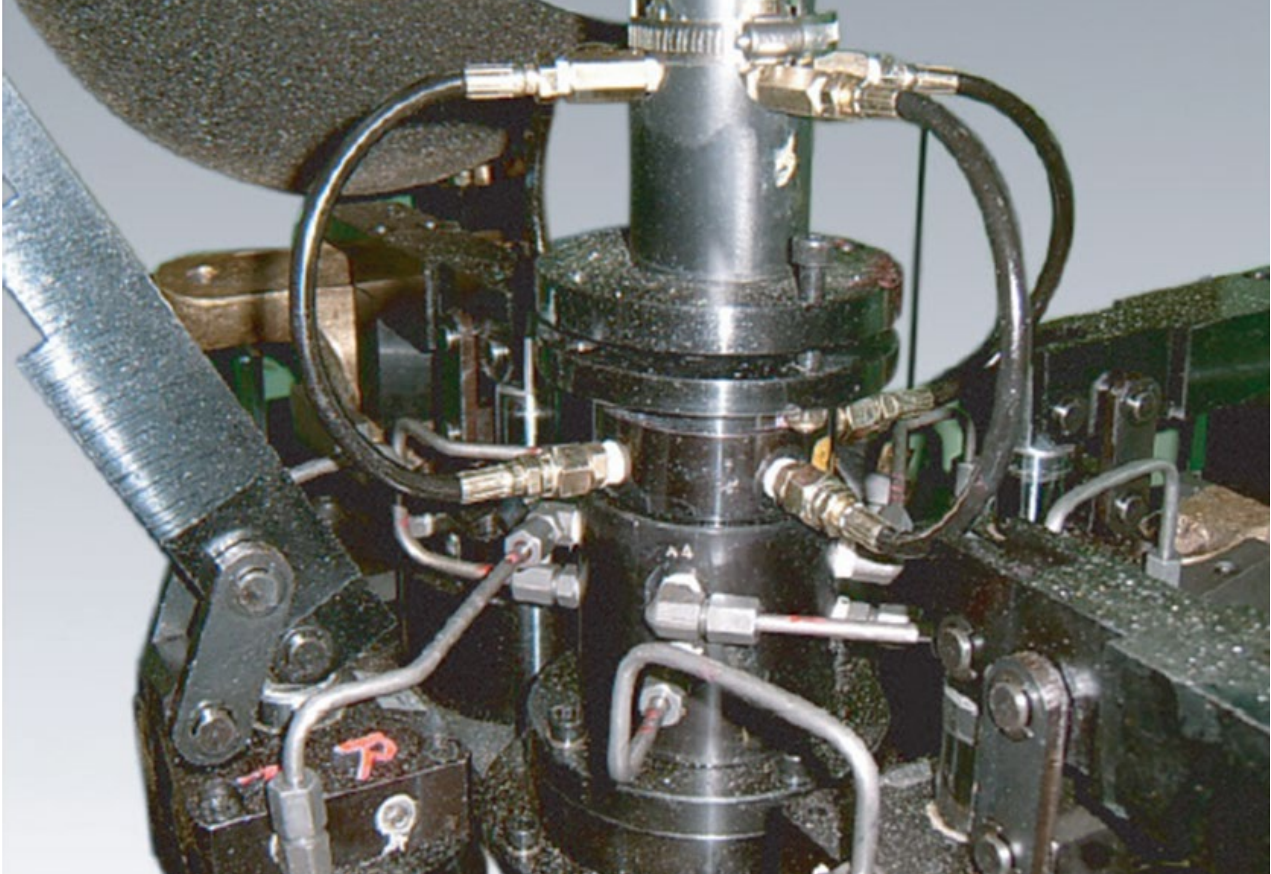

Circuit Diagram

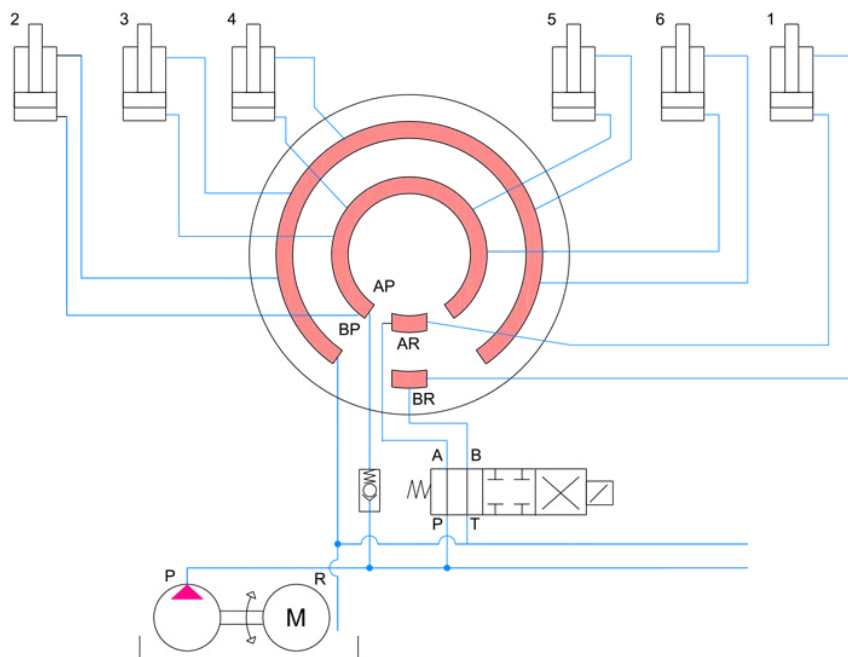



Rotary Distributors Valve

Features

1. 로터리 조인트에 분배기능과 밸브기능을 추가한 제품으로 로터리 테이블을 이용한 전용기를 제작할 때 활용하면 매우 편리하다.
2. 주문생산품이다.
1. Distribution and valve functions added to rotary joint and it is very convenient to use when making a dedicated machine using rotary table.
2. Custom-made.

Specifications

1. 작동 압력 : 5~200kgf/cm²
2. 사용 온도 : 0~60°C
3. 씰의 재료 : 전용씰
1. Operating Pressure : 5~200kgf/cm²
2. Operating Temperature : 0~60°C
3. Seal Material : Exclusive seal

> RDV - XX 20

①

① Number of Stations

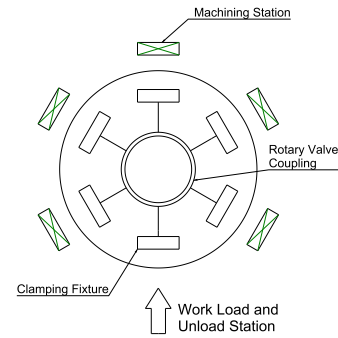

주의사항 Caution

완전히 고정하지 말 것.
구멍을 크게 가공하여 움직일 수 있게 할 것.
회전시 힘만 잡아주면 됨.

Do not tighten fully.
Make holes large enough to move.
Only strength requires control when rotating.

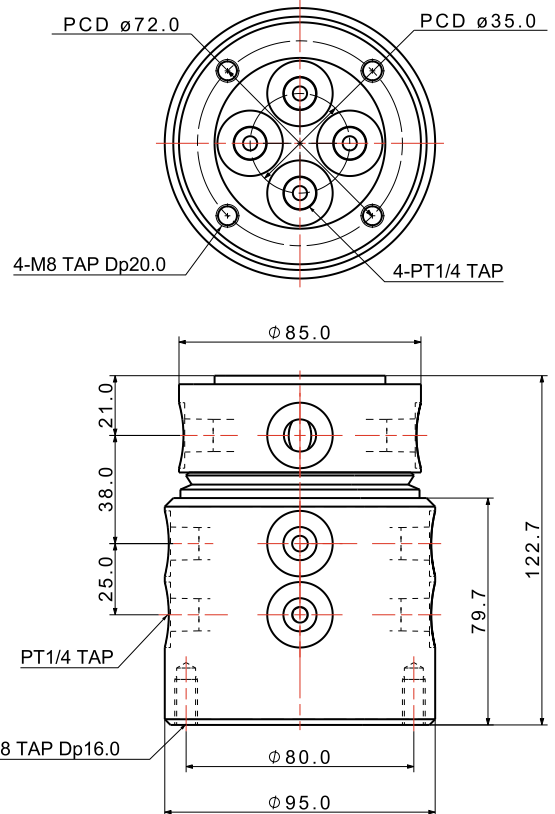
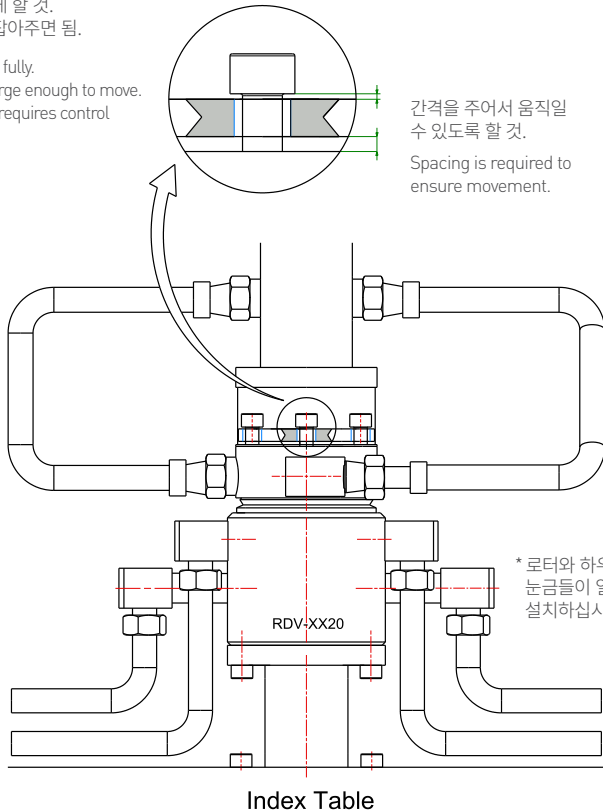



Hydraulic Intensifier

Features

1. 픽스처에 공급압을 높이고자 하나 메인압을 높일 수 없을 때 간단하게 해결 가능한 기기입니다.
 2. 픽스처 안의 전체 혹은 일부분만 압력을 높여 사용할 수 있다.
1. This device is a simple solution when the mains pressure cannot be increased while trying to increase supply pressure to fixture.
 2. All or part of fixture can be used by increasing the pressure within.

Specifications

1. 작동압력 : 10~160kgf/cm²
 2. 사용온도 : 0~60°C
1. Operating Pressure : 10~160kgf/cm²
 2. Operating Temperature : 0~60°C

> HHB - 02 02

- ① Intensification Ratio ② High Pressure Volume

Specification

MODEL NO.	Intensification Ratio	Input Pressure Range(kgf/cm ²)	High Pressure Volume (cm ³)	Max Output Pressure (kgf/cm ²)	Weight (kg)
HHB-0202	2.5 : 1	10~160	20	400	4.25
HHB-0402	4 : 1	10~100	20	400	5.10
HHB-0602	6 : 1	10~66	20	400	5.85

Dimensions

MODEL NO.	DIMENSIONS (mm)						
	øA	B	C	D	E	F	G
HHB-0202	78	121	157	30	M50xP1.5	PT 1/4	PT 3/8
HHB-0402	88	120	160	33	M50xP1.5	PT 1/4	PT 3/8
HHB-0602	88	140	197	50	M50xP1.5	PT 1/4	PT 3/8

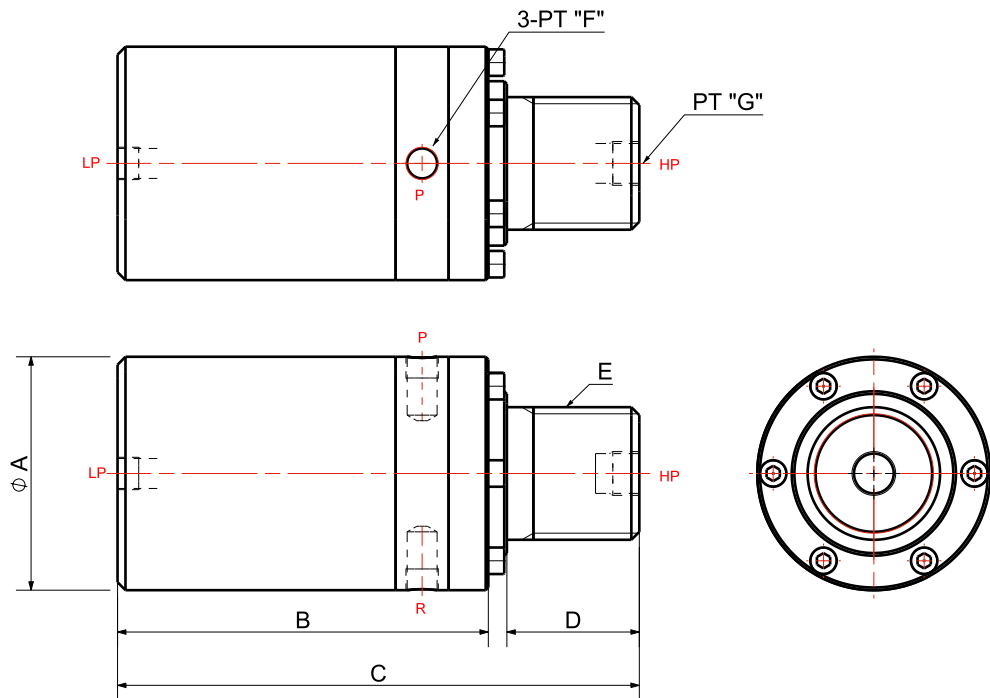

Hydraulic Intensifier

Intensifier circuit diagram by Sequence valve.

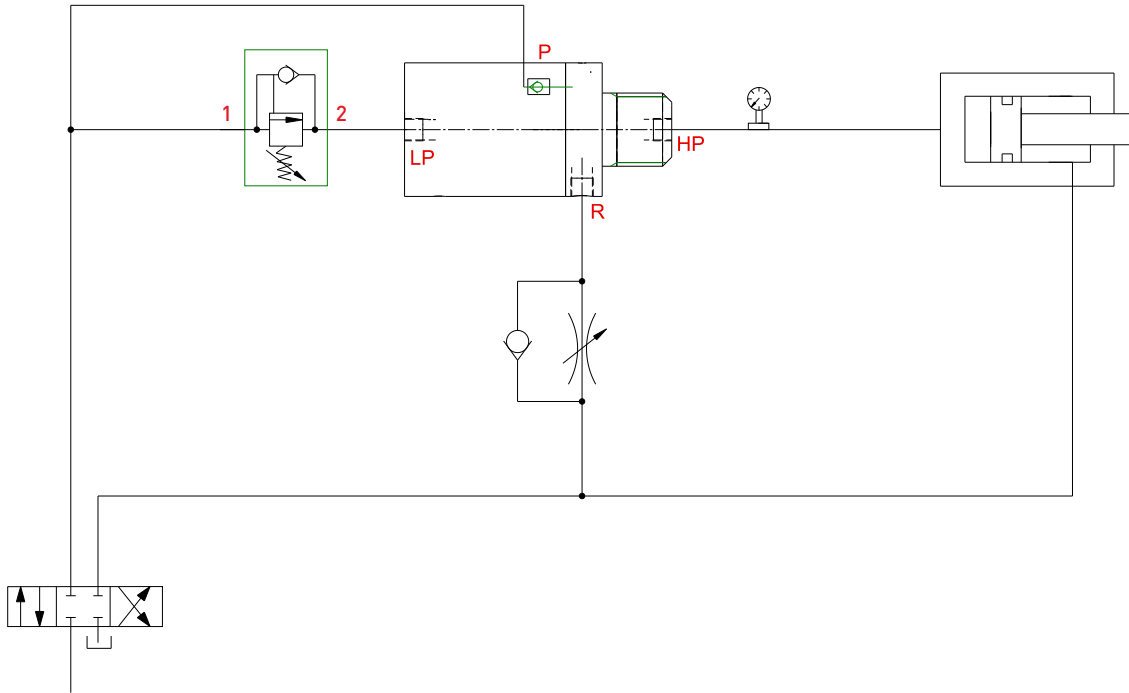

Intensifier circuit diagram by Sol valve.

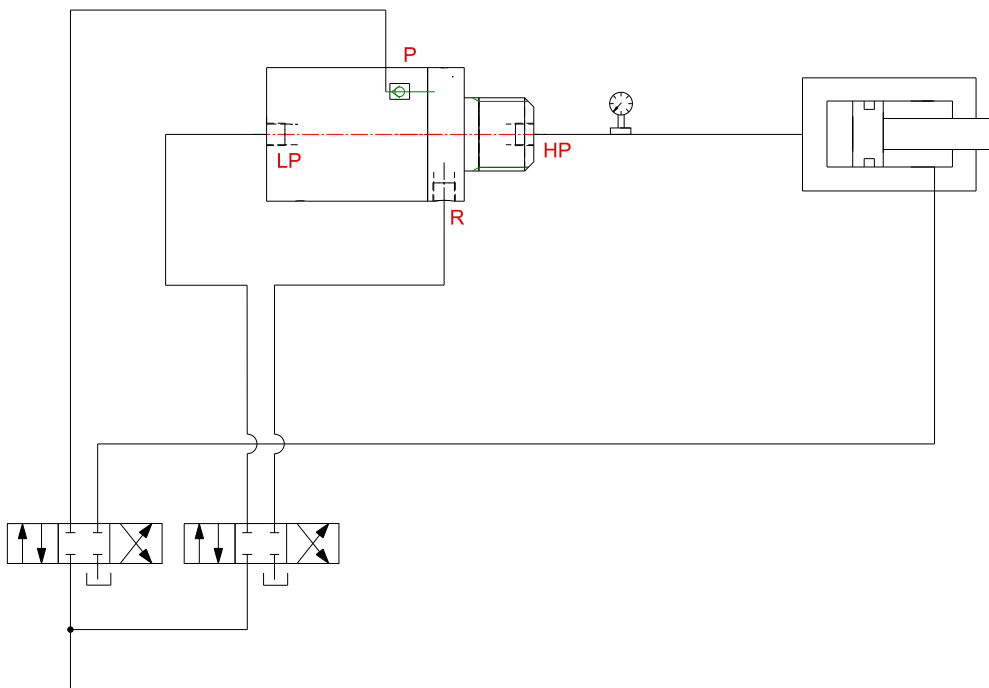



Standard Type



Gasket Type

Sequence Valve

Features

1. 2개 이상의 분기 회로 사이에 설치하여 회로안의 작동 순서를 압력에 의해 제어하는 밸브이다.
1. It is a valve that is installed between two or more branch circuits and controls the operation sequence in the circuit by pressure.

Specifications

- | | |
|--|--|
| 1. 작동압력 : | 1. Operating Pressure : |
| SQV-1414A/GA : 35~210kgf/cm ² | SQV-1414A/GA : 35~210kgf/cm ² |
| SQV-1414B/GB : 20~105kgf/cm ² | SQV-1414B/GB : 20~105kgf/cm ² |
| SQV-1414D/GD : 14~55kgf/cm ² | SQV-1414D/GD : 14~55kgf/cm ² |
| 2. 사용온도 : 0~60°C | 2. Operating Temperature : 0~60°C |

> Standard Type (SQV-1414A/B/D)

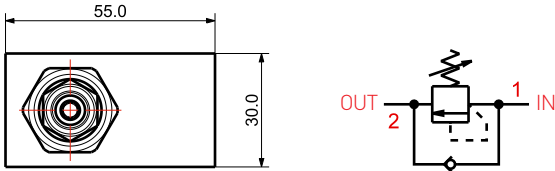

> Gasket Type (SQV-1414GA/GB/GD)

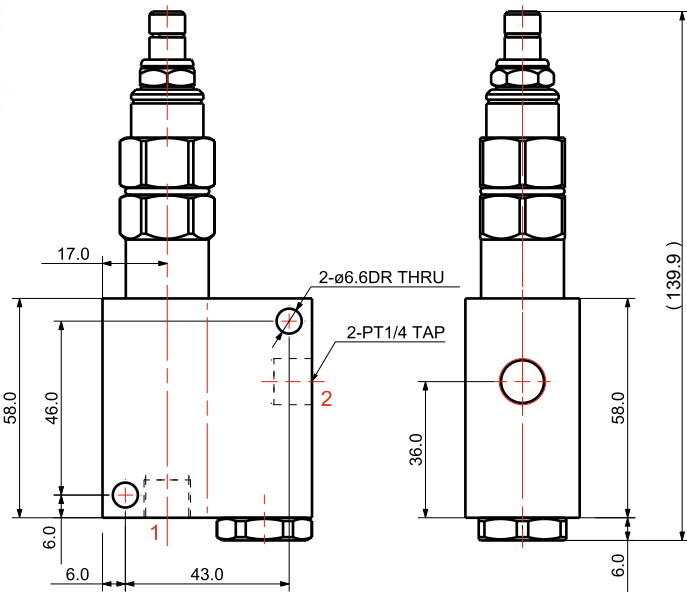
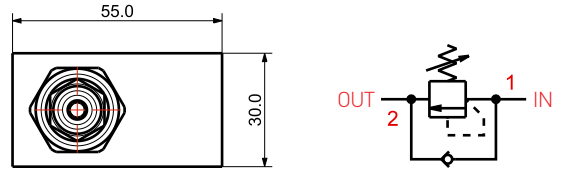

Weight : 0.86kg

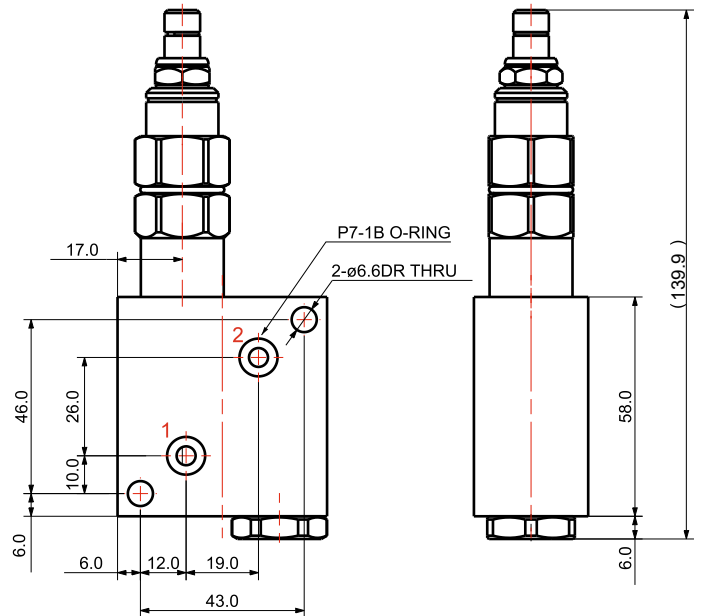

Weight : 0.89kg

Sequence Valve

Work Support, Sequence Valve를 조합해서 사용하는 회로
Circuit diagram using work support, and Sequence valve.

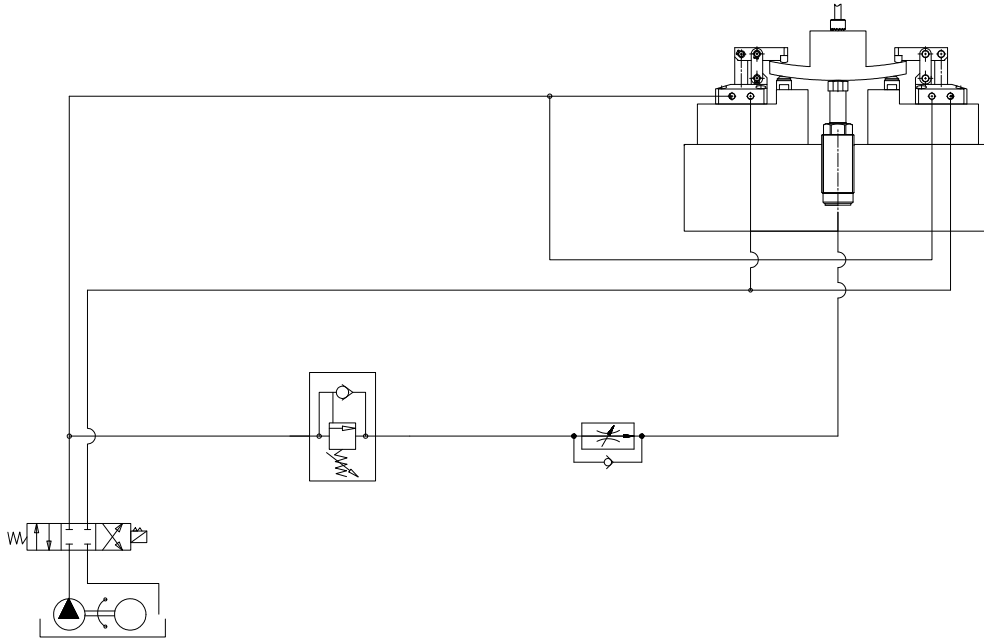

Flow Control Valve와 Sequence Valve의 구별법
Distinction of flow control valve and sequence valve.

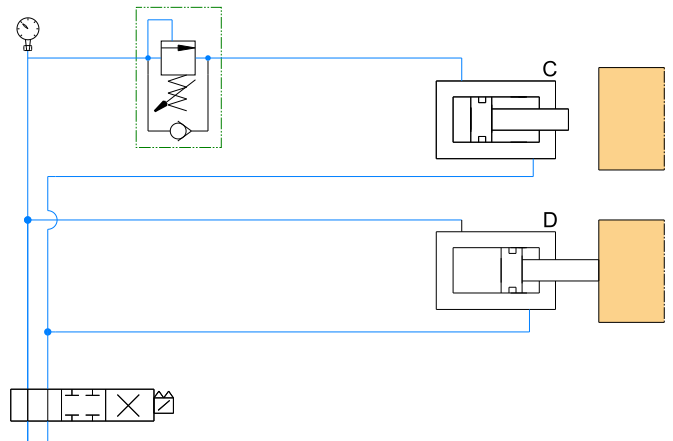
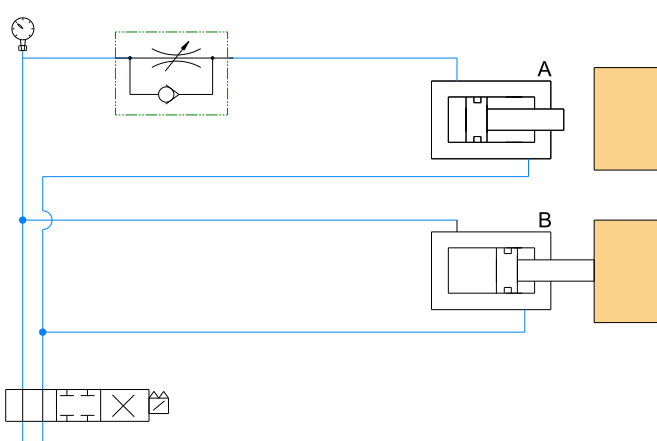

1. Flow Control Valve

실린더 B가 빠르게 움직이는 동안 실린더 A는 느리게 움직인다.
실린더 B가 공작물에 닿아 있어도 게이지에는 약 5kgf/cm²를 나타낸다.
즉, 회로의 압력 평형을 이루는 관계로 실린더 A가 도달 할때까지 실린더 B는 기다린다.

Cylinder A moves slowly during cylinder B moves fast.
Gage shows approx. 5kgf/cm² when cylinder B contact with workpiece.
In other words, cylinder B waits until cylinder A approaches due to equal pressure of circuit.

2. Sequence Valve

실린더 D가 빠르게 움직이는 동안 실린더 C에는 전혀 유압이 공급되지 않다가 Sequence valve의 설정압에 도달하면 유압이 공급되면서 실린더 C도 움직인다. 이때 이미 실린더 D는 상당한 클램프력을 발휘한다.

Cylinder C has no hydraulic pressure during cylinder D moves fast.
When set pressure of sequence valve is reached, cylinder C moves as hydraulic is provided. Cylinder D's clamping force is already very high.

Flow Control Valve Block Type

> SVB-0014G



> SVB-0018



Features

- | | |
|----------------------------------|--|
| 1. 유량 조절 밸브 | 1. Controlling hydraulic flow |
| 2. 컴팩트 사이즈 | 2. Compact size |
| 3. 사용압력: 0~70kgf/cm ² | 3. Operating Pressure: 0~70kgf/cm ² |

> SVB-0014G (Weight: 0.16kg)

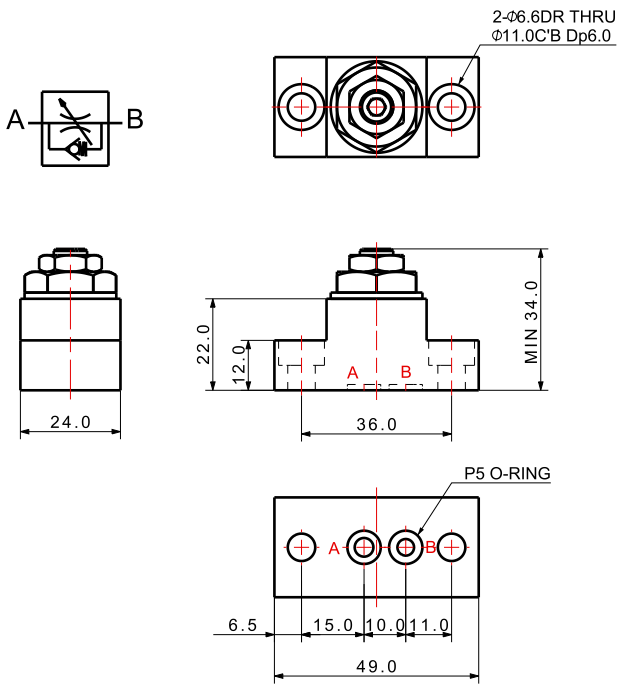

> SHB-0014G

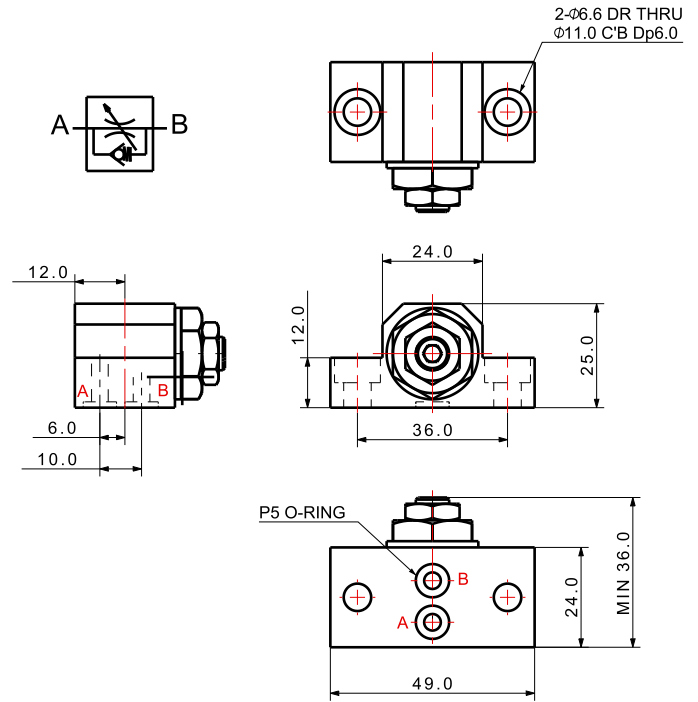

> SVB-0018

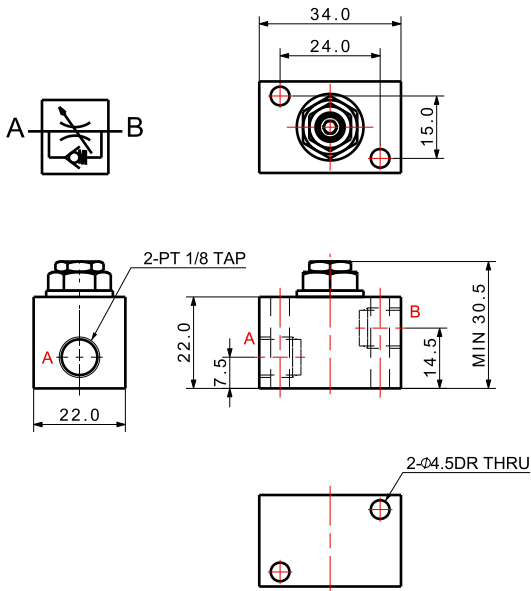

> SVB-0018G

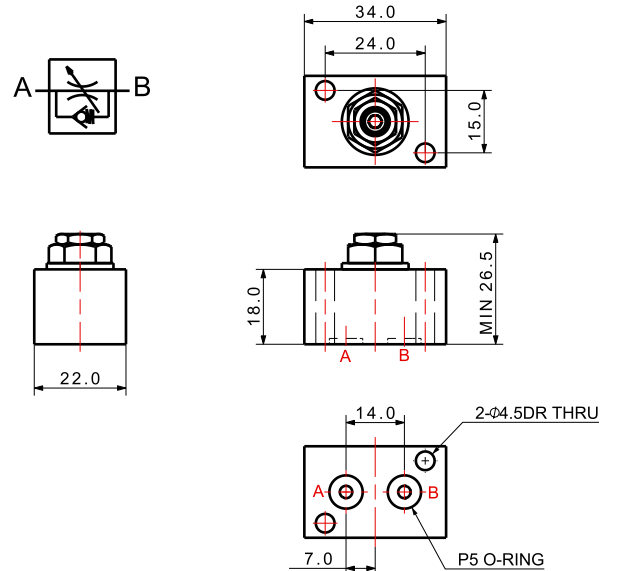



Direction Valve

Features

1. 작동상에 좁은 공간을 차지하므로 치공구에 다양하게 사용할 수 있다.
2. 비교적 간단한 구조로 되어 있어 가격이 저렴하다.

1. It occupies a small space in operation and can be used various ways in jig & fixture.
2. Simple structure and inexpensive.

Specifications

- | | |
|------------------------------------|--|
| 1. 사용압력 : 0~100kgf/cm ² | 1. Operating Pressure : 0~100kgf/cm ² |
| 2. Seal 재료 : 니트릴 고무 | 2. Seal Material : Nitrile rubber |
| 3. 무게 : 2.3kg | 3. Weight : 2.3kg |

> DCV - 30 40

① ②

① 3 Position ② 4 Ways

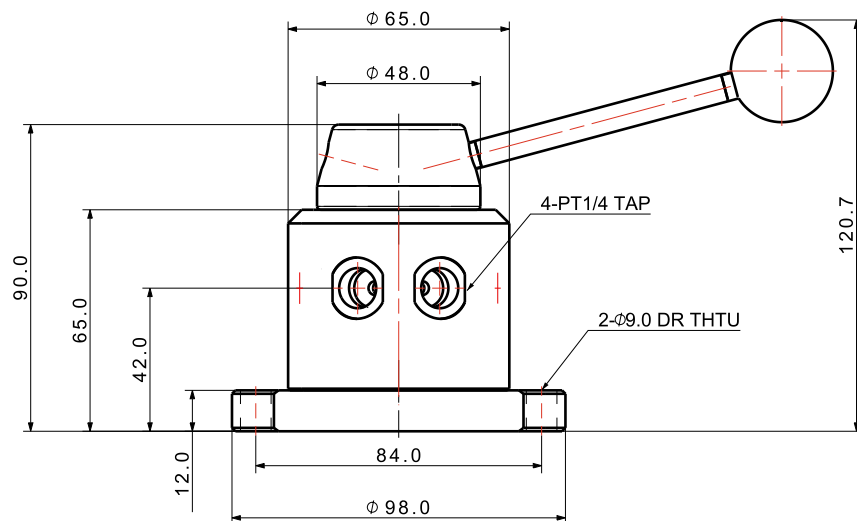
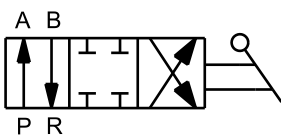
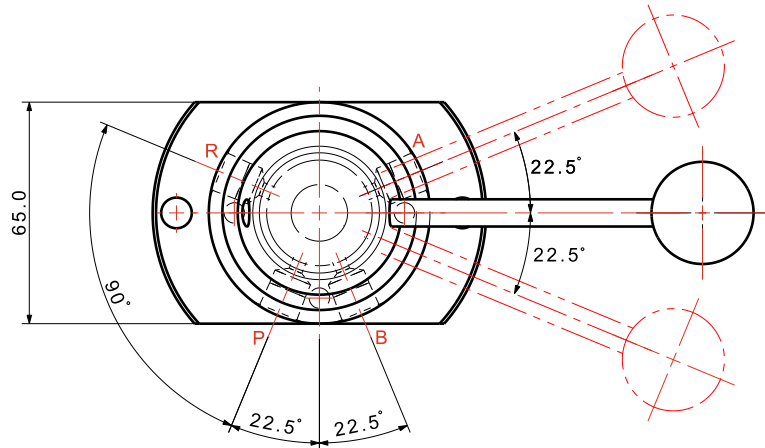



기타 제품들

Other Products



QR코드를 스캔하시면 작동영상을 보실 수 있습니다.
Please scan the QR code for watching operating animation.

Application

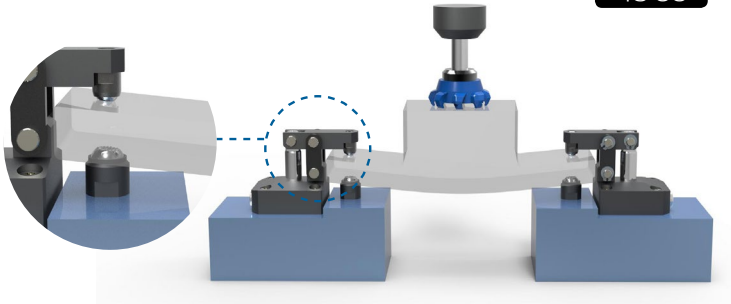

Swivel Pad

Features

- | | |
|--|--|
| <ol style="list-style-type: none"> 1. 평탄하지 않은 공작물 클램핑에 사용된다. 2. 클램핑으로 인한 소재의 변형을 해결할 수 있다. 3. 패드 볼은 9도로 움직인다. 4. 패드 볼 표면은 평면과 다이아몬드 형상 2종이 있다. 5. 클램핑력을 항상 시킨다. 6. 불규칙하게 변하는 클램핑 면에 적절하게 대응한다. | <ol style="list-style-type: none"> 1. It is used for clamping an uneven workpiece. 2. The deformation of the material caused by the clamping can be solved. 3. Pad ball moves in 9 degrees. 4. The pad ball surface provides two types - a flat and a diamond shape. 5. Improves the clamping force. 6. Corresponds to irregularly changing clamping surfaces. |
|--|--|

> SPF/D - 08 00
SPF/D - 08 25

① ②

① F=Flat, D=Diamond ② Screw size

Tap Type-Flat Pad



ø14: +0.023/+0.012
ø20: +0.028/+0.015
ø30: +0.028/+0.015

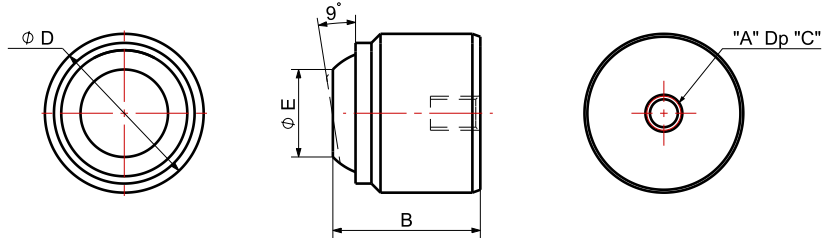

MODEL NO.	DIMENSIONS (mm)							
	A	B	C	øD	øE	Max Load Capacity	TYPE	Weight(g)
SPF-0313	M3	13	3	14	7.7	0.8ton	Flat	13
SPF-0419	M4	19	5	20	10.3	2.1ton	Flat	39
SPF-0527	M5	27	7	30	20.5	7.9ton	Flat	130

Tap Type-Diamond Pad



ø14: +0.023/+0.012
ø20: +0.028/+0.015
ø30: +0.028/+0.015

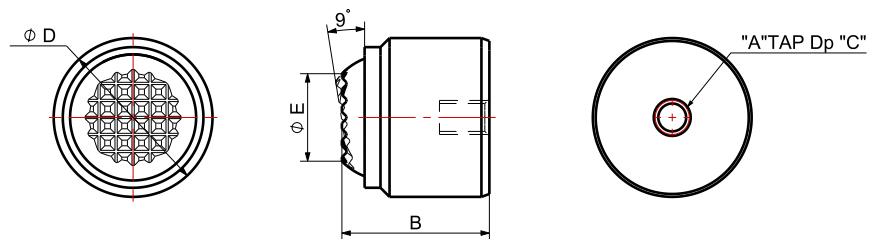

MODEL NO.	DIMENSIONS (mm)							
	A	B	C	øD	øE	Max Load Capacity	TYPE	Weight(g)
SPD-0313	M3	13	3	14	7.7	0.8ton	Diamond	13
SPD-0419	M4	19	5	20	10.3	2.1ton	Diamond	39
SPD-0527	M5	27	7	30	20.5	7.9ton	Diamond	130

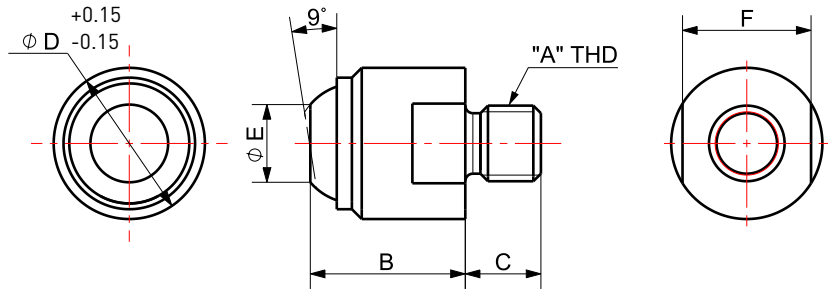

Bolt Type-Flat Pad



MODEL NO.	DIMENSIONS (mm)						Max Load Capacity	Type	Weight(g)
	A	B	C	ϕD	E	F			
SPF-0600	M6x1.0P	13	8	13	7.7	11	0.8ton	Flat	13
SPF-0800	M8x1.25P	12.5	8	14	7.7	11	0.8ton	Flat	15
SPF-0800-A	M8x1.25P	20.5	10	20	10.3	17	2.1ton	Flat	46
SPF-0815	M8x1.25P	12.5	15	14	7.7	11	0.8ton	Flat	18
SPF-0825	M8x1.25P	12.5	25	14	7.7	11	0.8ton	Flat	25
SPF-1000	M10x1.5P	20.5	10	20	10.3	17	2.1ton	Flat	48
SPF-1015	M10x1.5P	20.5	15	20	10.3	17	2.1ton	Flat	51
SPF-1030	M10x1.5P	20.5	30	20	10.3	17	2.1ton	Flat	62
SPF-1200	M12x1.75P	20.5	12	20	10.3	17	2.1ton	Flat	39
SPF-1235	M12x1.75P	20.5	35	20	10.3	17	2.1ton	Flat	73
SPF-1600	M16x2.0P	29.5	16	30	20.5	27	7.9ton	Flat	167
SPF-1640	M16x2.0P	29.5	40	30	20.5	27	7.9ton	Flat	216

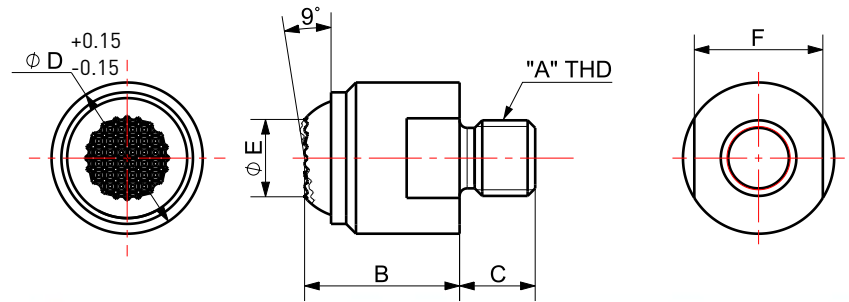

Bolt Type-Diamond Pad



MODEL NO.	DIMENSIONS (mm)						Max Load Capacity	Type	Weight(g)
	A	B	C	ϕD	E	F			
SPD-0600	M6x1.0P	13	8	13	7.7	11	0.8ton	Diamond	13
SPD-0800	M8x1.25P	12.5	8	14	7.7	11	0.8ton	Diamond	15
SPD-0800-A	M8x1.25P	20.5	10	20	10.3	17	2.1ton	Diamond	46
SPD-0815	M8x1.25P	12.5	15	14	7.7	11	0.8ton	Diamond	18
SPD-0825	M8x1.25P	12.5	25	14	7.7	11	0.8ton	Diamond	25
SPD-1000	M10x1.5P	20.5	10	20	10.3	17	2.1ton	Diamond	48
SPD-1015	M10x1.5P	20.5	15	20	10.3	17	2.1ton	Diamond	51
SPD-1030	M10x1.5P	20.5	30	20	10.3	17	2.1ton	Diamond	62
SPD-1200	M12x1.75P	20.5	12	20	10.3	17	2.1ton	Diamond	39
SPD-1235	M12x1.75P	20.5	35	20	10.3	17	2.1ton	Diamond	73
SPD-1600	M16x2.0P	29.5	16	30	20.5	27	7.9ton	Diamond	167
SPD-1640	M16x2.0P	29.5	40	30	20.5	27	7.9ton	Diamond	216

- > TCP - 12
- > TCP - 13
- > TCP - 42



- > TCP - 40
- > TCP - 21
- > TCP - 41



Tungsten Carbide Gripper Pad(초경패드)

Features

텅스텐 카바이드로 된 재질에 의해 일반 패드보다 클램프력이 30% 향상된다.

사용온도: ~700°C

The material made of tungsten carbide improves the clamping force by 30% compared to general pads.

Application

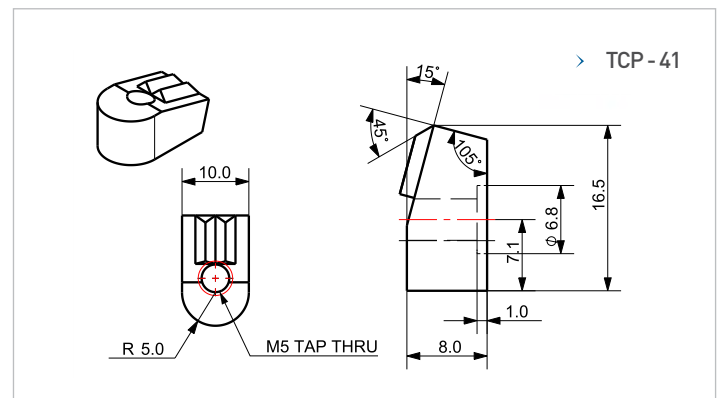
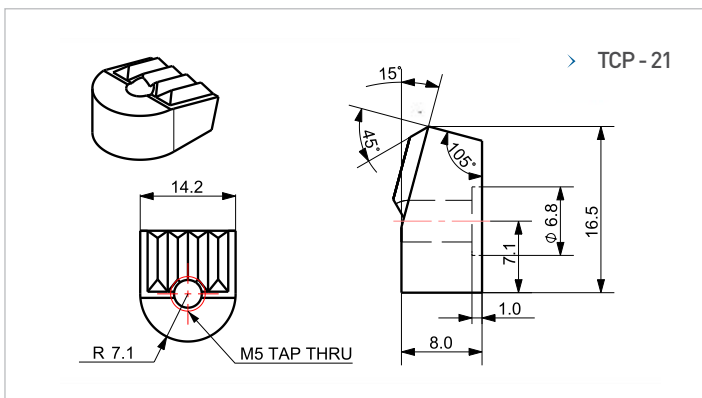
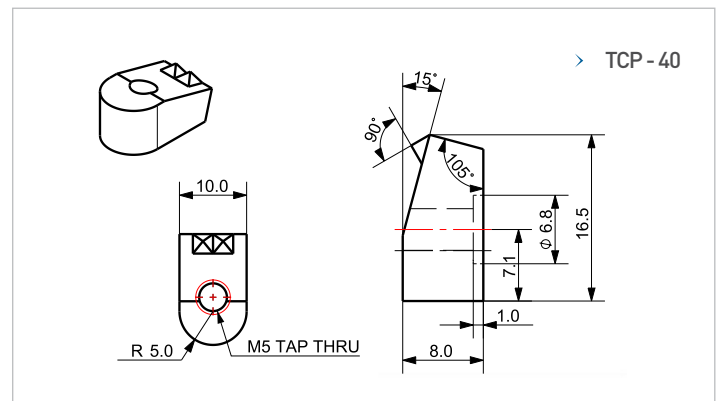
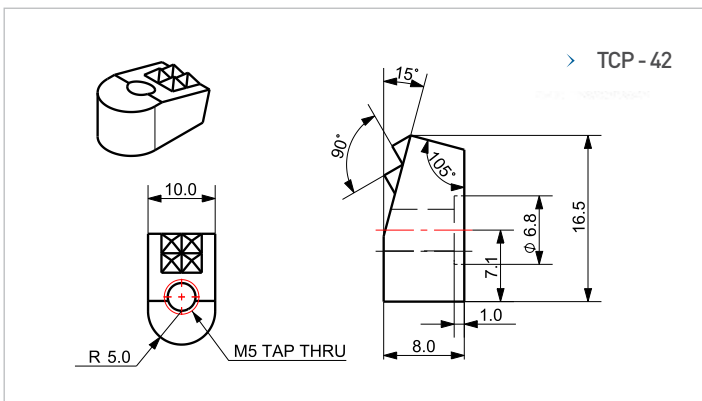
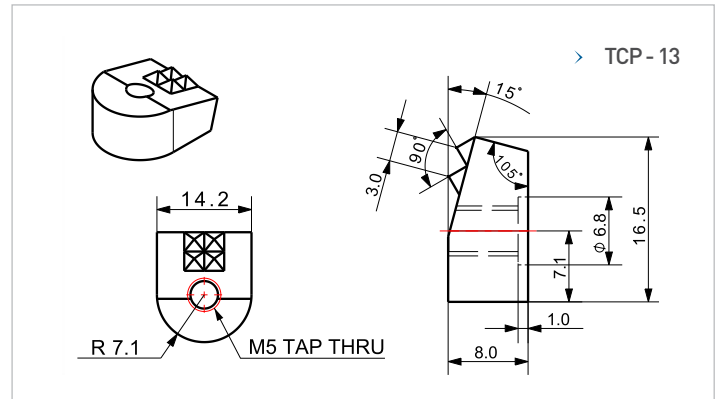
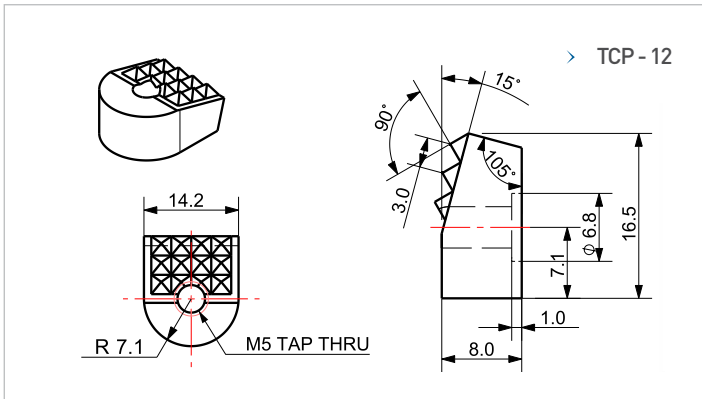
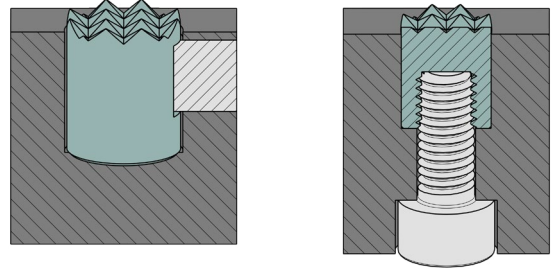

> TCP - 70



> TCP - 60



> TCP - 50



> TCP - 10



> TCP - 11



> TCP - 31



> TCP - 32



Tungsten Carbide Gripper Pad(초경패드)

Features

텅스텐 카바이드로 된 재질에 의해 일반 패드보다 클램프력이 30% 향상된다.

사용온도: ~700°C

The material made of tungsten carbide improves the clamping force by 30% compared to general pads.

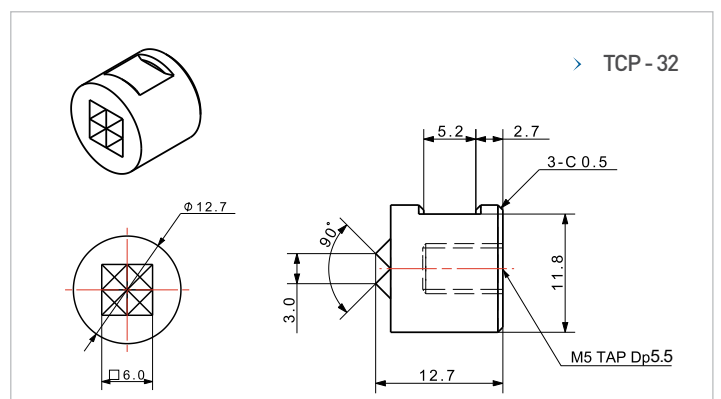
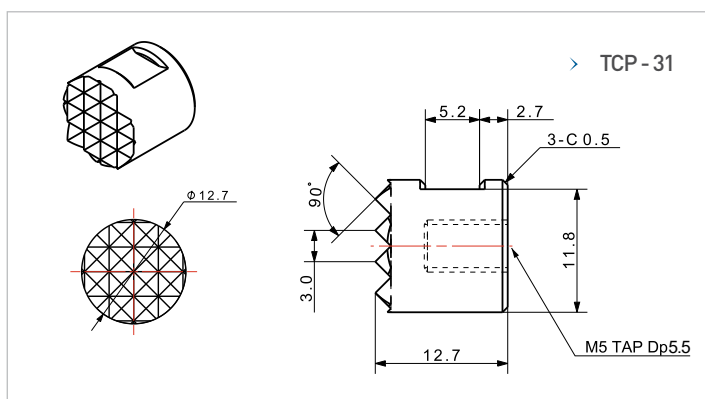
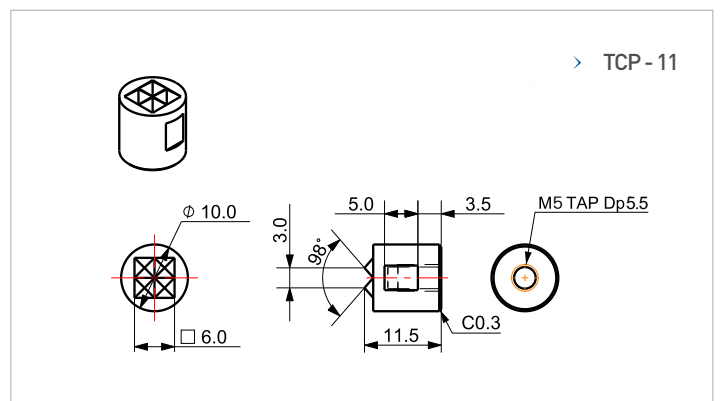
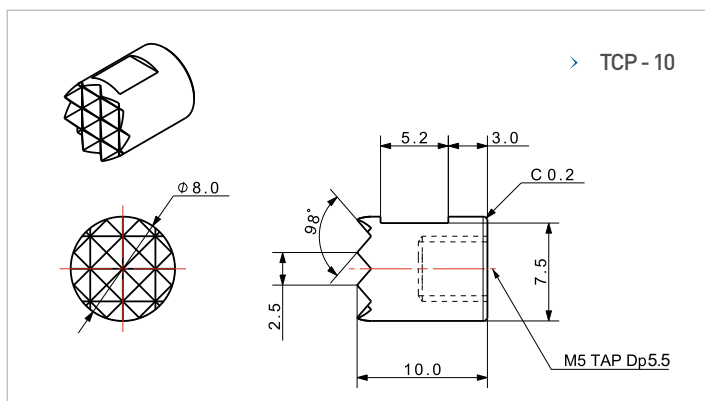
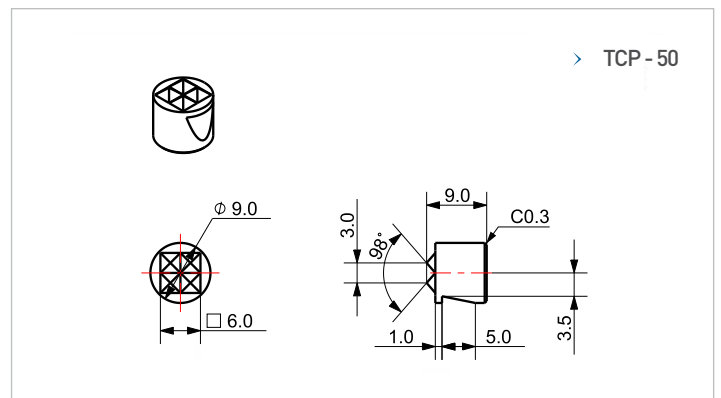
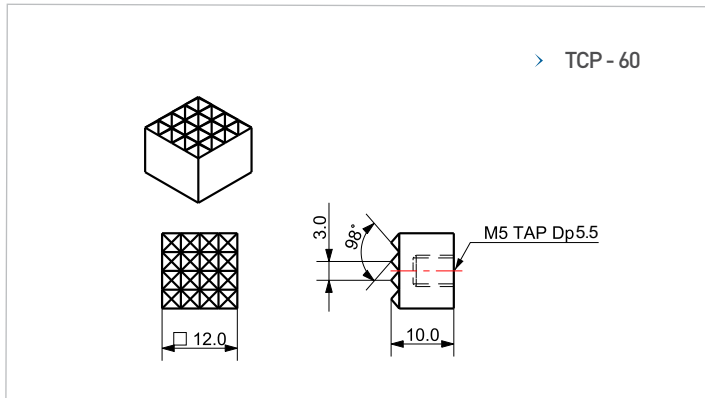
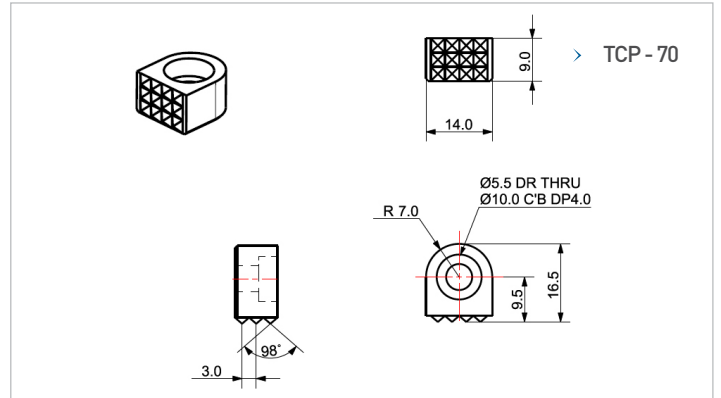

Mounting Base Accessories

> MBR/S - 20 10

① ② ③

① R=Round, S=Square ② Threaded Diameter ③ Thickness



Application

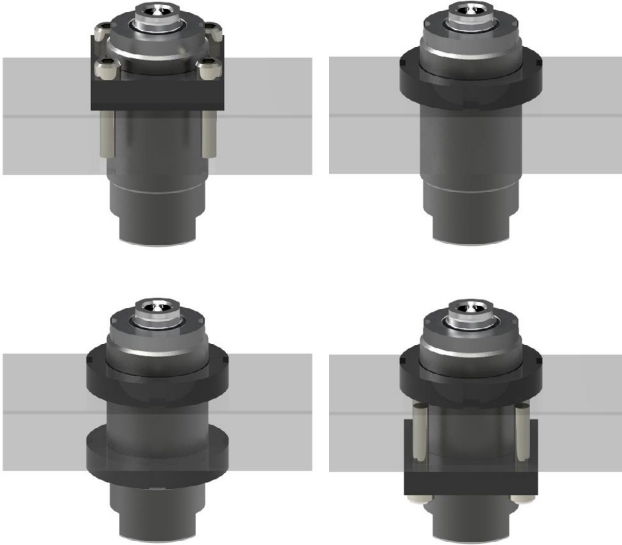

Dimensions

MODEL NO.	DIMENSIONS (mm)				
	φA	B	C	D	E
MBR-2010	32	10	4	M20 x P1.0	2.0
MBR-2110	32			M20 x P1.5	
MBR-2510	38		M25 x P1.5		
MBR-2810	40		M28 x P1.5		
MBR-3010	45		M30 x P1.5		
MBR-3210	45		M32 x P1.5		
MBR-3610	52		M36 x P1.5		
MBR-3810	52		M38 x P1.5		
MBR-4010	58		M40 x P1.5		
MBR-4510	65		11	6	
MBR-4811	70	M48 x P1.5			
MBR-5011	70	M50 x P1.5			
MBR-6011	80	7	M60 x P1.5	3.0	
MBR-6111	80				
MBR-6512	85	12	8	M65 x P2.0	3.5
MBR-7012	92				
MBR-8015	105	15	10	M80 x P2.0	4.0
MBR-9016	120				

> MBR - □□□□

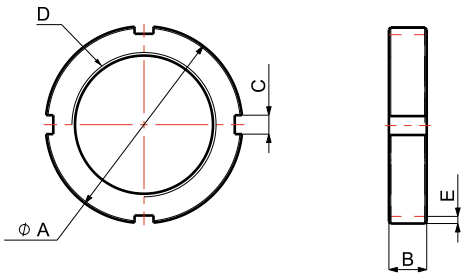

> MBS - □□□□

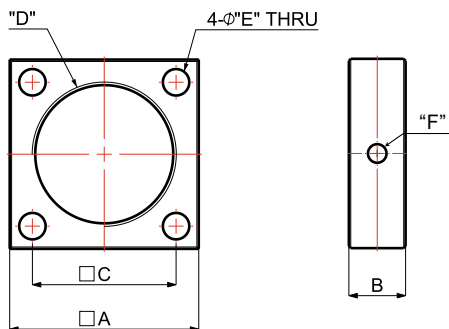

MODEL NO.	DIMENSIONS (mm)						
	A	B	C	D	E	F	
MBS-2012	30	12	22	M20 x P1.0	4.5	M6 x P1.0	
MBS-2112	30			M20 x P1.5			
MBS-2512	38		28	M25 x P1.5	5.5		
MBS-2812	40		29	M28 x P1.5	6.7		
MBS-3012	42		32	M30 x P1.5	7.0		
MBS-3212	42			M32 x P1.5			
MBS-3615	45		15	36	M36 x P1.5		9.0
MBS-3815	50			38	M38 x P1.5		
MBS-4012	50		25	40	M40 x P1.5		M8 x P1.25
MBS-4518	60			45	M45 x P1.5		
MBS-4820	60	48		M48 x P1.5			
MBS-5012	65	50		M50 x P1.5			
MBS-6015	75	60		M60 x P1.5	11.0		
MBS-6025	75			M60 x P1.5			
MBS-6125	75	65		M60 x P2.0	13.0		
MBS-6525	80			M65 x P2.0			
MBS-7025	90	70		M70 x P2.0	13.0		
MBS-8025	100			M80 x P2.0			
MBS-9025	110	90	M90 x P2.0				

Quick Action Clamp

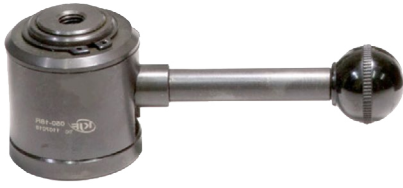

Application

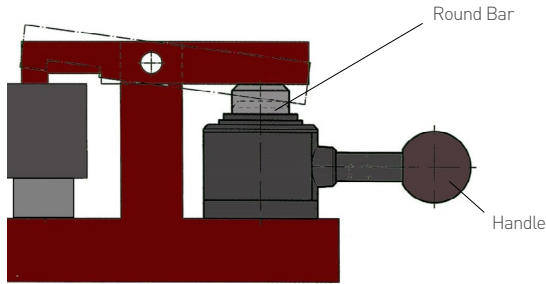

Features

1. 손잡이를 90도 회전시키면 Round Bar가 12mm 전진한다.
2. 회전구간 중 25도는 10mm만 전진한다.
3. 나머지 65도 구간에서 2mm가 전진한다(클램프구간).

1. If the handle rotates 90°, the round bar goes forward 12mm.
2. The round bar goes forward only 10mm in the 25° of rotating section.
3. It goes forward 2mm in the rest 65° rotating section (clamping section).

Specification

- | | |
|---------------------|---------------------------|
| 1. 스트로크: 12mm(10+2) | 1. Stroke: 12mm(10+2) |
| 2. 클램프력: 500kgf | 2. Clamping Force: 500kgf |
| 3. 중량: 900g | 3. Weight: 900g |
- > Model No. QAR-0512

> Model No. QAR-0512

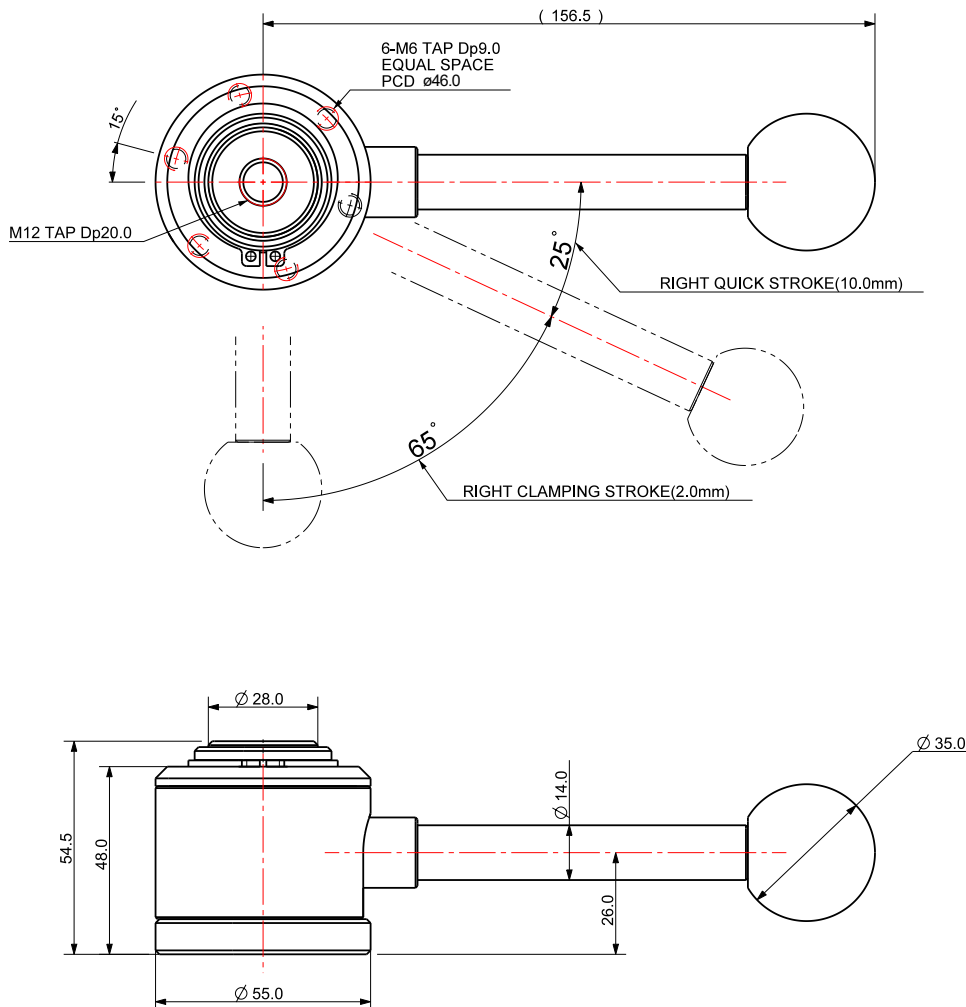

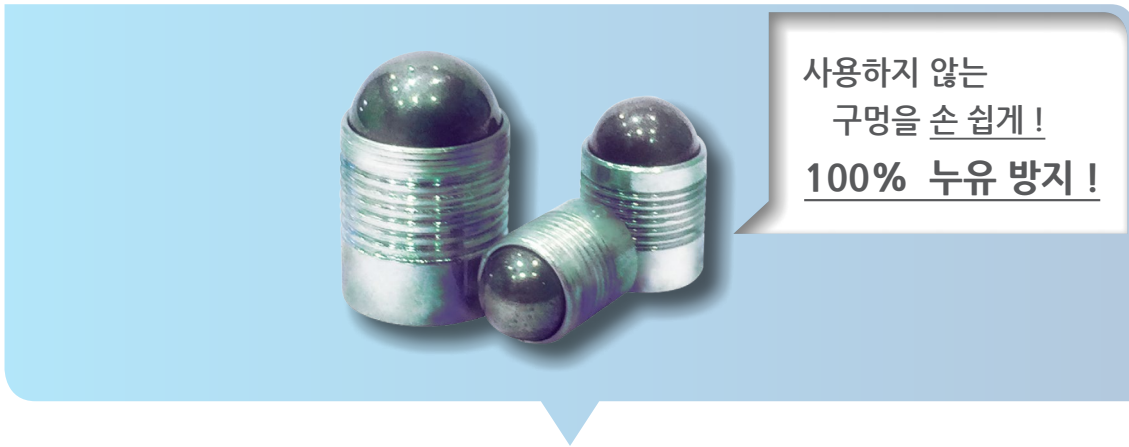

씰링플러그

SEALING PLUG/EXPANDER

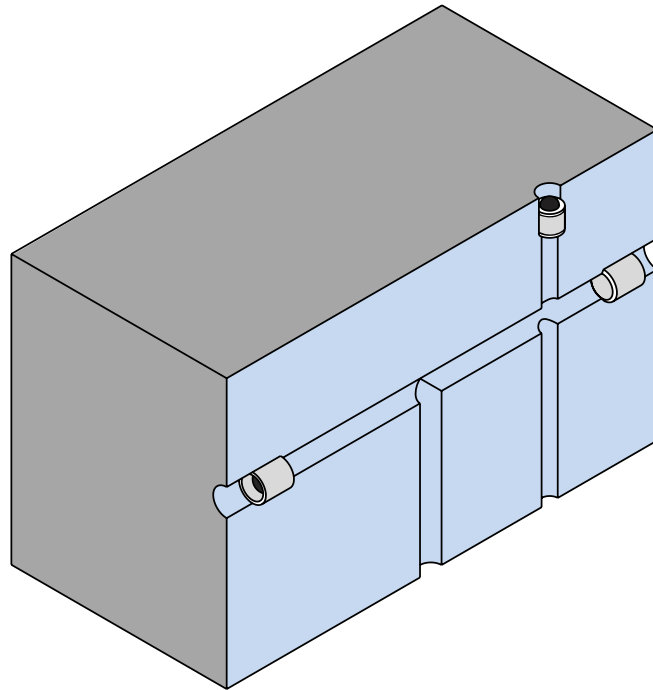

씰링플러그는 유압용품에서 사용하지 않는 구멍을 쉽게 막아주는 부품으로 지그와 픽스처, 자동차의 ABS부력, 중장비, 선박, 반도체 제품 생산기계에 주로 사용됩니다.

씰링플러그

SEALING PLUG/EXPANDER

- 1. 원가절감(작업공정 및 시간 단축)
- 2. Leakage 100% 방지

- 3. 규격 : 3mm~12mm
- 4. 슬리브: 표면처리강, 아연도금 (6가 크롬 불포함)
볼: 베어링강, 열처리

- 5. 사용정격압력 : 280~450kgf/cm²
사용최고압력 : 900~1400kgf/cm²
* 규격은 F 치수를 기준으로 선정.

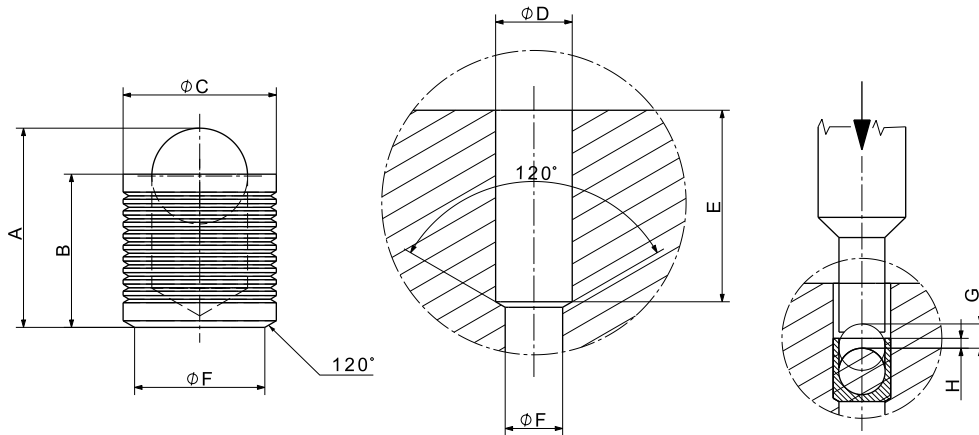

품번	규격	A	B	φC h9 mm	φD + 0.1	E 최소	φF 최대	G	H ± 0.2
KSP-300		4.6	3.6	3.0	3.0	3.4	2.2	1.2	0.4
KSP-400		5.2	4.0	4.0	4.0	3.8	3.3	1.5	0.2
KSP-500		7.0	5.5	5.0	5.0	5.3	4.3	2.0	0.4
KSP-600		8.6	6.5	6.0	6.0	6.3	5.3	2.5	0.4
KSP-700		10.1	7.5	7.0	7.0	7.3	6.4	3.0	0.4
KSP-800		11.7	8.5	8.0	8.0	8.3	7.4	4.0	0.3
KSP-900		13.7	10.0	9.0	9.0	9.8	8.4	4.0	0.4
KSP-1000		15.2	11.0	10.0	10.0	10.8	9.4	4.5	0.4
KSP-1200		18.0	13.0	12.0	12.0	12.8	10.6	5.5	0.4
KSP-1400		20.4	15.0	14.0	14.0	14.5	12.7	5.5	0.4

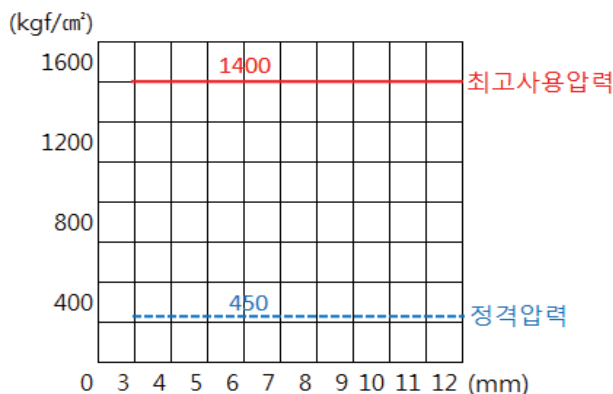

▶주의사항

1. 홀의 공차 D+0.1/-0(D : 씰링플러그 직경)
2. 홀표면 조도 : 8S~40S
3. 홀과 다른 홀과의 이격거리는 상하좌우 모두 사용할 씰링플러그의 직경 이상 이어야 함.
4. 펀치용 치구는 씰링플러그 볼에 대하여 수직으로 사용할 것.

▶기타

KSP 시리즈용 공구 : 씰링플러그 각 사이즈별로 펀치 공구가 준비되어 있습니다.

Customized Clamp

작업 환경에 따른 형상, 치수 및 사이즈 변경에 대한 주문제작이 가능합니다.

We provide customized shapes and sizes according to your work situation.

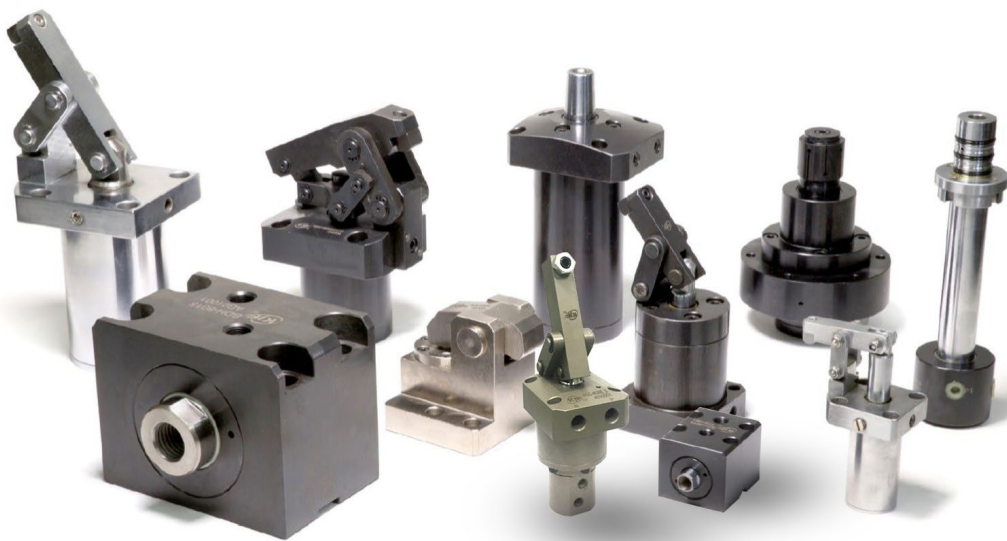

품질보증 Warranty

보증기간

Warranty period

보증기간은 당사공장 출하 후 1년6개월 또는 사용개시 후 1년 중에서 가까운 쪽을 선택합니다.

The warranty period is 18 months after shipment from the factory or 12 months from the start of use, whichever is earlier.

보증범위

다음 항목에 해당하는 경우는 보증대상에서 제외합니다.

1. 정해진 보수, 점검을 하지 않아서 생긴 고장
2. 사용자가 잘못 사용해서 고장이 생긴 경우
3. 고장의 원인이 당사에 기인하지 않은 경우
4. 기타 천재지변에 의해 발생한 고장
5. 소모성 부품 및 부품 교체 비용
6. 제품의 고장에 의하여 유발되는 손해 발생

Warranty range

The following items are not covered under warranty.

1. Malfunction caused by failure to perform maintenance or inspection.
2. Malfunction due to misuse of the user.
3. If the cause of the malfunction is not attributable to the company.
4. Failure caused by other natural disasters.
5. Replacement of consumable parts and costs.
6. Damage caused by product failure.

사용자들

Users



Toggle Clamps

- 토글 클램프 제품들도 구매 가능합니다.
- Toggle Clamps are available to be purchased.



Vertical Type



Horizontal Type



Push / Pull Type



Latch Type



Heavy Duty Weldable Type



Air Type

5th AXIS[®]

Workholding Evolved.

(주)케이제이에프는 미국 5th AXIS사의 독점대리점입니다.



5축바이스 / 콕체인지베이스 시스템



5축바이스 / 도보테일커터 방식

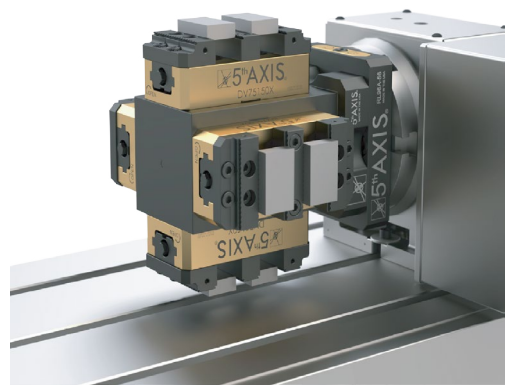

더블스테이션바이스 / 톰스톤베이스

Memo



